

INSTRUCTION BOOK
FOR
OPERATION AND MAINTENANCE
OF
RADIO TRANSMITTER BC-375-E
AND
ASSOCIATED EQUIPMENT

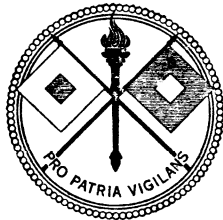

RESTRICTED

PUBLISHED BY AUTHORITY
OF
THE CHIEF SIGNAL OFFICER

FOR AIRPLANE TYPE _____

AAF SERIAL NO. _____

JANUARY 5, 1943

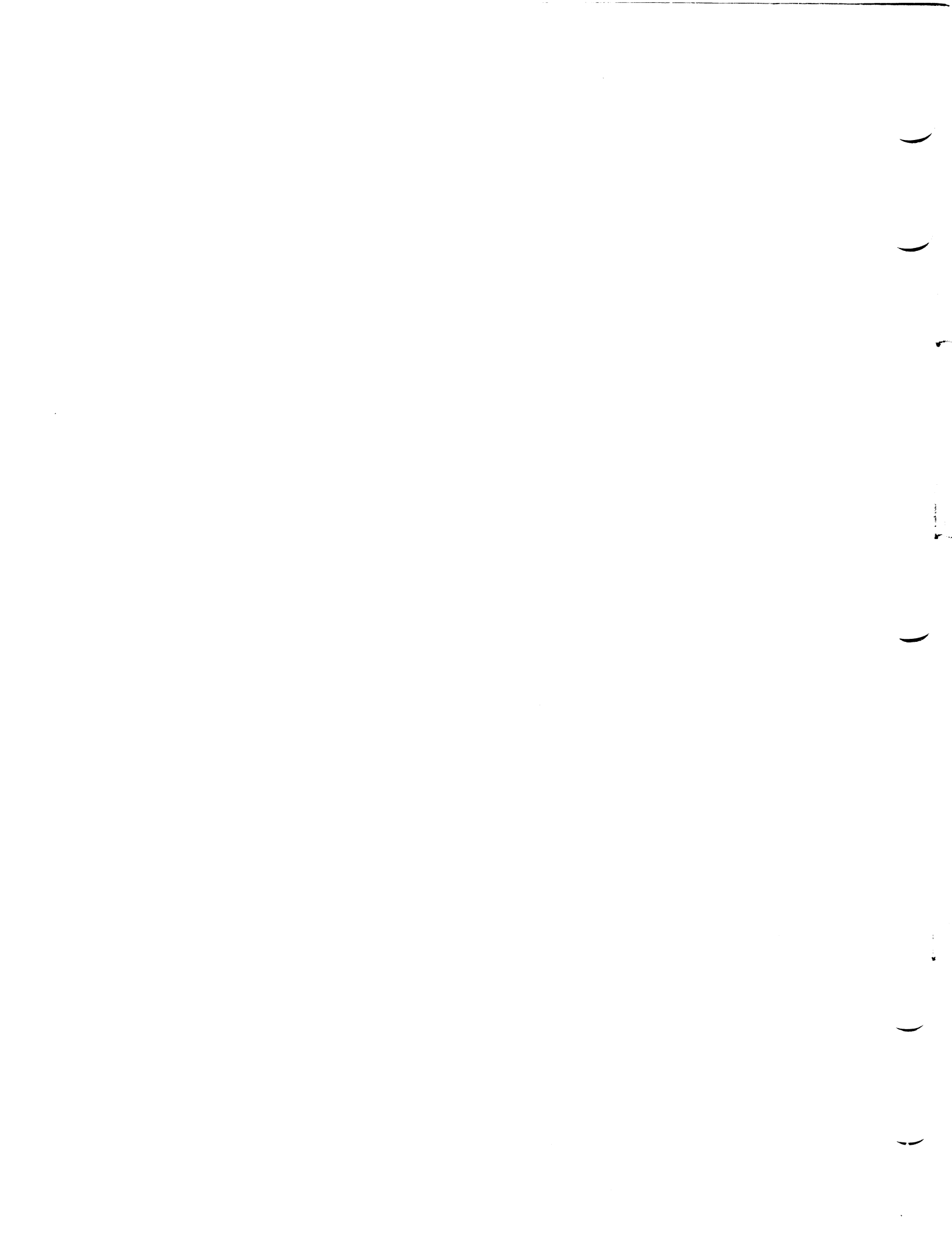

INSTRUCTION BOOK
FOR
OPERATION AND MAINTENANCE
OF
RADIO TRANSMITTER BC-375-E
AND
ASSOCIATED EQUIPMENT

RESTRICTED

Notice:—This document contains information affecting the national defense of the United States within the meaning of the Espionage Act (U.S.C. 50:31, 32). The transmission of this document or the revelation of its contents in any manner to any unauthorized person is prohibited.

The information contained in documents marked "RESTRICTED" will not be communicated to the public or to the press, but it may be communicated to any person known to be in the service of the United States and to persons of undoubted loyalty and discretion who are co-operating in governmental work. (AR-380-5).

PUBLISHED BY AUTHORITY
OF
THE CHIEF SIGNAL OFFICER

GEI-16282A

January 5, 1943

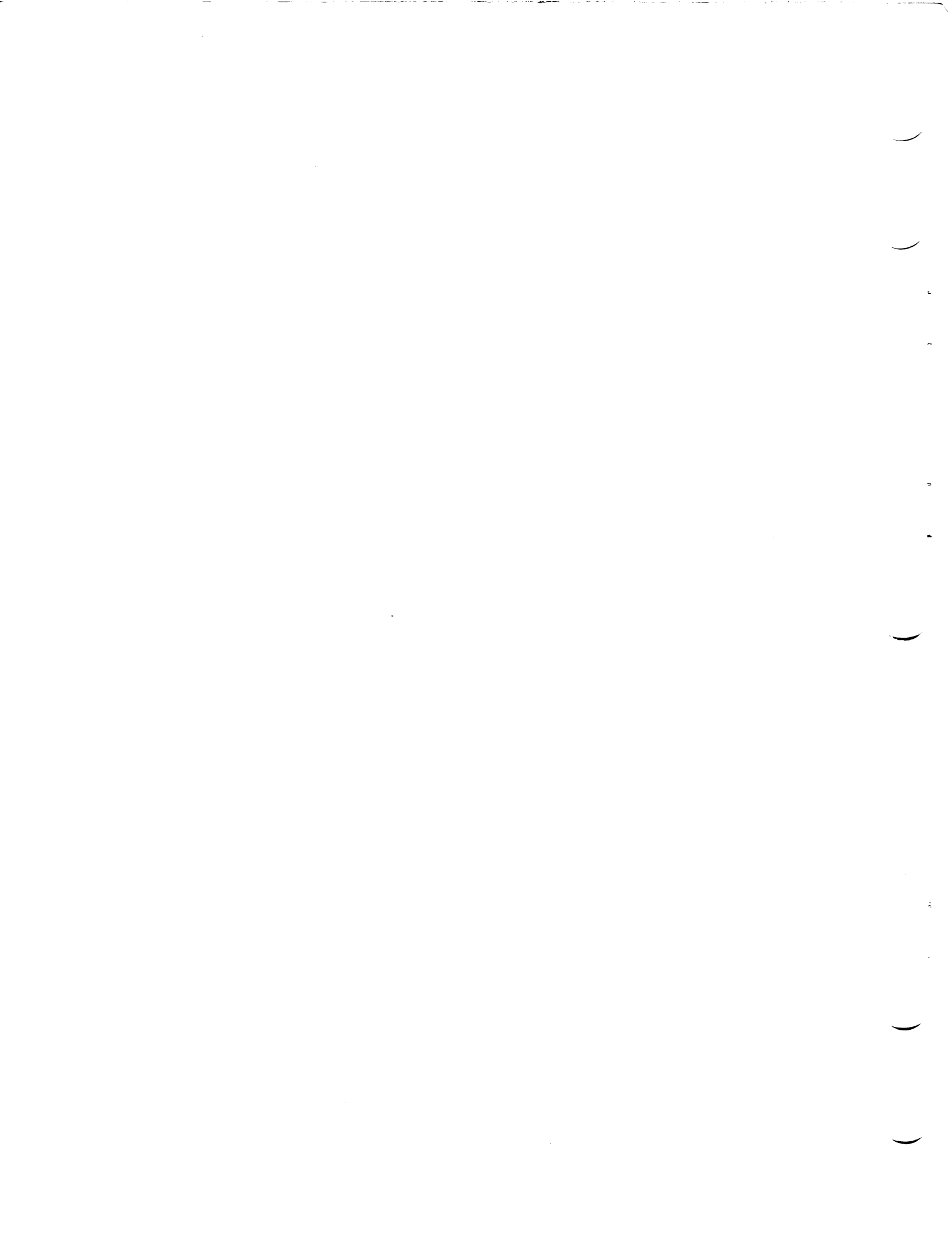

SAFETY TO HUMAN LIFE

OPERATION OF THIS EQUIPMENT INVOLVES THE USE OF HIGH VOLTAGES WHICH ARE DANGEROUS TO LIFE. OPERATING PERSONNEL MUST AT ALL TIMES OBSERVE ALL SAFETY REGULATIONS. DO NOT CHANGE TUBES OR MAKE ADJUSTMENTS INSIDE EQUIPMENT WITH HIGH-VOLTAGE SUPPLY ON. DO NOT COMPLETE OR MAINTAIN ANY CONNECTION BETWEEN RADIO TRANSMITTER AND DYNAMOTOR UNIT UNLESS ALL SHIELDS ON THE RADIO TRANSMITTER ARE IN PLACE.

KEEP AWAY FROM LIVE CIRCUITS

1. Under no circumstances should any person be permitted to operate the dynamotor unit with relay-fuse box cover or end bells removed; or to replace fuses with power on; or to remove, place, or handle removed plugs with the dynamotor unit running.
2. Under no circumstances adjust circuits or service the equipment when only the carrier is keyed off. The radio transmitter uses a grid-bias keying circuit, which does not remove high voltage when the key is open.

**DO NOT OPERATE THE EQUIPMENT
WITH SHIELDS REMOVED.**

FIRST AID

PERSONNEL ENGAGED IN THE INSTALLATION, OPERATION AND MAINTENANCE OF THIS EQUIPMENT OR SIMILAR EQUIPMENT ARE URGED TO BECOME FAMILIAR WITH THE FOLLOWING RULES, BOTH IN THEORY AND IN THE PRACTICAL APPLICATION THEREOF. IT IS THE DUTY OF EVERY RADIOMAN TO BE PREPARED TO GIVE ADEQUATE FIRST AID AND THEREBY PREVENT AVOIDABLE LOSS OF LIFE. YOUR OWN LIFE MAY DEPEND ON THIS.

Do These Three Things First in Any Emergency Requiring First Aid

1. Send for a doctor or carry the victim to a doctor.
2. Keep victim warm and quiet and flat on his back.
3. If breathing has stopped, apply artificial respiration. Stop all serious bleeding.

When, from any cause whatever, breathing has stopped, apply artificial respiration immediately and continue WITHOUT STOPPING until normal

breathing returns, or a doctor pronounces the victim dead. SPEED IN BEGINNING ARTIFICIAL RESPIRATION IS ESSENTIAL.

The Prone Pressure Method of Artificial Respiration

If Due to Electric Shock

1. PROTECT YOURSELF with DRY insulating material.
2. BREAK THE CIRCUIT by opening the power switch or pulling the victim free of the live conductor. DON'T TOUCH THE VICTIM WITH YOUR BARE HANDS UNTIL THE CIRCUIT IS BROKEN.
3. SPREAD DRY BLANKET ON THE GROUND, and roll victim to center of blanket with his arms extended over his head, so that he lies FACE DOWN on blanket.
4. BEND ONE OF THE VICTIM'S ARMS at

the elbow and rest victim's cheek on the back of his hand.

5. REMOVE FALSE TEETH, gum, candy, tobacco, food, etc. from victim's mouth.
6. LOOSEN ALL TIGHT CLOTHING, as belts or collars.
7. COVER VICTIM LOOSELY by wrapping the ends of the blanket around him.
8. STRADDLE VICTIM across thighs.
9. PLACE THE PALMS OF YOUR HANDS ON VICTIM'S BACK so that the little fingers of each hand just touch the victim's lowest ribs.

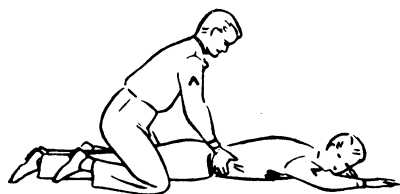

- (1) Straddle victim across thighs. Place the palms of your hands on the victim's back so that the little fingers of each hand just touch the victim's lowest ribs.

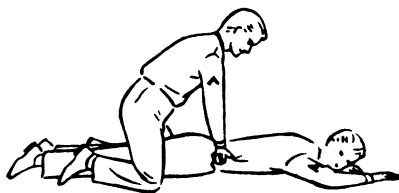

- (2) Keep your arms stiff and straight and swing your body forward, allowing your weight to bear down on victim. DO NOT PUSH OR USE FORCE.

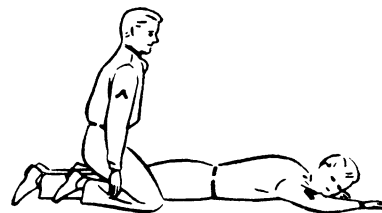

- (3) Swing back at once to relieve pressure, and then continue the rhythmic application of alternate pressure and release.

Blanket is not shown in above drawings for the sake of clarity.

10. **KEEP YOUR ARMS STIFF AND STRAIGHT** and swing your body forward, allowing your weight to bear down on the victim.
11. **DO NOT PUSH OR USE FORCE.**
12. **SWING BACK AT ONCE TO RELIEVE PRESSURE.**
13. **REPEAT** Number 10.
14. **REPEAT** Number 12.
15. **CONTINUE** as above, maintaining a steady rhythm until victim regains consciousness or is pronounced dead by a doctor.
16. **CONTINUE ARTIFICIAL RESPIRATION** even after victim begins to breathe, and until he becomes conscious.
17. **IF BREATHING STOPS AGAIN,** continue artificial respiration at once.
18. **DO NOT GIVE UP HOPE** of reviving the victim. Four hours or more of continuous application of artificial respiration may be required before consciousness returns.
19. **NEVER TRY TO FORCE LIQUIDS** down an unconscious person's throat. He will drown.
20. **ALWAYS WAIT UNTIL CONSCIOUSNESS RETURNS** before administering liquid stimulants.
21. **RECOMMENDED STIMULANTS ARE:** Hot, black coffee. Strong, hot tea. Aromatic spirits of ammonia, one teaspoonful to a glass of water.
22. **GIVE ONLY ONE STIMULANT,** which should be sipped slowly.
23. **ALCOHOLIC DRINKS** are not recommended, unless absolutely nothing else is available.
24. **WHEN VICTIM HAS RETURNED TO CONSCIOUSNESS,** allow him to lie quietly where he is for at least one hour, taking care that he is well covered and free from worry.
25. **IF POSSIBLE, CARRY, OR HAVE HIM CARRIED TO A DOCTOR.**

WOUNDS

Neglected wounds can have serious consequences. Any break in the skin is a wound. Paint small cuts and scratches immediately with **TINCTURE OF IODINE**. Deep cuts and wounds should be **KEPT CLEAN** but **DO NOT** use Tincture of Iodine on them. Washing **AROUND** and **AWAY FROM** the wound with ordinary soap and water, if no other antiseptic is available, is recommended. Other antiseptics for use on deep wounds are: Violet gentian, Potassium permanganate, Tincture of Merthiolate, or ordinary baking soda and water. Cover the wound with a sterile gauze dressing and hold in place with adhesive tape or a strip of gauze.

In cases of serious bleeding, when an artery has been cut, firm pressure is necessary to stop the flow of blood. Arterial bleeding is **BRIGHT RED** and comes from the wound in **SPURTS**, with each beat of the heart. Bleeding from a vein is **DARK RED** and flows steadily. Pressure is not often needed for venous bleeding.

Pressure is applied **ABOVE** the wound, or between the **WOUND AND THE HEART**, to stop **ARTERIAL BLEEDING**. Pressure is applied **BELOW** the wound, or **AWAY FROM THE HEART** to stop **VENOUS BLEEDING**.

Pressure is best applied and maintained by means of a **TOURNIQUET**.

A **TOURNIQUET** is a strip of cloth, bandage, or other material, tied **ABOVE** the wound. Tie a simple, double knot in the cloth and place a strong

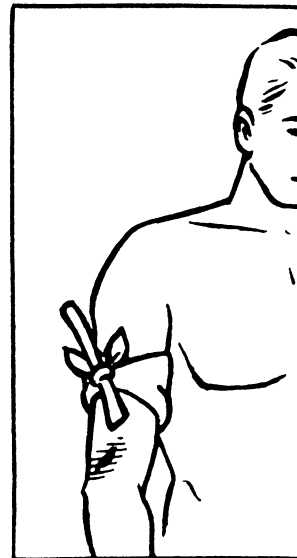

Tourniquet in position
ABOVE wound.

stick or other rigid member in the loop thus made, then tighten the knot by pulling the ends of the cloth.

With the rigid member thus held firmly in place, twist it, until the bleeding stops.

DO NOT maintain such pressure longer than 15 minutes at a time.

IF BLEEDING CONTINUES after loosening tourniquet, allow the blood to flow for about 30 to 60 seconds and then re-apply pressure. Continue until bleeding stops.

AFTER BLEEDING HAS STOPPED, the wound should be carefully covered with a sterile dressing. DO NOT TOUCH WOUND OR DRESSING WITH DIRTY HANDS!

Keep the victim LYING FLAT ON HIS BACK, AND WELL COVERED. DO NOT LET HIM SEE HIS WOUND. Divert his thoughts from himself.

Obtain the services of a DOCTOR AS SOON AS POSSIBLE.

BURNS

Burns, whether caused by contact with high voltage electrical equipment, fire, or friction, require immediate attention.

1. Apply AT ONCE any one of the following:
 - a. Tannic acid jelly.
 - b. Butesin picrate.
 - c. Paste made with baking soda and water.
 - d. Very strong, cool tea.

2. Applications should be LIBERAL and the burned area covered with STERILE GAUZE.
3. If clothing sticks to the burned areas, DO NOT ATTEMPT TO REMOVE IT. Treat burn as above.
4. Keep the victim WELL COVERED and LYING FLAT ON HIS BACK. Soothe and reassure him.
5. Obtain the services of a DOCTOR AS SOON AS POSSIBLE.



Always obtain the services of a doctor as quickly as possible.

Destruction of Abandoned Materiel in the Combat Zone

In case it should become necessary to prevent the capture of this
equipment and when ordered to do so,

**DESTROY IT SO THAT NO PART OF IT CAN BE SALVAGED, RECOGNIZED
OR USED BY THE ENEMY. BURN ALL PAPERS AND BOOKS.**

Means:

1. Explosives, when provided.
2. Hammers, axes, sledges or whatever heavy object is readily available.
3. Burning by means of incendiaries such as gasoline, oil, paper or wood.
4. Grenades and shots from available arms.
5. Where possible, and when time permits, bury all debris or dispose of it in streams or other bodies of water.

Procedure:

1. Obliterate all identifying marks. Destroy nameplates and circuit labels.
2. Demolish all panels, castings, switch- and instrument-boards.
3. Destroy all controls, switches, relays, connections and meters.
4. Rip out all wiring in electrical equipment. Smash gas, oil and water cooling systems in gas-engine generators, etc.
5. Smash every electrical or mechanical part whether rotating, moving or fixed.
6. Break up all operating instruments such as keys, phones, microphones, etc.
7. Destroy all classes of carrying cases, straps, containers, etc.

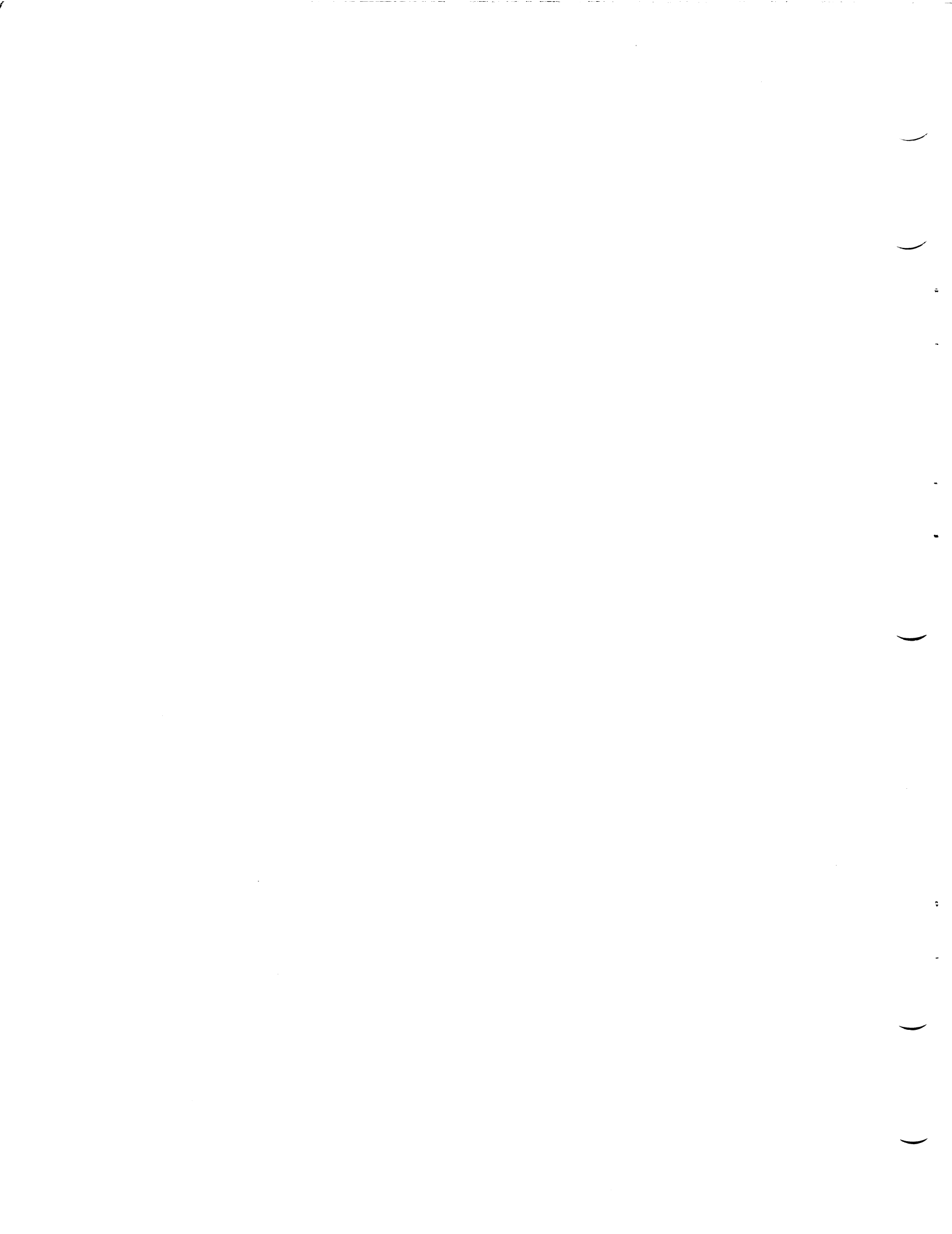

REPORT OF MAJOR FAILURE

In the event of major failure of any of the component units of this equipment, a report shall be submitted in the form indicated below. Copies of this report shall be forwarded to the Chief of Signal Section, Air Service Command, Patterson Field, Fairfield, Ohio, and to the Director, Signal Corps Aircraft Signal Service, Wright Field, Ohio.

1. Contract or order number.
2. Organization and station.
3. Nomenclature of equipment.
4. Nomenclature of component unit.
5. Date and nature of failure.
6. Type of airplane in which installed.
7. Recommendations.

)

)

)

)

)

TABLE OF CONTENTS

Page

SECTION I—DESCRIPTION

1. GENERAL.....	1
2. ANTENNA TUNING UNIT BC-306-A.....	1
3. CASE CS-48.....	1
4. DYNAMOTOR UNIT PE-73-C.....	2
5. RADIO TRANSMITTER BC-375-E.....	3
6. TRANSMITTER TUNING UNITS TU-5-B, ETC.....	4
7. CO-ORDINATION OF UNITS.....	4
8. AIRCRAFT RADIO SETS.....	4
9. LIST OF MAIN UNITS.....	5

SECTION II—EMPLOYMENT

10. INSTALLATION.....	6
a. Radio Transmitter BC-375-E.....	6
b. Dynamotor Unit PE-73-C.....	6
c. Cords.....	6
d. Antennas.....	6
e. Antenna Tuning Unit BC-306-A.....	7
f. Reel RL-30-B and Connector Clamp MC-163.....	7
g. Interconnection with Radio Receiver in Aircraft.....	8
11. PREPARATION FOR USE.....	8
a. Radio Transmitter BC-375-E.....	8
b. Dynamotor Unit PE-73-C.....	9
12. OPERATION.....	10
a. At High Altitudes.....	10
b. Transmitter Adjustment.....	10
c. Antenna Circuits.....	12
d. Dynamotor Unit PE-73-C.....	14
e. Reel RL-30-B.....	14
f. Operating Routine.....	15
13. SUMMARY COVERING NORMAL OPERATION.....	15

SECTION III—FUNCTIONING OF PARTS

14. RADIO TRANSMITTER BC-375-E.....	17
15. VACUUM TUBES.....	22
16. TRANSMITTER TUNING UNITS.....	23
17. ANTENNA TUNING UNIT BC-306-A.....	23
18. DYNAMOTOR UNIT PE-73-C.....	24

SECTION IV—MAINTENANCE

19. INSPECTION.....	25
20. LUBRICATION.....	26
21. SERVICE NOTES.....	27

SECTION V—SUPPLEMENTARY DATA

22. TABLE OF REPLACEABLE PARTS.....	35
23. TABLE OF INTERCHANGEABLE PARTS.....	50
24. RENEWAL PARTS.....	51
25. LIST OF MANUFACTURERS.....	54

LIST OF ILLUSTRATIONS

Figure		Page
1	Radio Transmitter BC-375-E and Associated Equipment.....	xx
2	Antenna Tuning Unit BC-306-A.....	1
3	Case CS-48.....	2
4	Dynamotor Unit PE-73-C.....	2
5	Radio Transmitter BC-375-E, Transmitter Tuning Unit TU-5-B in Place.....	3
6	Typical Front View of a Transmitter Tuning Unit without a Band Change Switch.....	4
7	Mounting FT-115-B.....	6
8	Radio Transmitter BC-375-E, Tube Compartment Shield Removed and Transmitter Tuning Unit TU-5-B Being Inserted.....	8
9	Radio Transmitter BC-375-E, Filament Resistor and Terminal Board.....	9
10	Antenna Reactance Curve.....	12
11	Radio Transmitter BC-375-E, Functional Diagram of Radio-Frequency and High-Voltage Circuits.....	17
12	Radio Transmitter BC-375-E, Functional Diagram of Antenna Tuning Circuits.....	18
13	Radio Transmitter BC-375-E, Functional Diagram of Audio-Frequency Circuits—Tone Operation.....	19
14	Radio Transmitter BC-375-E, Functional Diagram of Audio-Frequency Circuits—CW Operation (Side Tone).....	20
15	Radio Transmitter BC-375-E, Functional Diagram of Audio-Frequency Circuits—Voice Operation.....	21
16	Radio Transmitter BC-375-E, Functional Diagram of Low-Voltage and Control Circuits.....	21
17	Tube VT-4-C, Characteristic Curves.....	22
18	Tube VT-25, Characteristic Curves.....	23
19	Antenna Tuning Unit BC-306-A, Schematic Diagram.....	23
20	Dynamotor Unit PE-73-C, Schematic Diagram.....	24
21	Antenna Tuning Unit BC-306-A, Interior View.....	55
22	Dynamotor Unit PE-73-C (with Oil Hole and Screw Plug), Mounting FT-107 and Low-Voltage End Bell Removed.....	56
22A	Dynamotor Unit PE-73-C (without Oil Hole and Screw Plug), Mounting FT-107 and Low-Voltage End Bell Removed.....	57
23	Dynamotor Unit PE-73-C (with Oil Hole and Screw Plug), Mounting FT-107 and High-Voltage End Bell Removed.....	58
23A	Dynamotor Unit PE-73-C (without Oil Hole and Screw Plug), Mounting FT-107 and High-Voltage End Bell Removed.....	59
24	Dynamotor Unit PE-73-C, Top View, Mounting FT-107 and Relay-Fuse Box Cover Removed.....	60
25	Radio Transmitter BC-375-E, Tube Compartment Shield and Top Cover Off and Transmitter Tuning Unit in Place.....	61
26	Radio Transmitter BC-375-E, Left Rear View, with Shields Removed and with Mounting FT-151-A.....	62
27	Radio Transmitter BC-375-E, Right Rear View, with Shields Removed and with Mounting FT-151-A.....	63
28	Radio Transmitter BC-375-E, Bottom View, Mounting FT-151-A and Shields Removed.....	64
29	Transmitter Tuning Unit TU-5-B, Top View, Cover Removed.....	65
30	Transmitter Tuning Unit TU-5-B, Bottom View, Cover Removed.....	65
31	Transmitter Tuning Unit TU-6-B, Top View, Cover Removed.....	66
32	Transmitter Tuning Unit TU-6-B, Bottom View, Cover Removed.....	66
33	Transmitter Tuning Unit TU-7-B, Top View, Cover Removed.....	67
34	Transmitter Tuning Unit TU-7-B, Bottom View, Cover Removed.....	67
35	Transmitter Tuning Unit TU-8-B, Top View, Cover Removed.....	68
36	Transmitter Tuning Unit TU-8-B, Bottom View, Cover Removed.....	68
37	Transmitter Tuning Unit TU-9-B, Top View, Cover Removed.....	69
38	Transmitter Tuning Unit TU-9-B, Bottom View, Cover Removed.....	69
39	Transmitter Tuning Unit TU-10-B, Top View, Cover Removed.....	70

LIST OF ILLUSTRATIONS (Continued)

Figure		Page
40	Transmitter Tuning Unit TU-10-B, Bottom View, Cover Removed	70
41	Transmitter Tuning Unit TU-26-B, Top View, Cover Removed	71
42	Transmitter Tuning Unit TU-26-B, Bottom View, Cover Removed	71
43	Antenna Tuning Unit BC-306-A, Connection Diagram	72
44	Antenna Tuning Unit BC-306-A, Outline Dimensional Sketch	73
45	Case CS-48, Outline Dimensional Sketch	74
46	Dynamotor Unit PE-73-C, Connection Diagram	75
47	Dynamotor Unit PE-73-C, Outline Dimensional Sketch	76
48	Mounting FT-115-B, Outline Dimensional Sketch	77
49	Radio Transmitter BC-375-E, Schematic Diagram	78
50	Radio Transmitter BC-375-E, Connection Diagram	79
51	Radio Transmitter BC-375-E, Outline Dimensional Sketch	80
52	Transmitter Tuning Units, Schematic Diagrams	81
53	Transmitter Tuning Unit TU-5-B, Connection Diagram	82
54	Transmitter Tuning Unit TU-6-B, Connection Diagram	83
55	Transmitter Tuning Unit TU-7-B, Connection Diagram	84
56	Transmitter Tuning Unit TU-8-B, Connection Diagram	85
57	Transmitter Tuning Unit TU-9-B, Connection Diagram	86
58	Transmitter Tuning Unit TU-10-B, Connection Diagram	87
59	Transmitter Tuning Unit TU-26-B, Connection Diagram	88

)

)

)

)

)

SUPPLEMENT TO INSTRUCTION BOOK FOR OPERATION AND MAINTENANCE OF RADIO TRANSMITTER BC-375-E

Certain constructional changes in Radio Transmitter BC-375-E and associated equipment may be noted from time to time. These modifications, such as redesigned shields, are made in the interest of strategic metal conservation, and will alter the physical appearance of the units only slightly.

CASE CS-48

An all-black steel case as well as the earlier aluminum type may be found in current use. The same exacting standards have been followed in the manufacture of this model so that the two may be used interchangeably.

MOUNTINGS

Several mountings have been redesigned, but may be used interchangeably with earlier models of the same nomenclature. (See Figures A, B and C.) In these units also, steel has been substituted for aluminum, but

the new designs are such that weight differences between current and older models will be found to be practically negligible. Dimensions and weights of the new mountings, Mountings FT-107-B, FT-142-A, and FT-151-C, are given in the table below.

Description	Dimensions in Inches H×W×D	Wt. in Pounds
Mounting FT-107-B	$\frac{5}{32} \times 10\frac{5}{8} \times 7\frac{1}{2}$	1.347
Mounting FT-142-A	$.094 \times 9\frac{1}{2} \times 7\frac{1}{4}$	0.735
Mounting FT-151-C	$1.352 \times 22 \times 8$	3.50

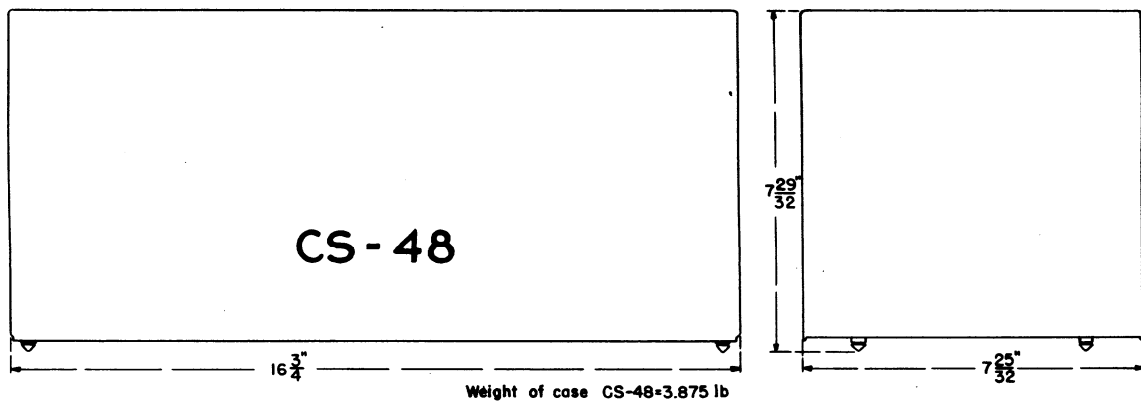

NEW STEEL CASE CS-48, OUTLINE DIMENSIONAL SKETCH

SIGNAL CORPS STOCK NUMBERS

Name of Part	Stock Number
Antenna Tuning Unit BC-306-A less mounting	2C516A/1
Radio Transmitter BC-375-E, less tubes and mounting	2C6365E.1
Dynamotor Unit PE-73-C, less mounting	3H1873C.1
Package of Maintenance Parts	2S287AT.6/MP
Vacuum Tube VT-4-C	2T4C
Vacuum Tube VT-25	2T25
Transmitter Tuning Unit TU-5-B	2C8005B
Transmitter Tuning Unit TU-6-B	2C8006B
Transmitter Tuning Unit TU-7-B	2C8007B
Transmitter Tuning Unit TU-8-B	2C8008B
Transmitter Tuning Unit TU-9-B	2C8009B
Transmitter Tuning Unit TU-10-B	2C8010B
Transmitter Tuning Unit TU-26-B	2C8026B
Case CS-48*	2Z1848
Mounting FT-107	3H3907
Mounting FT-142	2Z6682
Mounting FT-151-A	2Z6691A
Mounting FT-107-B	3H3907B
Mounting FT-142-A	2Z6682A
Mounting FT-151-C	2Z6691C
Mounting FT-115-B	2Z6665B

* A transmitter tuning unit and Case CS-48 are packed together in one carton.

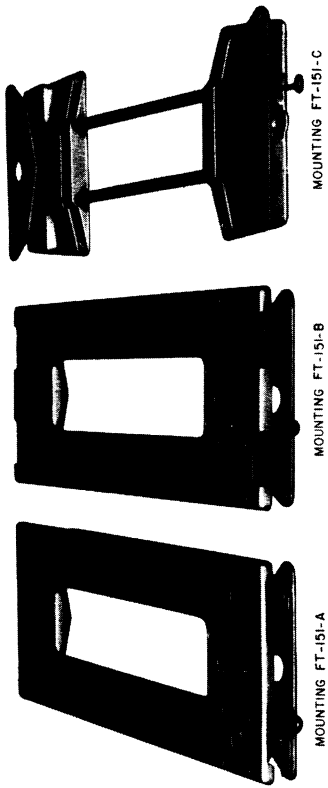

FIGURE A MOUNTINGS FT-151-A, FT-151-B, AND FT-151-C

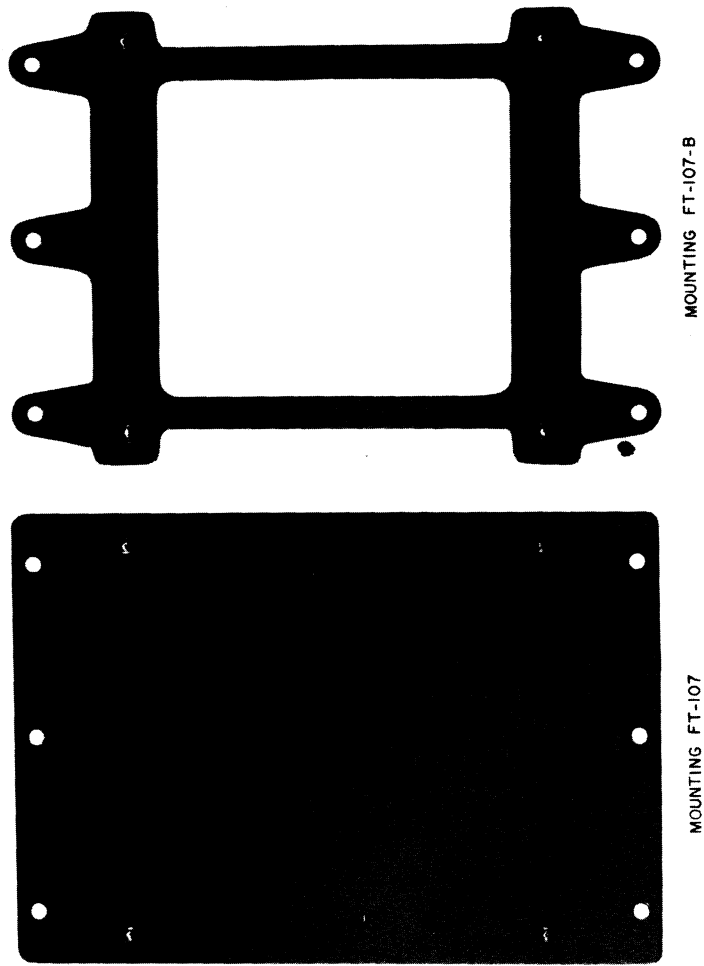
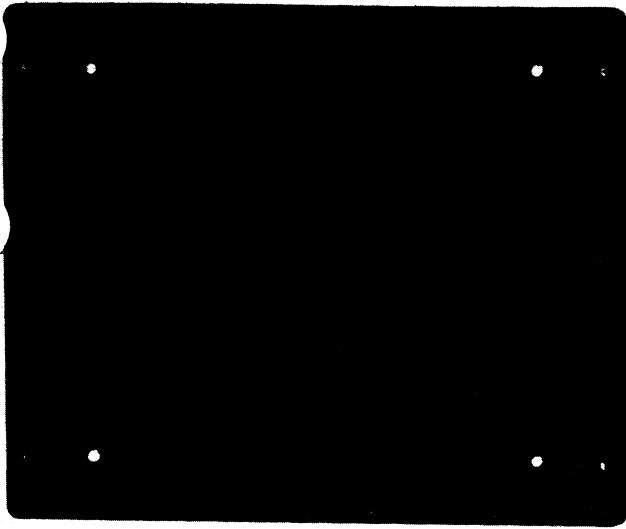
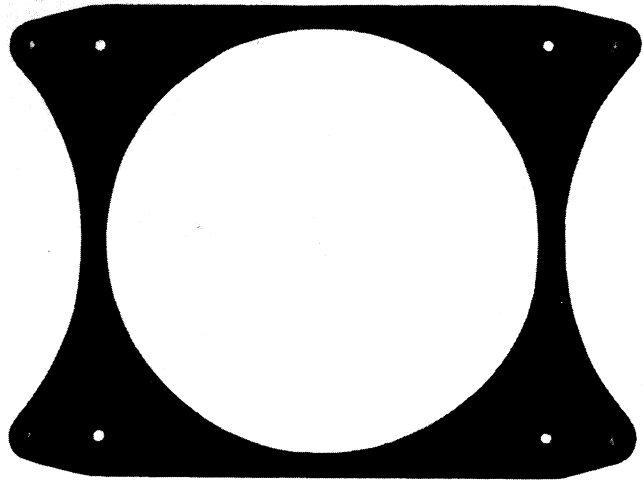

FIGURE B MOUNTINGS FT-107 AND FT-107-B



MOUNTING FT-142



MOUNTING FT-142-A

FIGURE C MOUNTINGS FT-142 AND FT-142-A

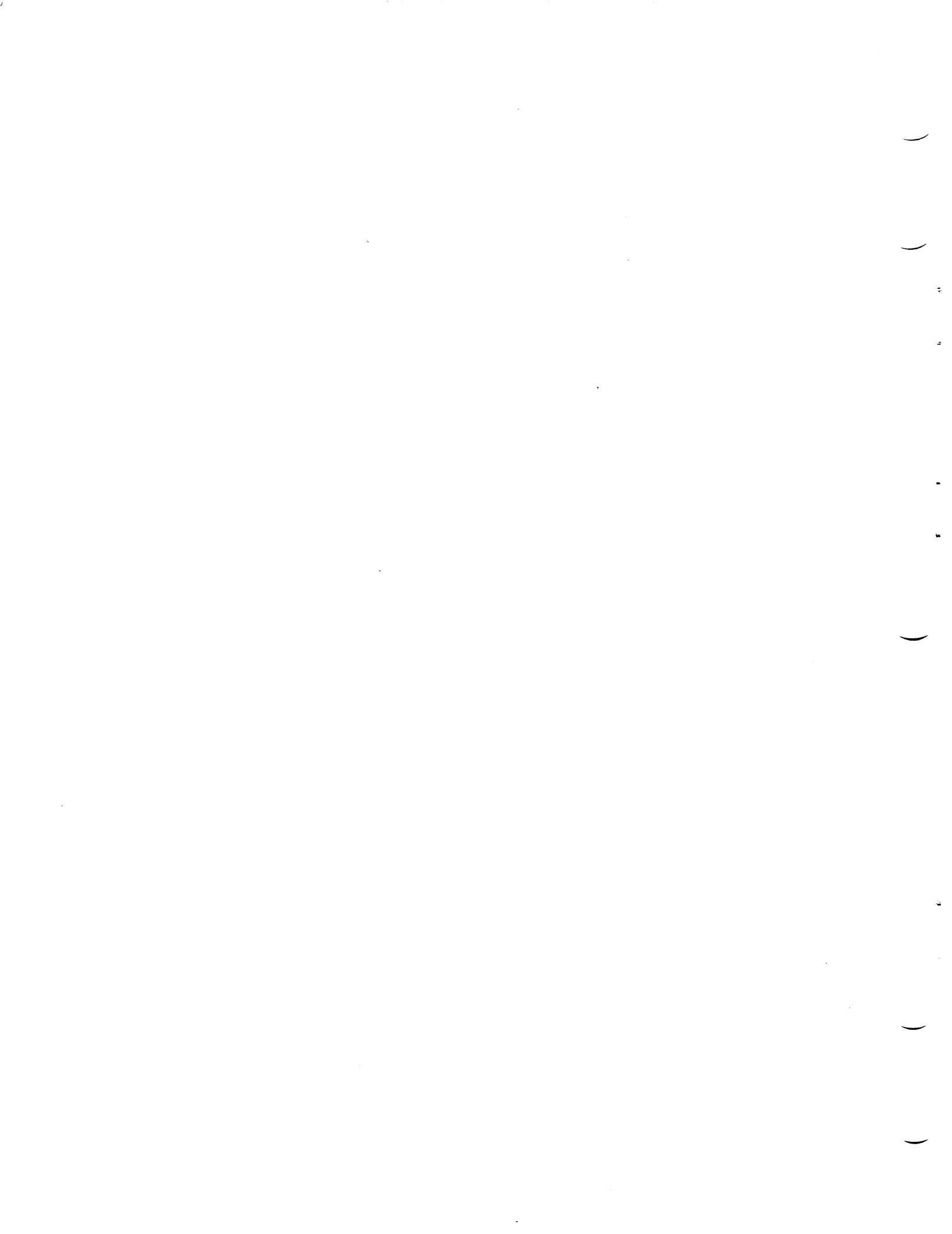

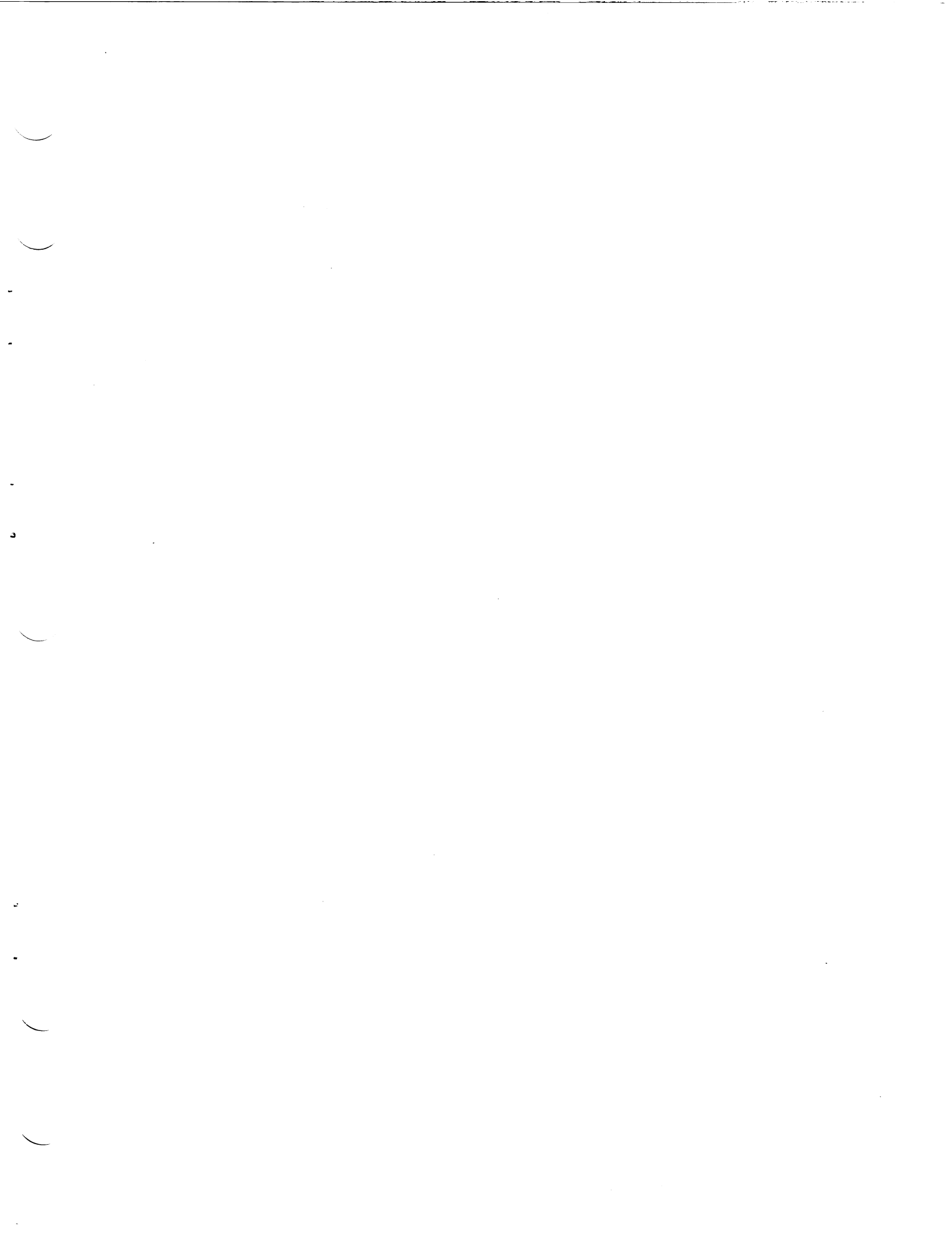

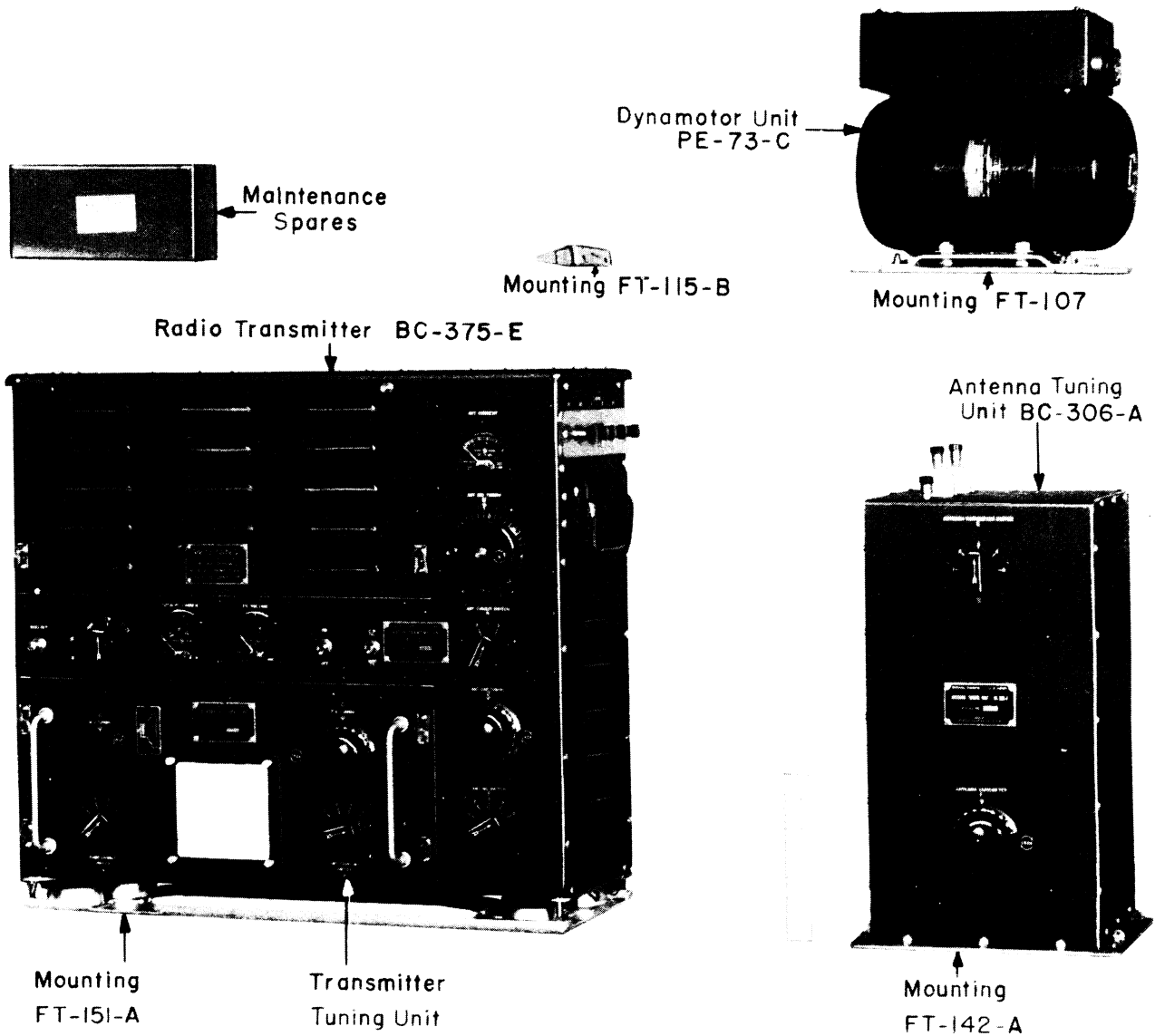

FIGURE 1. RADIO TRANSMITTER BC-375-E AND ASSOCIATED EQUIPMENT

SECTION I—DESCRIPTION

1. GENERAL

Radio Transmitter BC-375-E with its associated equipment is designed for aircraft and other applications requiring a medium power equipment with the characteristics of strength, light weight, flexibility, and portability. The equipment is designed to provide communication by voice, tone, or continuous-wave telegraphy over the frequency range of 150 to 12,500 kilocycles. However, only the frequencies covered by the Transmitter Tuning Units listed in paragraph 16 are available for use with this equipment. Suitable tuning equipment is provided in the radio transmitter to permit operation into a wide range of antennas over most of the frequency range. Antenna Tuning Unit BC-306-A may be used to extend the range of antenna tuning for frequencies between 150 and 800 kilocycles.

Dynamotor Unit PE-73-C furnishes the power

required by the radio transmitter and operates from a 24/28 volt storage battery or other direct-current source used in aircraft. The input power when operating on continuous-wave telegraph will be approximately 600 watts. The fully modulated voice transmission will require 840 watts input power.

Because of the flexibility with which it can be adapted to fit different requirements and conditions of operation, Radio Transmitter BC-375-E may be used as an item of a number of different radio sets. The other items, such as tuning unit, cords, etc., will be listed in the "Parts List" of each set.

2. ANTENNA TUNING UNIT BC-306-A (INCLUDES MOUNTING FT-142)

This unit consists of a painted duralumin case which houses a variometer 1502, control F; and a switch 1501, control E. Sufficient inductive reactance is provided in this unit, in addition to the reactance provided in the radio transmitter and transmitter tuning units, to resonate antennas whose effective capacitance varies as indicated below:

Frequency Range	Effective Capacitance Range
150-350 kc	1000-1500 mmfds
350-800 kc	350-800 mmfds

The controls permit a continuous variation of the inductive reactance. Suitably insulated binding posts are located on the top shield. Four snap-slide catches are used to attach the unit to Mounting FT-142.

The terminals at the top of the antenna tuning unit are for interconnection between the "loading" terminals of the radio transmitter when operating on frequencies above 400 kilocycles. For operation on frequencies below 400 kilocycles, the antenna tuning unit is connected in the antenna circuit and the two "loading" terminals are connected as described in section II, EMPLOYMENT.

3. CASE CS-48

This case consists of an individual metal container into which any one of the transmitter tuning units may be inserted and mounted or carried. The tuning unit is secured in the case by the same four snap-slide catches that are used to secure the unit in the radio transmitter.

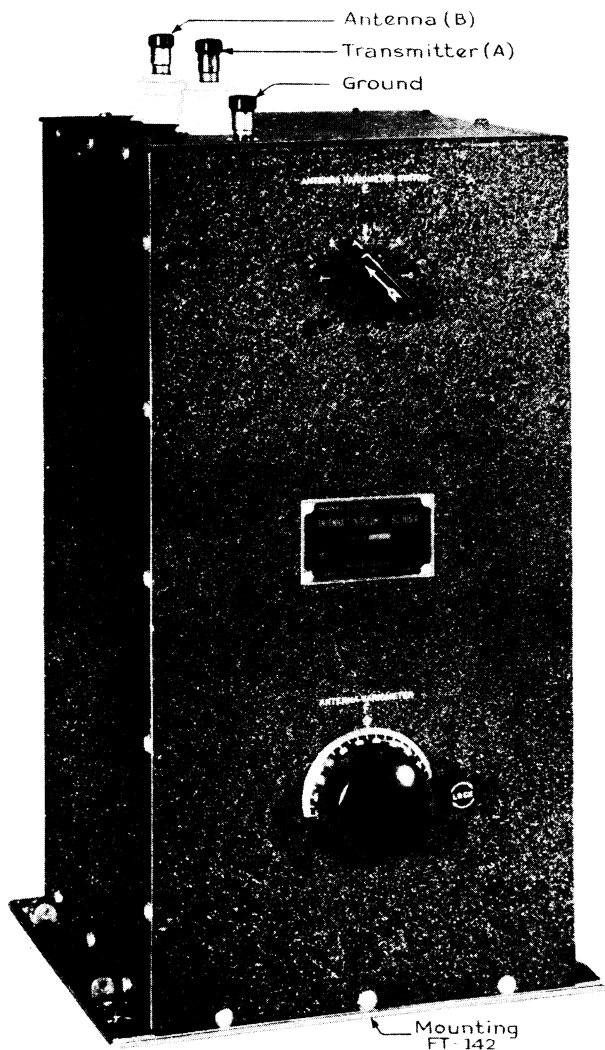

FIGURE 2. ANTENNA TUNING UNIT BC-306-A

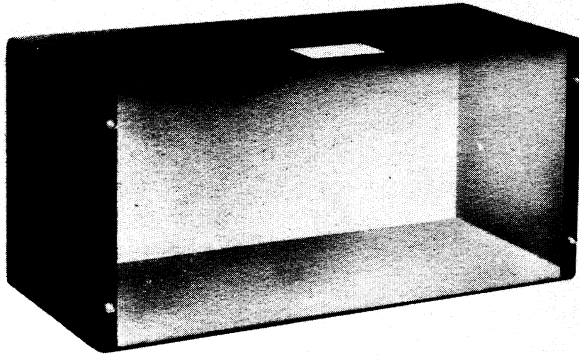

FIGURE 3. CASE CS-48

4. DYNAMOTOR UNIT PE-73-C (INCLUDES MOUNTING FT-107)

Dynamotor Unit PE-73-C consists of a dynamotor upon which is mounted a box containing the relay, fuses, sockets, capacitors, etc. The dynamotor proper is a two-pole, totally-enclosed, ball-bearing,

d-c to d-c rotating machine. It is rated at 28 volts, 20 amperes input; 1000 volts, 0.35 amperes output, at 5000 rpm, with 55 deg. Centigrade rise for 1/2 hour intermittent duty. It has been designed to give efficient, reliable service over long periods of time with a minimum of attention. Skeleton type bearing brackets on each end afford maximum accessibility to the commutators and brushes. The portion of the armature winding between each commutator and armature core is securely bound with cord and thoroughly impregnated, thus affording a mechanical protection for the armature winding against injury from moisture, dirt, and abrasion. The external leads of the dynamotor go directly into the relay-fuse box through two bushings in the top of the magnet frame.

A totally-enclosed, solenoid-type starting relay, particularly designed to withstand vibration, sudden shock and acceleration as encountered in aircraft installation, is used. The double-break contacts are sufficiently large to carry the heavy starting current of the dynamotor.

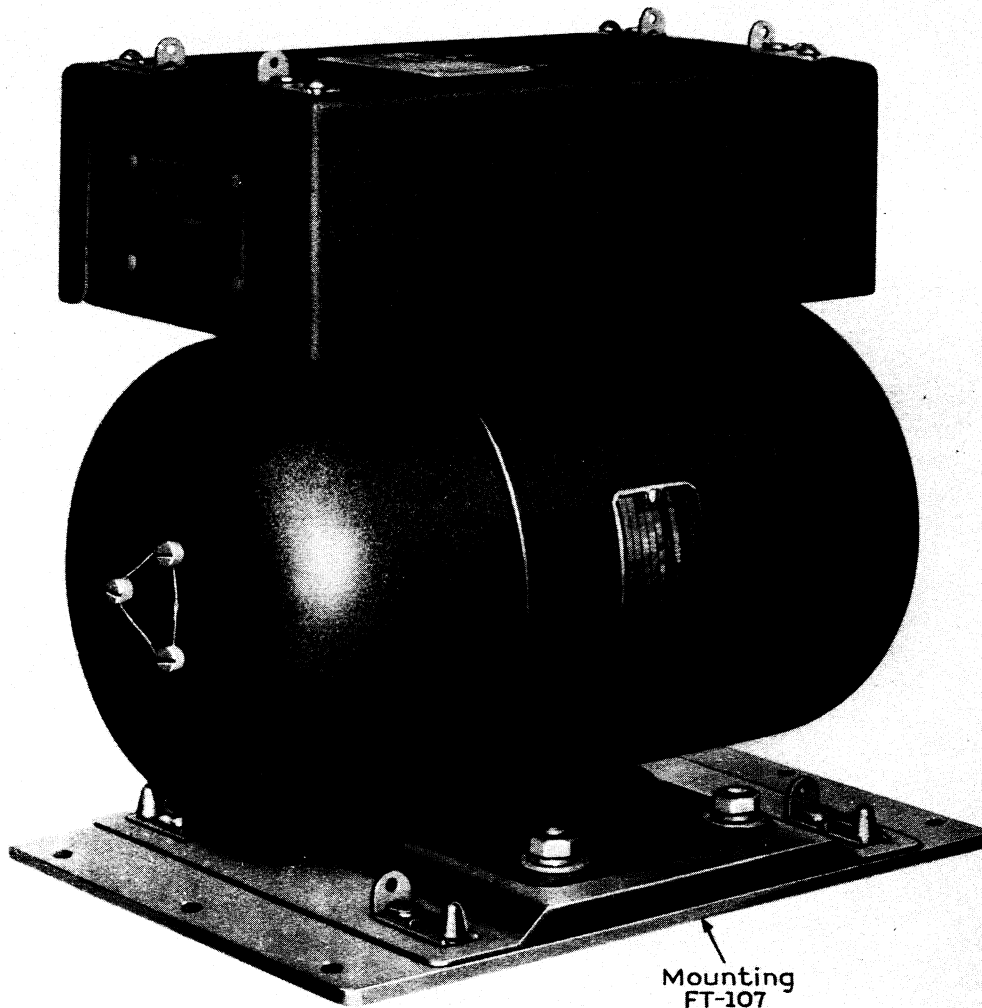

FIGURE 4. DYNAMOTOR UNIT PE-73-C

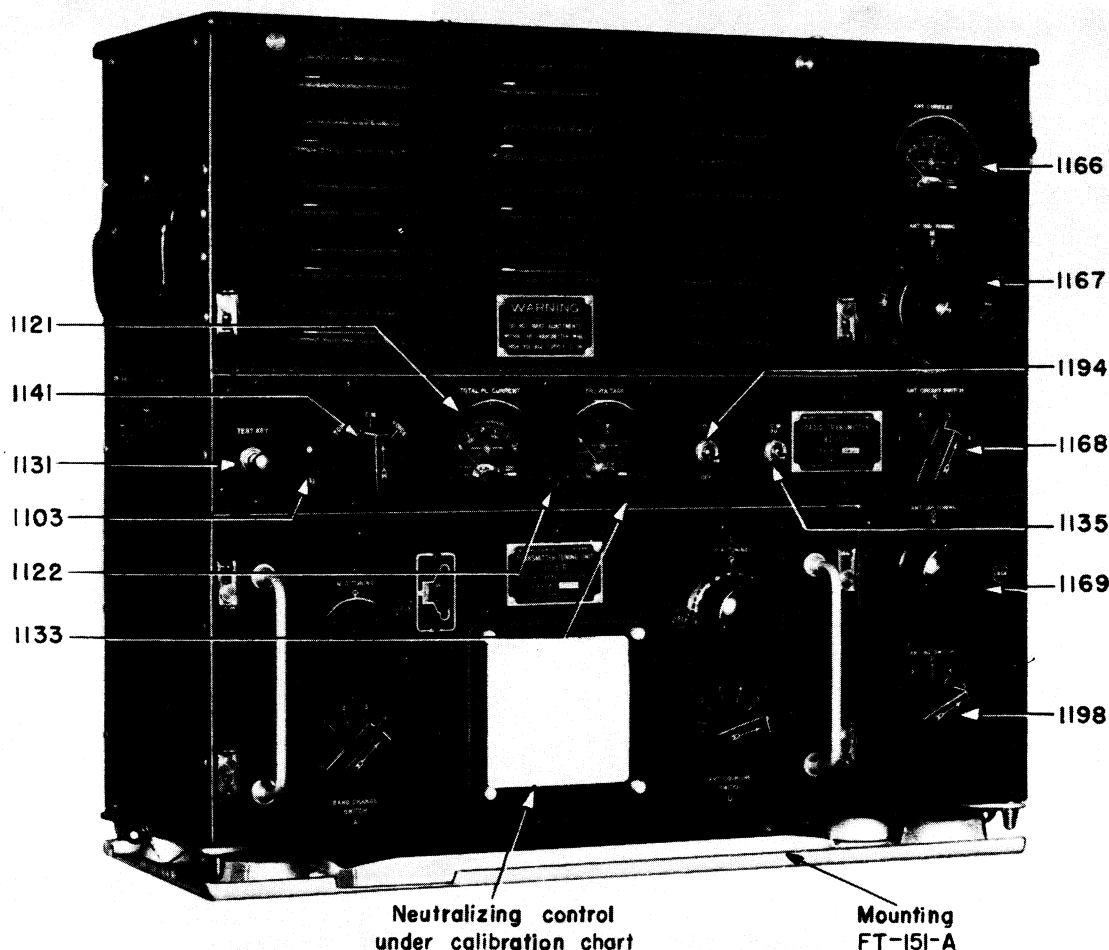

FIGURE 5. RADIO TRANSMITTER BC-375-E, TRANSMITTER TUNING UNIT TU-5-B IN PLACE

The input binding posts and fuse clips are mounted on and securely pinned to a molded terminal board. In addition, all fuse clips and terminals are soldered to their mounting screws so as to insure a tight, low resistance, electrical contact.

Four snap-slide catches are employed to fasten the cover to the relay-fuse box. A spare H-V fuse, spare fuse links, and a socket wrench are carried in clips inside of this cover. In one end of the relay-fuse box are mounted Socket SO-39 and Socket SO-41. A $\frac{15}{16}$ in. diameter hole for entrance of a conduit containing the two power-input leads is provided between these sockets.

A radio-frequency interference filter is included. This is designed to eliminate objectionable noise in associated receiving equipment due to operation of the dynamotor alone. The filter consists of capacitors connected so as to by-pass various dynamotor circuit points and give maximum noise suppression.

5. RADIO TRANSMITTER BC-375-E (INCLUDES MOUNTING FT-151-A)

Radio Transmitter BC-375-E consists of a shielded metal cabinet containing the necessary vacuum tubes, sockets, antenna tuning equipment, audio-frequency circuits, input and output terminals and plug connectors for connection to the radio-frequency circuits contained in the transmitter tuning units. The circuits of this unit are shown in Figure 49, and its external dimensions are shown in Figure 51.

The radio transmitter frame is constructed of seamless chrome-molybdenum steel tubing. Shields are attached to this frame by means of button-head machine screws in all cases except the front tube compartment shield, which is fastened by means of snap catches. Vacuum tubes are mounted in the upper front portion of the frame and are readily accessible by removal of the aforementioned tube compartment shield. The right-hand side of the frame includes the antenna tuning equipment. The test key,

Pars. 5-8

signal switch, filament voltage, and plate current meters, indicator lamp, on-off switch and voltmeter switch are mounted on a narrow panel below the tube compartment. Access to the calibration reset capacitor is gained through a small port in this panel. The bottom front portion of the radio transmitter is provided with accurately fitted guides to receive the transmitter tuning units which are slid into place so that the tuning unit panel forms the bottom front portion of the radio transmitter panel. Sockets and a jack for external power and control circuit connections are provided on the left-hand side of the radio transmitter.

The radio transmitter uses five vacuum tubes as follows:

- 1—Tube VT-4-C as master oscillator
- 1—Tube VT-4-C as power amplifier
- 2—Tubes VT-4-C as class B modulators
- 1—Tube VT-25 as speech amplifier or audio-frequency oscillator

6. TRANSMITTER TUNING UNITS TU-5-B, ETC.

There are seven transmitter tuning units covering the frequency range of 200 to 500 and 1500 to 12,500 kilocycles, as listed below.

- a. TU-5-B 1500-3000 kc
- b. TU-6-B 3000-4500 kc
- c. TU-7-B 4500-6200 kc
- d. TU-8-B 6200-7700 kc
- e. TU-9-B 7700-10,000 kc
- f. TU-10-B 10,000-12,500 kc
- g. TU-26-B 200-500 kc

Each of these units consists of a duralumin case in which are housed the radio-frequency circuits for the master oscillator and power amplifier. The unit is plugged into the radio transmitter, its front panel forming a part of the radio transmitter front panel. The circuits of all transmitter tuning units are shown in Figure 52. The tuning unit panel contains the following controls: band-change switch, Control A (used only when tuning controls do not cover the complete frequency range); master-oscillator tuning, Control B; power amplifier tuning, control C; antenna coupling switch, control D, and neutralizing capacitor control. Since the neutralizing capacitor does not require adjustment in service, it is made accessible only by removal of the tuning chart which is mounted on the front panel.

7. CO-ORDINATION OF UNITS

The various units previously described, when connected by their respective cords, comprise the transmitting equipment of a radio set. The following additional items are necessary to make a complete operative installation.

- a. Radio receiving equipment including head-sets
- b. Suitable antenna system
- c. Microphone T-17, or equivalent
- d. Hand telegraph key
- e. Primary power source
- f. Plugs and cordage

8. AIRCRAFT RADIO SETS

In aircraft radio sets, the receiving equipment is interconnected with the transmitting equipment so

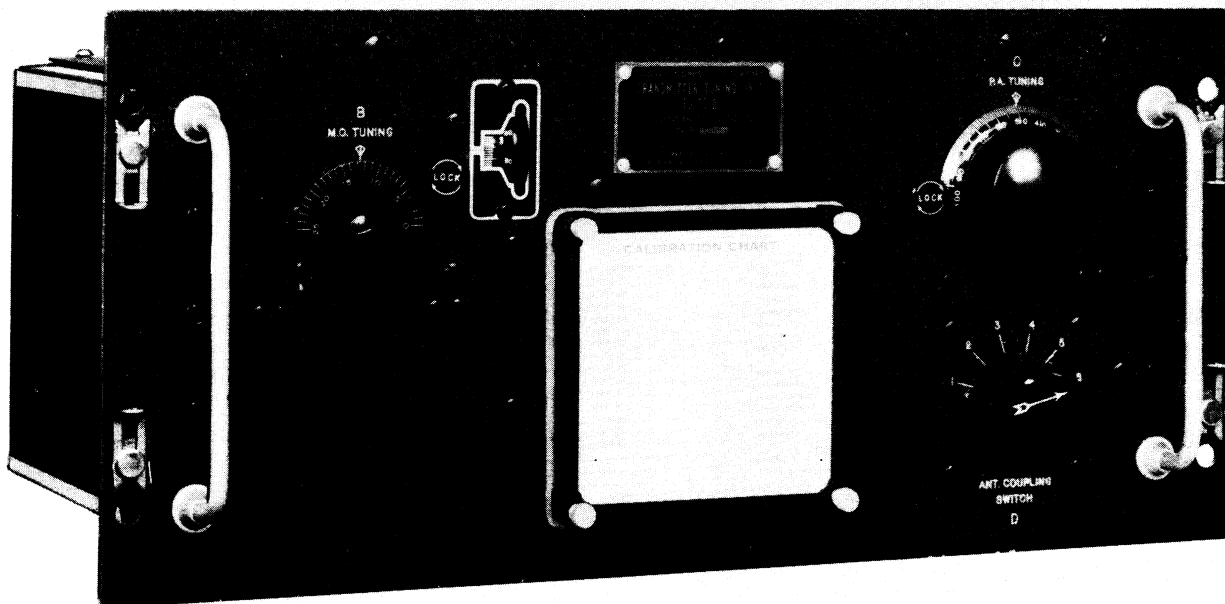

FIGURE 6. TYPICAL FRONT VIEW OF A TRANSMITTER TUNING UNIT WITHOUT A BAND CHANGE SWITCH

that they are co-ordinated for break-in operation. The radio receiver can be operated when the radio transmitter is either OFF or ON provided that neither the telegraph key nor the microphone switch is depressed. It is impossible for the radio transmitter and radio receiver to be operative at the same time; that is, the keying relay in the radio transmitter, when it causes the radio transmitter to function, at the same time open-circuits the receiver plate or screen-grid supply and only transmitter side tone is heard in the headset. When the keying relay opens, radio transmitter output ceases and the receiver plate or screen-grid supply is restored. The radio transmitter is made ready for operation by its OFF-ON switch and transmission is controlled by the telegraph key or the microphone switch.

9. LIST OF MAIN UNITS

The following tabulation gives the sizes and weights of the main units.

Description	Dimensions in Inches H x W x D	Wt. in Lb
Antenna Tuning Unit BC-306-A	17 ³ / ₄ x 9 ¹ / ₂ x 9 ¹ / ₈	9.75
Weight less Mounting FT-142		9.062
Case CS-48	7 ⁷ / ₈ x 16 ³ / ₄ x 7 ²⁹ / ₃₂	4.375
Dynamotor Unit PE-73-C	10 ²⁹ / ₃₂ x 11 ¹ / ₁₆ x 7 ¹ / ₂	38.70
Weight less Mounting FT-107		37.25
Mounting FT-107	1 ³ / ₁₆ x 10 ⁵ / ₈ x 7 ¹ / ₂	1.45
Mounting FT-115-B	1 ⁷ / ₃₂ x 2 ¹ / ₈ x 2 ⁵ / ₁₆	0.195
Mounting FT-142	1 ³ / ₂ x 9 ¹ / ₂ x 8	0.69
Mounting FT-151-A	1.352 x 22 x 8	3.75
Radio Transmitter BC-375-E (without tubes or tuning units)	21 ²¹ / ₃₂ x 23 ¹ / ₈ x 9 ⁵ / ₁₆	52.75
Weight less Mounting FT-151-A		49.0
Transmitter Tuning Unit TU-5-B	7 ⁵ / ₈ x 16 ³ / ₄ x 8 ³ / ₄	14.437

Description	Dimensions in Inches H x W x D	Wt. in Lb
Transmitter Tuning Unit TU-6-B	7 ⁵ / ₈ x 16 ³ / ₄ x 8 ³ / ₄	12.437
Transmitter Tuning Unit TU-7-B	7 ⁵ / ₈ x 16 ³ / ₄ x 8 ³ / ₄	11.687
Transmitter Tuning Unit TU-8-B	7 ⁵ / ₈ x 16 ³ / ₄ x 8 ³ / ₄	11.437
Transmitter Tuning Unit TU-9-B	7 ⁵ / ₈ x 16 ³ / ₄ x 8 ³ / ₄	11.437
Transmitter Tuning Unit TU-10-B	7 ⁵ / ₈ x 16 ³ / ₄ x 8 ³ / ₄	11.437
Transmitter Tuning Unit TU-26-B	7 ⁵ / ₈ x 16 ³ / ₄ x 8 ³ / ₄	12.750
Tube VT-4-C	2 ⁵ / ₁₆ dia. x 7 ⁷ / ₈ long	0.46
Tube VT-25	2 ³ / ₁₆ dia. x 5 ⁵ / ₈ long	0.125
1 Carton of Maintenance Parts. This carton contains:	2 ³ / ₄ x 3 ⁷ / ₈ x 7 ⁷ / ₈	1.75
4—Brushes BR-5, Dynamotor H.V.		
4—Brushes BR-6, Dynamotor L.V.		
2—Fuses FU-12-A		
2—Fuses FU-13		
2—Fuses FU-18-A		
2—Fuses FU-22		
6—Fuse Links M-141		
6—Fuse Links M-168		
4—Set Screw Wrenches		
1/4 Pt. of Glyptal Varnish No. 1153		

SECTION II—EMPLOYMENT

10. INSTALLATION

Radio Transmitter BC-375-E and associated equipment are part of the aircraft radio sets. Installation conditions vary widely and no detailed single set of installation instructions can be given in this book. However, separate instructions are furnished for each radio set and only such general instructions as should be followed in all installations are given in the following paragraphs.

The requirements for shielding and bonding of cords in aircraft installations are very rigid, in order that difficulties with the receiver side-tone pick-up and radio frequency from the power supply will be minimized.

a. Radio Transmitter BC-375-E

The radio transmitter outline dimensions and weights are shown in Figure 51.

The radio transmitter should be located in relation to its associated equipment so that dynamotor unit and antenna leads will be of minimum length.

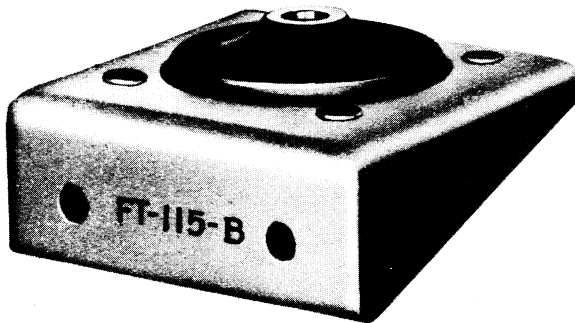

FIGURE 7. MOUNTING FT-115-B

Two types of shock-absorber mountings are available for use with the radio transmitter: Mounting FT-151-A, tray-type; and Mounting FT-115-B, disposable-type. The tray-type mounting, to which the radio transmitter is attached by four snap-slide catches, is used to support the radio transmitter with one or more of the disposable mountings added near the top of the radio transmitter to prevent swaying. Mounting FT-115-B consists of a rubber button in a steel shell which may be attached to the top, bottom, or sides of the radio transmitter. Certain transmitter-cover fastening screws have been placed so as to allow attachment of this mounting.

The radio transmitter should not be mounted closer than two inches from a wall. The power cords should not be fastened nearer than 12 inches from the transmitter. This precaution prevents vibration from being transmitted to the unit through the cords. It is

important that sufficient space be allowed in the front of the radio transmitter to facilitate replacement of tubes, removal of transmitter tuning units, and the making of tuning adjustments. After installation has been completed and tested, the snap-slide catches should be securely safety wired at the places provided.

b. Dynamotor Unit PE-73-C

Outline dimensions and weight are shown in Figure 47. The dynamotor unit should be mounted in the proper position to allow access to the relay-fuse box, keeping in mind that the length of the leads from the battery to the dynamotor unit must be as short as practicable. This unit when operated in conjunction with Radio Transmitter BC-375-E draws from 20 to 30 amperes. No. 6 AWG, or larger conductor, should therefore be used for these leads in order to keep the voltage drop at a minimum. Mounting FT-107 should be securely attached so that the dynamotor unit cannot be torn loose by acceleration, vibration, or shock.

After the dynamotor unit is clamped securely to Mounting FT-107 by means of the four snap-slide catches, Plug PL-59 and Plug PL-61 of the applicable cords should be plugged into Socket SO-39 and Socket SO-41, respectively, on the dynamotor unit. The primary leads from the battery or junction box should then be clamped securely to the proper binding posts on the dynamotor unit terminal board.

c. Cords

The cords or plugs and cordage to be used with the various radio sets are listed in the parts lists for same.

d. Antennas

Because of the wide variety of antennas in the radio sets of which Radio Transmitter BC-375-E is a part, no specific details will be given for antenna installations. However, the following general precautions should be observed:

- (1) The antenna and ground leads should be made as short as possible, except where the length of lead-in is definitely determined by the placement of radio set and antenna.
- (2) Antenna leads should be insulated to withstand radio-frequency potentials as high as 5000 volts.
- (3) Antenna leads should be so placed that operating personnel will not come in contact with them during normal operation of the equipment. Points accessible to personnel should be covered with steatite beads.

(4) Ground connections should have as low a resistance as possible. In aircraft installations the ground path should be well bonded. The GND post should always be connected to the ground system by a short lead, allowing, of course, for flexure due to vibration and shock. A link will be required between posts LOADING A and LOADING B when Antenna Tuning Unit BC-306-A is not used. This antenna tuning unit is not recommended when frequencies above 800 kilocycles are used.

(5) Antenna leads between the antenna and the radio transmitter and between the radio transmitter and the receiver should be located as far as possible from any primary wiring of the airplane. This applies especially to the wiring of the dynamotor unit and is necessary in order to decrease the pickup of electrical interference by the antenna circuit wiring.

e. Antenna Tuning Unit BC-306-A

This tuning unit is provided with Mounting FT-142. It should be mounted so that the tuning controls will be accessible during operation. It is desirable that the length of leads between the radio transmitter and the antenna tuning unit be kept at a minimum and that the leads be well insulated. Outline dimensions and weight are shown in Figure 44.

For operation on frequencies above 400 kilocycles, terminals A—TRANS. and B—ANT. on the antenna tuning unit are connected to LOADING TERMINALS A and B respectively on the radio transmitter. For operation on frequencies below 400 kilocycles, a jumper is placed across LOADING TERMINALS A and B on the radio transmitter. Terminal A—TRANS. on the antenna tuning unit is then connected to the antenna post, marked ANT on the radio transmitter while the antenna connection is made to terminal B—ANT. The post marked GND on the antenna tuning unit should always be connected to the radio transmitter ground.

f. Reel RL-30-B and Connector Clamp MC-163

The reel should be mounted in such a position that the crank is readily accessible and the counter is visible. In order to prevent excessive "piling" when the wire is being reeled in, the reel should be mounted at least six inches above the fairlead and so placed that the point at which the antenna wire leaves the spool is in line with the axis of the fairlead, that is, for best operation there should be no bends in the antenna wire between the point where it leaves the reel and the far end of the fairlead. The four mounting bolts can be inserted in the reel base through the hole provided in the web of the spool. Unless the mounting screws themselves are grounded, a heavy grounding wire or strap should be clamped under the nut of one of the mounting screws for the purpose of thoroughly grounding all metal parts of the reel.

To fasten the antenna wire to the bottom of the spool channel it is first necessary to remove the spool cover by withdrawing it forward over the spool. This can best be done by placing the fingers of both hands on opposite sides of the cover and pressing on the spool with the thumbs. The end of the wire should be looped under the anchor pin in the spool hub and then twisted around the wire proper a few times. The twisted loop should then be placed in the groove and all of the wire wound on the spool by turning the crank in a clockwise direction. At this point the cover should be replaced by passing the wire through the slot opposite the wire opening and pushing the cover over the spool until it rests against the flange on the back plate. The cover should now be rotated so that the wire from the fairlead to the spool will not rub the edges of the wire opening in the cover either when the spool is full or nearly empty. The counter should now be set to zero. This should be done each time the reel is used in order to reduce the error in the reading caused by irregularities in winding.

Electrical connection to the radio transmitter is made by means of Connector Clamp MC-163, the installation of which is as follows:

(1) Remove the brass bushing from Connector Clamp MC-163 by loosening screw in top of cover and fasten the antenna lead from the radio transmitter to this bushing by means of the screw provided.

(2) Replace the bushing in cover and place the connector over the top of the fairlead, clamping it into place by means of the screw in the side of the cover.

(3) Wind the desired amount of Wire W-106 or Wire W-106-A on the spool and feed the free end through the connector clamp and fairlead until it touches the ground below the airplane.

(4) Connect the free end of the wire to the cable loop on Weight WT-7-A or Weight WT-7-B. Considerable care should be taken in making the connection between the antenna wire and the weight cable in order that the joint will run smoothly through the connector clamp when the antenna is being let out or reeled in. The loop formed in the antenna wire should be as small as practicable and the section where the antenna wire is twisted back upon itself should be tapered and made short as a safe joint will permit.

(5) Wind up the antenna wire in the reel until Weight WT-7-A or Weight WT-7-B rests securely in the fairlead socket. Let out the reel in approximately ten feet of the antenna several items (have someone pull lightly on the weight to keep the antenna wire tight) to insure that the connector clamp is working properly and that the joint between the antenna wire and weight cable runs smoothly through the clamp.

Fairlead Extension F-9 is used when the standard Fairlead F-8 is not long enough. It consists of Coupling MC-161 and a 36-inch length of standard phenolic tubing of the same cross section as the tube of Fairlead F-8. The extension is installed by slipping Coupling MC-161 over the top of the fairlead tube so that it covers approximately 3 inches of the tube and then securing it in place by means of one of the clamps provided. The tubing may then be clamped into the coupling by means of the remaining clamp. This tubing may be cut to fit a particular installation, or more than one extension may be used if required.

g. Interconnection with Radio Receiver in Aircraft

It is necessary, in order to minimize receiver noise, that the cord shields be well grounded, and so supported that they cannot rub on other cords or metal surfaces. In order that the radio receiver and the radio transmitter operation will be co-ordinated wires 21 and 22 of Plug PL-64 must be connected in series with the receiver plate supply. These wires are shown on Schematic Diagram Figure 49 and are marked "Key Relay Arm" and "Key Relay Back."

11. PREPARATION FOR USE

After installation and before the equipment is

put into operation, the circuits of all cords and external wiring should be checked to insure compliance with the circuit diagram and the applicable interconnection diagram. This circuit check should be made with all plugs removed from the sockets in the radio transmitter and power unit to determine that all cord and junction box connections are made as indicated on the diagrams. A voltmeter and battery may be used for this purpose. The plugs should be replaced in their respective sockets after this check.

a. Radio Transmitter BC-375-E

The following procedure is recommended for preparing the radio transmitter for use after installation:

- (1) Remove Plug PL-59 from the radio transmitter. Caution: Do not handle the unused plug.
- (2) Remove the tube compartment shield and insert the tubes. From the front of the radio transmitter, progressing from left to right, the tubes are as follows: (See Fig. 8)
 Speech Amplifier; Tube VT-25
 Master Oscillator; Tube VT-4-C
 Power Amplifier; Tube VT-4-C
 Modulator; Tube VT-4-C
 Modulator; Tube VT-4-C

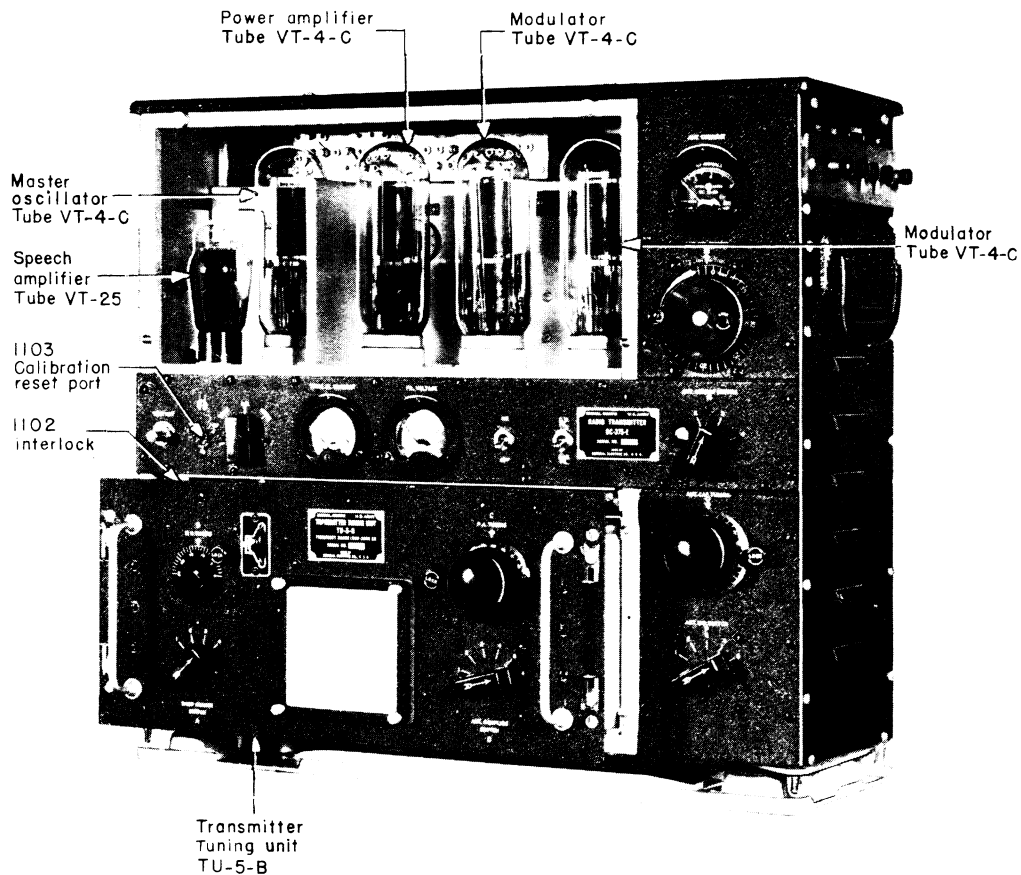

FIGURE 8. RADIO TRANSMITTER BC-375-E TUBE COMPARTMENT SHIELD REMOVED AND TRANSMITTER TUNING UNIT TU-5-B BEING INSERTED

(3) *Filament Adjustment:* (This radio transmitter is for d-c operation only).

(a) Remove all links from the filament resistor connection board. See Figure 9.

(b) Assuming that the primary source voltage is 28 (the terminal voltage of a 24-volt storage battery under charge), place the 24 V./28 V. switch in the tube compartment in the 28.0 volt position.

(c) Set the TONE-CW-VOICE switch on C.W. and the filament voltmeter switch on CW FIL.

(d) Place the OFF-ON switch in the ON position. This should start the dynamotor and apply filament supply potential to the radio transmitter, but not to the tubes. With a screwdriver or a short piece of copper wire, No. 12 B & S or larger, connect between adjacent studs on the 28 V. and CW FILAMENT rows. The CW filaments will light and the filament voltmeter read. Repeat this until the two studs are found, that when connected, will cause the filament voltmeter to read 10 volts. Then place the OFF-ON switch in the OFF position and connect a link between the two studs just selected.

(e) Set the TONE-CW-VOICE switch on VOICE and the filament voltmeter switch on MOD. FIL. Repeat the operation (4) for the 28 V. and MOD. FILAMENT rows of studs.

(f) Again place the OFF-ON switch in the ON position. Set the filament voltmeter switch on CW FIL. (TONE-CW-VOICE switch on VOICE). The CW filament voltage will now be less than 10 volts. In the same manner, connect between the adjacent studs of the COMP. and

CW FILAMENT rows until the filament voltmeter again reads 10 volts. The OFF-ON switch may then be placed in the OFF position and the link fastened in the proper place.

(g) Cut off the charging generator, place the 24 volt/28 volt switch in the 24-volt position and in a similar manner to the preceding select the proper studs on the 24 V. and CW FILAMENT rows and the 24 V. and MOD. FILAMENT rows so that the filament voltmeter will indicate 10 volts in either position. As now adjusted the filament voltages will not require further adjustments unless the cable lengths or charging rates are changed. Ordinarily, in aircraft installations, a battery-charging generator is used at all times. The 24 volt/28 volt switch should accordingly be placed in the 28-volt position.

If it is desired to check the operation of the radio equipment, when the charging generator is below operating speed, this switch should be changed to the 24-volt position since operation at low voltage will reduce the life of the tubes.

(4) Replace Plug PL-59 in the radio transmitter.

Note: It will be noted that the filament voltmeter may read from 0.3 volt to 0.5 volt lower when the radio transmitter key is closed and plate current is being drawn. This is a normal condition of the radio transmitter circuits and should be ignored, providing the above filament adjustments have been made correctly.

b. Dynamotor Unit PE-73-C

Before being used for the first time, it is recommended that the end bells of the dynamotor

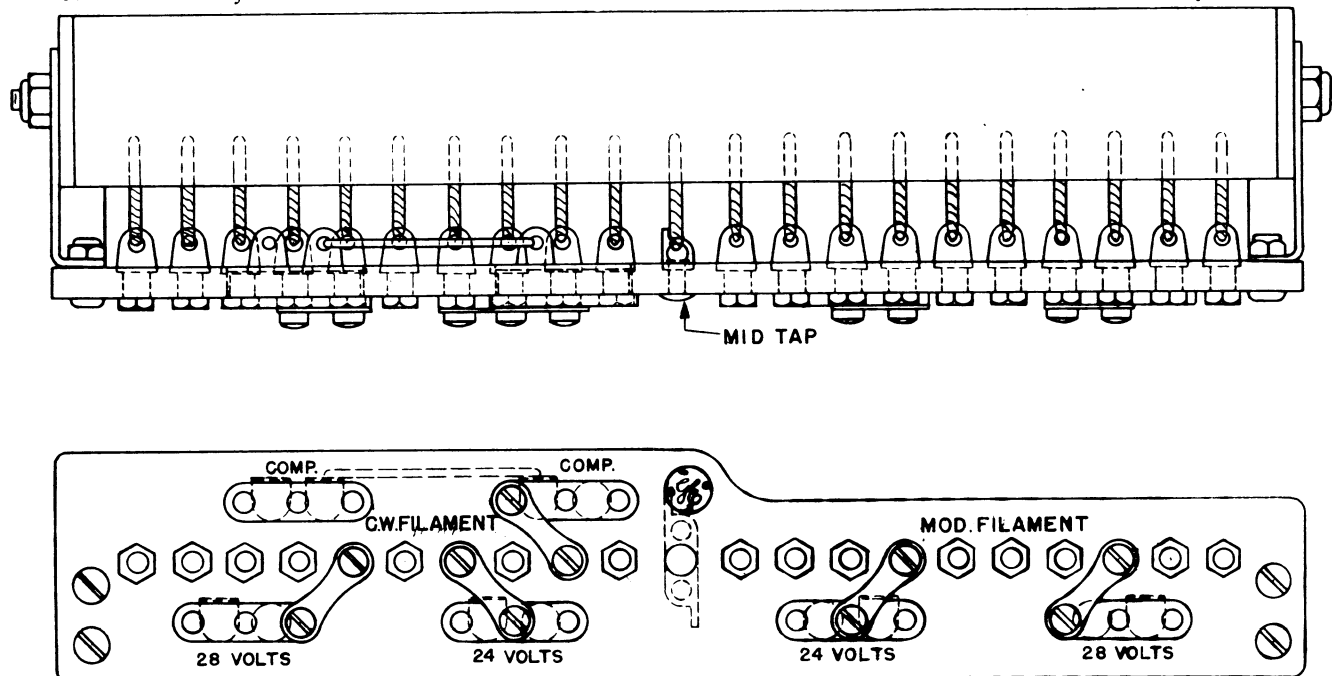

FIGURE 9. RADIO TRANSMITTER BC-375-E, FILAMENT RESISTOR AND TERMINAL BOARD

Pars. 11-12

be removed to make certain that the armature rotates freely in its bearings, and a check should be made to determine how much time has elapsed since the dynamotor unit was last serviced. If this time exceeds five months, follow the lubrication instructions appearing in paragraph 20b. Do not lubricate more often or add more lubricant than is specified in those instructions.

The voltage at the input terminals of the dynamotor unit must be 28 volts in order to obtain rated power output from the radio transmitting equipment.

12. OPERATION

a. At High Altitudes

Radio Transmitter BC-375-E and associated equipment may be expected to give satisfactory service on CW at all altitudes up to 27,000 feet. On TONE and VOICE however, insulation breakdown may be experienced with Transmitter Tuning Unit TU-8-B (6200-7700 kc) above 25,000 feet and with Transmitter Tuning Unit TU-9-B (7700-10,000 kc) above 19,000 feet. These altitude limitations may be exceeded slightly by care in tuning and by carefully guarding against accumulation of dust and other foreign matter in the equipment. Complete assurance of effective operation between 6200 and 10,000 kilocycles at altitudes between 19,000 and 27,000 feet may be had on CW alone. Transmitter Tuning Unit TU-26-B may be expected to give satisfactory service at all altitudes up to 15,000 feet.

b. Transmitter Adjustment

WARNING: OPERATION OF THIS EQUIPMENT INVOLVES THE USE OF HIGH VOLTAGES WHICH ARE DANGEROUS TO LIFE. OPERATING PERSONNEL MUST AT ALL TIMES OBSERVE ALL SAFETY REGULATIONS. DO NOT CHANGE TUBES OR MAKE ADJUSTMENTS INSIDE EQUIPMENT WITH HIGH VOLTAGE SUPPLY ON. DO NOT COMPLETE OR MAINTAIN ANY CONNECTION BETWEEN RADIO TRANSMITTER AND DYNAMOTOR UNIT UNLESS ALL SHIELDS ON THE TRANSMITTER ARE IN PLACE.

Assuming that the installation and preliminary adjustments have been made in accordance with the foregoing instructions, the following operating procedure is recommended. Some of these adjustments need be made only at the time of installation.

Under no conditions should any of the switches on the radio transmitter or tuning unit be changed with the key or microphone button depressed. Insure that all switches position correctly; do not attempt to leave switches between points. Failure to observe this procedure causes undue arcing of the switch and severe strain on the vacuum tubes.

(1) *CW Operation:* Select the transmitter tuning unit for the desired frequency. CW operation may then be obtained as follows:

(a) Place the TONE-CW-VOICE switch on CW.

(b) From the calibration chart on the front of the transmitter tuning unit, set the BAND CHANGE SWITCH A, the M-O TUNING control and the P-A TUNING control for the desired frequency, and set the ANT. COUPLING SWITCH D on Point 1. (It should be remembered that the band change switch does not appear on Transmitter Tuning Units TU-7-B to TU-10-B inclusive.)

(c) Place the OFF-ON switch in the ON position. The dynamotor should now start and the M-O and P-A filaments will light. In case repeated failures of Fuse FU-22 are encountered and if such failures persist after compliance with instructions pertaining to Dynamotor Unit PE-73-C, it is recommended that Fuse FU-22 be removed from the relay-fuse box and one extra Fuse Link M-168 inserted in the fuse cartridge. Fuse FU-22 will then have two fuse links in it and should be replaced in the relay fuse box of the dynamotor unit. In no case should the use of more than two fuse links be attempted.

(d) Press the TEST KEY or the transmitting key. The vacuum tubes will now draw plate current as indicated by the TOTAL PLATE CURRENT meter. The P-A tuning should be checked immediately for resonance by varying the control slightly until a minimum total plate current is indicated. When the P-A circuit is properly resonated, the total plate current will be from 80 to 110 milliamperes.

(e) The antenna should next be tuned to resonance. Because a wide variety of antennas is possible, no specific instructions for antenna tuning are given other than instructions to effect antenna resonance by means of the controls provided on the radio transmitter, and on the antenna tuning unit whenever the latter is in use. The subject of ANTENNA CIRCUITS is considered more in detail in paragraph 12c of this instruction book, and should be referred to in preparation for operation of the equipment.

(f) Antenna resonance is indicated by a reading of current on the ANT. CURRENT meter and by an increase in total plate current. The increase in plate current is the more sensitive indication of approaching antenna resonance. When the antenna is tuned to resonance, the total plate current reading will be somewhat higher than the off-resonance value. If the plate current is below 200 to 220 milliamperes, the coupling to the antenna should be increased by

placing antenna coupling, control D on a higher point and the antenna circuit retuned. When finally adjusted the total plate current should read from 200 to 220 milliamperes. If necessary, detune the antenna circuit slightly keeping the P-A dial, control C, in resonance to keep within the plate current limits.

(g) The equipment is now delivering rated power output, and the transmission may be carried on by operating the transmitting key. In order to shut down the equipment, it is necessary only to place the OFF-ON switch in the OFF position.

(2) *Voice Operation:* Assuming that the equipment has been placed in operation on CW, the following procedure is recommended for obtaining VOICE operation. Note the value of total plate current for CW operation. Then place the TONE-CW-VOICE switch in the VOICE position, and by means of the MOD. BIAS adjustment in the tube compartment, adjust until the total plate current with the microphone switch depressed is approximately 20 to 35 milliamperes higher than for CW. The modulator tubes are now biased nearly to cutoff for proper Class B operation, and radiophone communication may be carried on by speaking into the microphone. It will be noted that the total plate current increases when the microphone is spoken into. This increase is due to current drawn by the modulator tubes. With sustained normal level of speech impressed on the microphone, the plate current should rise to a peak of approximately 300 milliamperes. If this value is not obtained, the INPUT LEVEL control in the tube compartment can be adjusted until the proper amount of modulation, as indicated by the correct plate current, is obtained.

(3) *Tone Operation:* After the equipment has been adjusted for VOICE operation, it is necessary only to place the TONE-CW-VOICE switch on TONE for proper tone telegraph operation. The total plate current on TONE will be between 300 and 350 milliamperes.

(4) *Speech-amplifier Bias:* The correct speech-amplifier bias will usually be found between 6.0 and 7.5 on the S-A BIAS adjustment dial. Settings in this range will normally give the proper speech-amplifier plate current and optimum side-tone frequency on all tuning units. It will usually be found that the speech-amplifier bias settings on radio transmitters received from the factory will require no adjustment.

(5) *Side Tone in Aircraft Set:* If the receiver circuits have been properly co-ordinated with the radio transmitter, the receiver control circuit will operate each time the transmitting key or microphone switch is closed, and the radio transmitter side tone will be supplied to the headset. When the key or the switch is opened, the receiver

again becomes operative, thus allowing break-in operation. The SIDE TONE level control, located in the tube compartment, is used to adjust side tone to a suitable value for any particular installation. Positions 1 and 2 are used for low-level and high-level side-tone signals for the low-impedance headsets (those with the red plug PL-354). Positions 3 and 4 are used for low-level and high-level side-tone signals for the high-impedance sets (those with the black plug PL-54). The operator should determine the type of headset to be used and select the correct side-tone switch position accordingly.

(6) *Calibration Reset:* Due to necessary manufacturing tolerances, the interelectrode capacity of a vacuum tube varies between limits fixed for each particular type of tube. Since the tube capacitance is an appreciable part of any master-oscillator circuit, it is impossible to make up a calibration chart which will be exactly accurate for all tubes whose capacitances are within the allowable limits. For this reason Radio Transmitter BC-375-E is provided with a calibration reset capacitor which enables the operator to reset the transmitter frequency to correspond with the calibration chart when the set is first placed in operation and thereafter whenever the master-oscillator tube is changed. A heterodyne frequency meter or other standard of frequency is required. The procedure is as follows:

(a) With the transmitter tuning unit for the highest available working frequency placed in the radio transmitter, tune the radio transmitter for CW operation on one of the calibrated frequencies at the high frequency end of the band. Use Transmitter Tuning Unit TU-10-B for frequency 11,800 kc, if available. (Approach the calibrated point by proceeding from a lower dial reading to a higher one.)

(b) Allow radio transmitter to warm. The operator will obtain the most accurate results by allowing the transmitter to "warm up" for a period of at least 20 to 30 minutes before setting the calibration reset capacitor or checking the calibrated transmitter frequency.

(c) Place the frequency meter in operation and adjust it to the frequency indicated on the transmitter calibration in accordance with the operating instructions and calibration chart furnished with the frequency meter. The calibration accuracy of this frequency meter should be 0.01 per cent, or better.

(d) Open the calibration reset port, located on the front panel, between the TEST KEY and TONE-CW-VOICE switch, insert a screwdriver, and rotate the calibration reset capacitor until the transmitter frequency coincides with that of the frequency meter or standard.

(e) Close the calibration reset port.

The radio transmitter calibration is now reset for any tuning unit of the same order number and serial number as the radio transmitter and the accuracy of calibration will be within 0.05 per cent plus the accuracy of the standard. The calibration must be checked in this manner each time the M-O tube is changed.

c. Antenna Circuits

The antenna is, in general, a system of conductors which when excited by a radio-frequency voltage, sets up an electromagnetic and electrostatic field causing a component of this field to travel away from the antenna with the velocity of light.

The radiation characteristics of antennas directivity and radiation efficiencies are determined by their physical shape and location with respect to

nant," analogous to a simple-series circuit tuned to resonance.

It may be noted that the "series" resonant points occur at all odd multiples of the first resonant frequency, which is called the fundamental frequency. The fundamental frequency, the third harmonic, and the fifth harmonic, all points of zero reactance, correspond to a voltage distribution along a simple vertical wire of "quarter-wave," "three-quarters wave," and "five-quarters wave." Antennas of this type, operated at zero or low reactances, are commonly called "current fed"; that is, they require low driving voltages for their operation.

At even multiples of the fundamental frequency, it may be seen that the antenna reactance is very high. Operation at the second and fourth harmonics corresponds to "half-wave" and "full-wave" operation. Under these conditions, antennas are "voltage fed"; that is, they require high driving voltages.

The resistance component of the antenna impedance is made of two parts: radiation resistance which represents the radiation of power or waves away from the antenna and which is productive of a useful result; and loss resistance which is a combination of losses due to conductor and ground resistance, and to dielectric hysteresis. Loss resistance performs no useful function and every effort should be made to maintain it very small in comparison with the radiation resistance. The efficiency of an antenna with respect to radiation of power may be expressed as the ratio of radiation resistance to total antenna resistance.

Antenna resistance varies over wide limits with frequency. The resistance values approach very high values at the even harmonics, and minimum values at the odd harmonics. It is thus seen that the operation of a transmitter over a wide frequency band requires that the radio transmitter be capable of providing a considerable range of output voltages. This is accomplished in each transmitter tuning unit by a six point ANT. COUPLING SWITCH, control D. In order that the voltage range required be kept at minimum, antennas are usually "resonated," that is, they are series tuned by either inductance or capacitance, as may be necessary, so that the required output voltage range depends only on the antenna resistance variation over the desired frequency range.

When operating antennas at frequencies lower than their fundamental, or odd harmonics, they appear to the antenna tuning equipment as a capacitance in series with a resistance. In order to balance out this capacitive reactance, it is necessary to load the antenna by means of an inductance, the reactance of which is made equal to that of the apparent antenna capacitance. For operation of antennas at frequencies

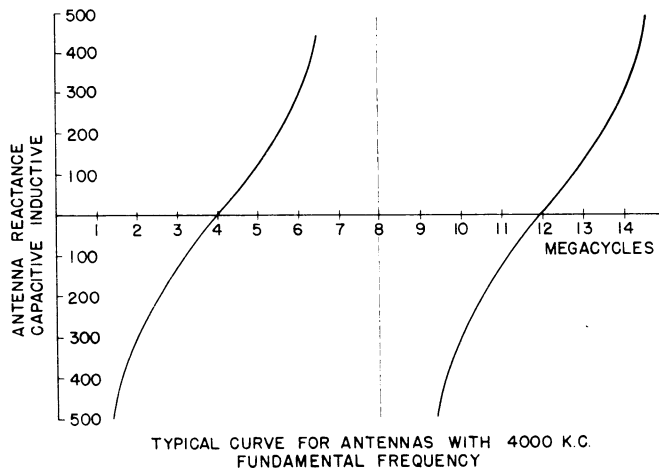

FIGURE 10. ANTENNA REACTANCE CURVE

other bodies. In aircraft, since there is no wide latitude in physical design of fixed antennas, the problem becomes mainly one of determining the best methods of operating available designs.

It is necessary first to determine how the antenna impedances vary at the operating frequencies in order that the loading facilities may be properly used. The reactance of an antenna may be approximated from the theory of transmission lines in which uniformly distributed inductance and capacitance are assumed, resistance and insulator leakage being neglected.

Selecting a certain length of antenna and plotting its reactance variation with frequency, we obtain repeating cotangent curves. It may be seen that at certain frequencies the reactance becomes zero. Under these conditions, the antenna is "reso-

higher than their fundamental and odd harmonics, the converse is true, a capacitance in series with the antenna being necessary in order to balance the apparent antenna inductive reactance.

In most cases, except where 3/4 and 5/4 wave trailing wires are used for high frequencies, antenna operation will be around the fundamental frequency.

In general, it may be said that if antennas are operated so that their effective length is an appreciable percentage of the operating wavelength, they will have marked directive properties. This corresponds to operation near to and higher than the fundamental frequency. When antennas are operated at frequencies much lower than the fundamental, the ratio of radiation to total resistance is less favorable, but the directive properties are not nearly so evident. The fundamental frequency of an antenna depends mainly on its effective length including the ground lead. Fundamental frequencies in the range 2500-7000 kilocycles will be the most common with the usual types of fixed antennas, while fundamentals as low as 1500 kilocycles will be obtained with 200-foot trailing-wire antennas.

The antenna tuning equipment in the radio transmitter is designed to feed antennas at any frequency from 800 to 12,500 kilocycles. Over this band of frequencies it is necessary to feed antennas at above, and below their fundamental frequencies. Therefore, the circuit and circuit constants are so selected as to permit of both current and voltage feed. A rotating inductor and a tapped inductance provide the inductive reactance variation. A variable capacitor provides the variation in capacitive reactance and also serves as coupling impedance for voltage feed. Controls governing the variation in inductive or capacitive reactance are so arranged that inductance or capacitance are increased with increase in dial reading.

With the ANT. CIRCUIT SWITCH, N, on position 1, the radio transmitter works into a simple series resonant circuit, in which the high voltage built up across the antenna tuning capacitor is used to "voltage feed" the antenna. This circuit is generally used for high frequencies and fairly long fixed antennas. The antenna feed circuit is maintained at resonance by means of ANT. IND. TUNING, M, while the voltage fed to the antenna is varied by means of ANT. CAP. TUNING, O, and ANT. COUPLING SWITCH, D. Feed circuit resonance is indicated by the ANT. CURRENT meter. The current in the feed circuit is adjusted by control D and should not exceed 6 amperes. The step by step tuning procedure is as follows:

- (1) Set control O at some arbitrary scale reading.
- (2) Resonate circuit by means of control M for a maximum reading on ANT. CURRENT meter.
- (3) Adjust control D so that antenna ammeter

reads below 6 amperes.

- (4) Re-resonate circuit as in step (2).

Repeat the above procedure until the proper loading (200-220 ma on CW) is indicated on the plate ammeter. The lower the dial reading on control M and the lower the reading on the ANT. CURRENT meter, that it is possible to obtain at a given frequency, the more power will actually be delivered to a given antenna. The lower the reading on control M and the lower the ANT. CURRENT meter readings, the less the tuning circuit losses and thus more useful power is delivered to the antenna for radiation purposes.

With ANT. CIRCUIT SWITCH, N, on position 2, the radio transmitter works into a series resonant circuit where the antenna is "current fed." The antenna circuit is resonated by means of ANT. IND. TUNING, M, and ANT. CAP. TUNING, O, as indicated by the ANT. CURRENT meter. This circuit is used generally for operation near the fundamental frequency of the antenna.

With control N on position 3, the radio transmitter works into a series resonant circuit providing "current feed" and inductive loading. The antenna circuit is resonated by means of a continuously variable rotating inductor, control M. This circuit is used for operation below the fundamental frequency of the antenna.

With control N on position 4, the antenna circuit is identical with that obtained on position 3 except that an additional tapped inductance, controlled by ANT. IND. SWITCH, P, is added in series with the rotating inductor. This circuit is used when the operating frequency is relatively far below the fundamental frequency of the antenna.

It is recommended that the operator check the possible resonance of coil, item 1170, at operating frequencies above 4500 kilocycles. Although this coil is not connected in the antenna circuit, the inherent capacitive coupling may cause absorption of useful radio-frequency power. Absorption may be easily determined by placing control switch P at several points while watching the antenna current. Control P must not be allowed to remain at a point which indicates a decrease in antenna current. In general, it will be found that no difficulty will occur if the following points are used:

Transmitter Tuning Unit	"P" Switch Position
TU-7-B	2
TU-8-B	5
TU-9-B	5
TU-10-B	5

Par. 12

The antenna resonance is then made in the usual manner using controls M, N, and possibly O.

For operation in the frequency range of 150 to 800 kilocycles, the externally connected Antenna Tuning Unit BC-306-A is used. This unit contains the necessary inductive reactance to resonate specified antennas at frequencies well below their fundamental. The variation in inductive reactance is provided by the ANTENNA VARIOMETER SWITCH, control E, and the ANTENNA VARIOMETER, control F. The proper connections are described in the section on INSTALLATION. In general, it will be necessary to use Antenna Tuning Unit BC-306-A with Transmitter Tuning Unit TU-26-B, i.e., 200 kc to 500 kc.

Under some conditions it may be found that one coupling tap will not give sufficient loading while the next higher tap will give overloading of the radio transmitter. In this case use the higher coupling tap by slightly detuning the antenna circuit and keeping the P-A dial, control C, tuned to a minimum plate current until the normal transmitter loading of 210 to 220 milliamperes total plate current is obtained.

When operating into antennas of the trailing wire type it is advisable that the antenna circuit be resonated by adjusting its length as close as possible to the $\frac{1}{4}$ or $\frac{3}{4}$ wave point. This type of operation results in the removal of all transmitter tuning equipment from the antenna circuit and results in greatly increased antenna power. For this type of operation the antenna circuit switch, control N, should be placed on position 3 and the antenna loading coil, control M, set at zero. The antenna is then resonated by adjusting its length to a point that results in a maximum of antenna current. Coupling control D should be set so as to give normal plate loading and control C should be tuned for minimum plate current. The approximate length of wire required for various operating frequencies is given in part *e.* below.

d. Dynamotor Unit PE-73-C

Starting and stopping of the dynamotor unit is controlled by the OFF-ON switch at Radio Transmitter BC-375-E or remotely by a switch which may be wired to point 20 of Plug PL-64.

When operated at full-rated load continuously for $\frac{1}{2}$ hour the temperature rise of the dynamotor will not exceed 55 degrees Centigrade. However, if the dynamotor is operated for a greater length of time, even at lighter loads, without being allowed to cool off, its temperature will continue to increase and will ultimately reach values which are injurious to the insulation and may even burn out the windings. This also applies to the starting relay. If it is desired to

operate the dynamotor unit continuously at full load for a period greater than $\frac{1}{2}$ hour (such as for testing purposes in the laboratory) the end bells of the dynamotor and the cover of the relay-fuse box should first be removed. The dynamotor unit can then be operated at rated load continuously for any period of time without injurious heating. Care should be exercised to place guards around the dynamotor unit when operated in this manner so that operators cannot come in contact with exposed high voltages. When operated in conjunction with the radio transmitter the dynamotor unit operates at practically zero load unless the key or microphone switch is closed. Continuous operation under this condition will not result in over-heating although the radio transmitter should be turned off whenever possible between periods of transmission.

e. Reel RL-30-B

Braking, locking and winding operations are controlled from the crank on the reel. Normally the reel is in the locked position such that the wire will not unwind from the spool. Reeling-in is accomplished by rotating the crank in a clockwise direction, as indicated by the direction arrow "Wind" on the nameplate at the center of the reel spool. A ratchet mechanism on the spool prevents the wire from unreeling when the crank is released. By rotating the crank in a counter-clockwise direction the braking mechanism is released, thereby permitting the wire to be reeled out. Braking force decreases gradually as the handle is rotated through approximately the first 40 degrees of its motion. Beyond this point and up to the extreme limit of its motion the brake is completely released and the spool is free to spin. The speed of unwinding can be readily controlled by regulating the braking effect with the crank. A spring return on the crank automatically resets the brake to the normal or locked position when it is released.

Tuning the antenna by adjusting its length should be accomplished by allowing slightly more wire than is necessary to run from the reel and then reeling in slowly to obtain the proper length by observing the resonant condition. During the reeling out operation, care should be taken that all of the wire is not unreeled. The speed with which the reeling takes place would be sufficient to snap the wire if it reached its ultimate length, causing a loss of both the weight and wire.

WHEN UNREELING WIRE, NEVER ALLOW THE CRANK TO SNAP INTO THE LOCKING POSITION WHEN THE SPOOL IS ROTATING RAPIDLY. THE SUDDEN STOP WHICH WOULD RESULT MAY BREAK THE ANTENNA WIRE AND PLACE UNDUE STRESS ON THE REEL MECHANISM.

The following table gives the approximate antenna length for various frequencies as well as the approximate counter reading when 250 feet of Wire W-106 or Wire W-106-A is wound on the spool.

KC	1/4 Wave		3/4 Wave	
	Length (Ft)	Counter Reading	Length (Ft)	Counter Reading
2000	123	108		
3000	82	72		
4000	62	54		
5000	49	44	147	130
6000	41	36	123	108
7000	35	30	105	92
8000	31	28	93	82
9000	27	24	81	72
10,000	24	22	73	64

f. Operating Routine

The operating routine and type of transmission to be used will be governed by tactical requirements. The following recommendations are given, however, to assist in routine operation of equipments:

(1) Complete equipment operation should be checked before the start of any mission.

(2) Make certain that spare fuseholders are filled with good fuses, and that spare tubes (if carried) are in good condition.

(3) The transmission range of the equipment on CW is considerably greater than on VOICE. If distance, atmospheric noise, etc., make voice communication difficult, changing to TONE or CW will probably improve communication.

(4) In case of failure of one or two Tubes VT-4-C with no spares on hand, CW communication can be carried on by inserting the good tubes in the M-O and P-A sockets. CW operation can also be maintained when Tube VT-25 is removed, although no sidetone will be supplied in this event.

13. SUMMARY COVERING NORMAL OPERATION

Although the normal operation of this equipment is extremely simple after the correct installation has been made, it is well to study the proper sequence of various equipment procedure as summarized in the following paragraphs. It is assumed that the installation has been tested and all circuits are normal.

DO NOT CHANGE ANY SWITCHES WITH THE KEY OR MICROPHONE BUTTON DEPRESSED.

a. To start the equipment: snap the OFF-ON switch to ON. The dynamotor will start and the filaments will light. Unless the TONE and VOICE emissions have been adjusted, start up initially as given below. To control carrier depress the key.

b. To stop the equipment: open the key, then place the OFF-ON switch in OFF.

c. To change frequencies: select the required tuning unit and place in the radio transmitter. Place the MO dial, BAND SWITCH (if any), and the PA dial on the desired calibrated frequency as given on the calibration chart. Place the emission switch on CW, start up the radio transmitter and immediately check the PA dial for minimum plate current as indicated on the TOTAL PLATE CURRENT meter. Resonate the antenna circuit and load to a total plate current of 210 to 220 milliamperes with the P.A. dial resonated, i.e., always tuned to a minimum plate current. Proceed to key the carrier on CW or select the other types of emission as given below.

d. To select any available type of emission: start up the radio transmitter and tune for C.W. transmission first as given under c; then open the key and place the TONE-CW-VOICE switch on VOICE. Remove the tube shield and adjust the MOD. BIAS control after key is depressed until the total plate current reads 20 to 30 milliamperes above the CW value. Proceed to control carrier by microphone button and modulate by voice. Adjust the side tone signal to the desired level by means of the SIDETONE control located in the tube compartment. Adjust the voice level by the INPUT LEVEL control so the total plate current reaches 300 to 350 milliamperes on peaks of sustained voice.

e. For tone transmission: the operator must always adjust radio transmitter for VOICE, first. Then open the key, place the selector switch on TONE and proceed to key carrier as in CW.

f. To increase power output: go to a higher number on the ANTENNA COUPLING SWITCH, control D, at the same time keeping the P.A. dial, control C, and the antenna circuit in resonance. Power may be increased until a CW plate current of 220 ma. at 28 volts input is reached.

g. To decrease power: go to a lower number on ANTENNA COUPLING SWITCH, control D, at the same time keeping the P.A. dial, control C, and the antenna circuit in resonance.

h. It should be noted that the CW power output may be increased or decreased in the above manner from the value of plate current with the antenna circuit open to the full load rating of 220 milliamperes. However, the TONE and VOICE carrier power SHOULD NOT BE INCREASED OR

Par. 13

DECREASED. Unless the TONE and VOICE carriers are adjusted as given under steps *d.*, and *e.*, page 15, distortions will result. Also, the mis-adjustment may cause arc-overs which would damage the equipment.

i. **To reset to the calibration chart** after changing of the M-O tube, etc., start the radio transmitter on the highest frequency of the highest frequency tuning unit available. Warm up the radio transmitter on CW key locked for 25 to 30 minutes

The tube shield must be in place. Listen to the calibrated frequency on a suitable accurate heterodyne frequency meter and adjust the radio transmitter to zero beat by means of a screw driver inserted into the reset port on the left front of the radio transmitter panel. This should bring the radio transmitter back to calibration and all other frequencies should be within 0.05 per cent. For greater accuracies reset as above to the exact frequency desired.

SECTION III—FUNCTIONING OF PARTS

14. RADIO TRANSMITTER BC-375-E

In order that the theory of the principal component units may be better understood, the complete circuit has been broken down into several simplified circuits as shown on the functional diagrams which follow. Each basic circuit will be described in detail.

The radio-frequency circuit of the radio transmitter (see Figure 11) is of the conventional master-oscillator and power-amplifier type. The audio-frequency circuit consists of a speech amplifier and a Class B audio-frequency modulator which applies plate modulation to the Class C radio-frequency power amplifier. When operating on TONE, the speech amplifier is converted into an audio-frequency oscillator which supplies grid excitation at a frequency of approximately 1000 cycles to the modulator tubes.

Side tone for monitoring purposes is supplied during VOICE, TONE, and CW operation. CW

side tone is obtained by the use of the speech-amplifier tube as an audio oscillator.

The master-oscillator and power-amplifier radio-frequency circuits are built into the transmitter tuning units, of which 10 are required to cover the complete frequency range of the equipment.

The master-oscillator circuit is of the "series fed" type, either capacitively or inductively coupled to the power amplifier depending on the tuning unit in use. Assuming that Transmitter Tuning Unit TU-8-B (6200-7700 kc) is in place in the radio transmitter, the radio transmitter circuits will be discussed in detail (see Figure 11).

The tapped coil 801 and the capacitor 802 comprise the radio-frequency oscillating circuit. Both the coil and the capacitor are thermally compensated to reduce frequency variation due to changes in ambient temperature. Capacitor 802 is provided with a front of panel control (B) by means of which

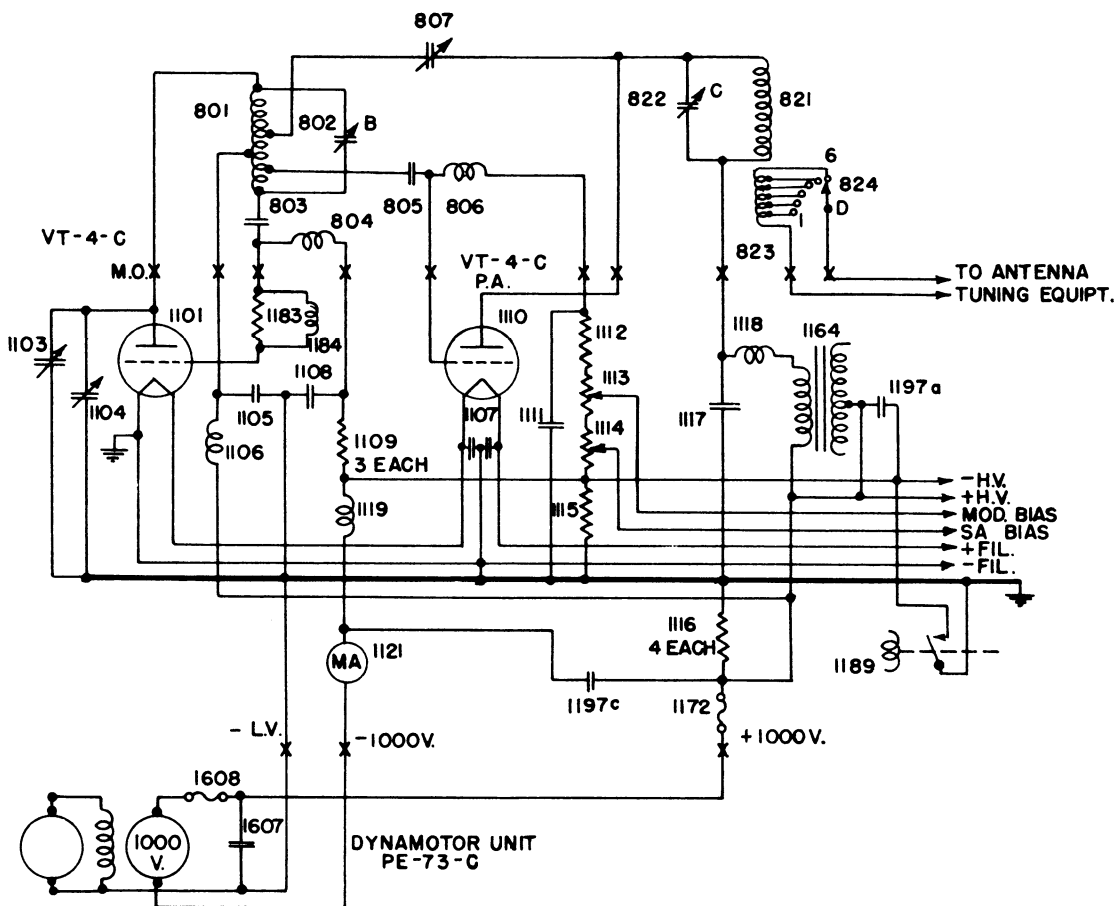

FIGURE 11. RADIO TRANSMITTER BC-375-E, FUNCTIONAL DIAGRAM OF RADIO-FREQUENCY AND HIGH-VOLTAGE CIRCUITS

Par. 14

the oscillator may be adjusted to the desired frequency. The center tap on the coil determines the master oscillator grid excitation. The coil is also tapped an equal number of turns on either side of this center tap. The lead connecting to capacitor 805 furnishes the power-amplifier P-A grid excitation. Master-oscillator M-O grid excitation is taken through capacitor 803, which blocks the plate voltage off the grid circuit. Resistor 1183 and choke 1184 in parallel are connected in series with the grid to prevent the generation of parasitic oscillations. Plate power for the m.o. is fed to the tuning unit through r-f choke 1106, which, with capacitor 1105 prevents rf from flowing into the power supply.

Resistor 1109 is the M-O grid leak which provides the required operating bias for the M-O tube from the rectified grid current. Capacitor 1108 is an r-f by-pass. Grid choke 804, in conjunction with resistor 1109, serves as the necessary direct current path from the grid to filament, maintaining a high impedance to the r-f grid excitation.

Capacitor 1104 is the calibration reset, by which the master-oscillator frequency can be adjusted to correspond to the calibration whenever the oscillator tube is changed. Capacitor 1103 provides thermal compensation for frequency drift normally caused by warmup and variation of ambient temperature of the oscillator tube.

The P-A tank circuit consists of coil 821 and variable capacitor 822. This capacitor has a panel control (C) for tuning the tank circuit to resonance. The P-A grid receives excitation through capacitor 805 from the M-O tank. Capacitor 805 also isolates the M-O plate voltage from the p-a grid. The p-a grid bias is obtained from the flow of rectified grid current through resistors 1112, 1113, and 1114. Choke 806 provides a low impedance path for the d-c grid current but a high impedance path at radio frequencies. Plate power for the PA is fed to the tuning unit through choke 1118, which with capacitor 1117, prevents r-f current from flowing into the power supply.

The neutralizing capacitor 807 forms a part of a bridge circuit including the power-amplifier grid-to-plate capacitance. Balancing of this circuit by means of capacitor 807 prevents any reaction of the power amplifier on its grid-input circuit, thus eliminating the possibility of self-oscillation of the amplifier. All radio transmitter tuning units are properly neutralized at the factory, and should never require adjustment in service unless the setting is accidentally disturbed. Instructions for making the neutralization adjustment are given in the "Service Notes" included in this instruction book.

The PA is inductively coupled to the antenna circuit by means of the tapped inductance 823; the taps on which are selected by a panel-controlled tap

switch 824 labeled ANT. COUPLING SWITCH, D. Sufficient variation in coupling is provided to allow operation into a wide range of antenna resistances.

The operation of the other types of transmitter tuning units is very similar to that described above, the only difference being in the methods by which the M-O and P-A circuits are tuned over their respective frequency bands. A detailed discussion of the circuits involved is included in the description of the transmitter tuning units later in these instructions.

The antenna tuning equipment and circuits provided in the radio transmitter are designed for operation with aircraft antennas at frequencies above 800 kilocycles. Rotating inductance 1167, control M; switch 824 labeled ANT. COUPLING SWITCH, D.

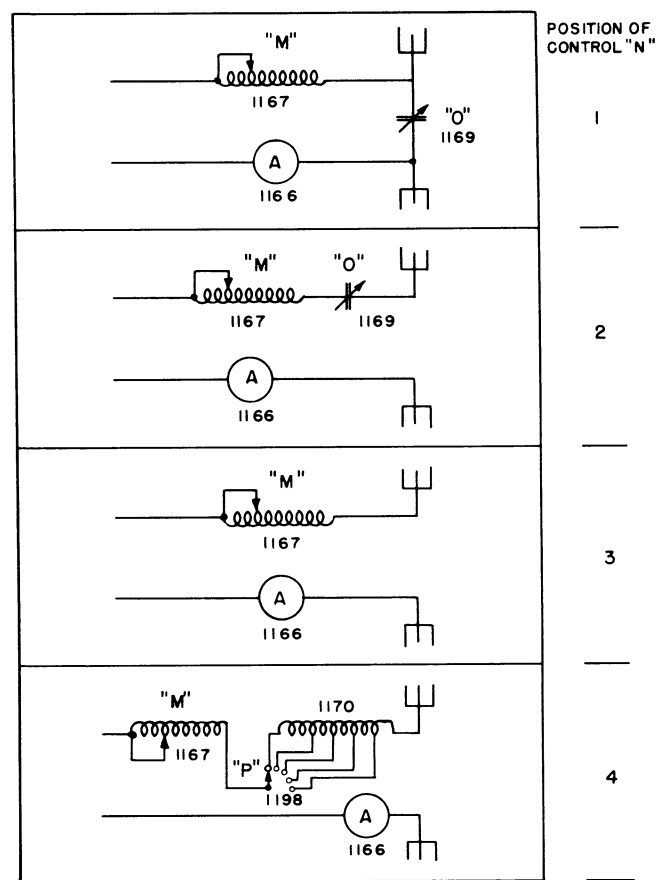

FIGURE 12. RADIO TRANSMITTER BC-375-E, FUNCTIONAL DIAGRAM OF ANTENNA TUNING CIRCUITS

inductance 1170; switch 1198, control P; variable capacitor 1169, control O; switch 1168, control N; and r-f ammeter 1166 comprise the antenna tuning equipment which is included in the radio transmitter unit. These parts may be connected to form four different antenna feed circuits corresponding to the four positions of the ANT. CIRCUIT SWITCH, control N, symbol 1168. Figure 12 shows four simple

line diagrams, marked (1) to (4) respectively, which indicate the type of antenna tuning circuit provided for the correspondingly numbered positions of control N. With this switch in position (1), the radio transmitter works into a simple series resonant circuit consisting of the tuning inductance 1167, control M, and the tuning capacitor 1169, control O; with the antenna ammeter indicating the current in the resonant circuit. The high voltage built up across the tuning capacitor is used to voltage feed the antenna. With control N in position (2), the tuning inductance and tuning capacitor are connected in series with the antenna permitting operation near the fundamental frequency of the antenna, i.e., where only small amounts of inductive or capacitive loading are required. Positions (3) and (4) provide inductive loading of the antenna with either tuning inductance 1167 alone or the tuning inductance and the tapped inductance 1170, controlled by switch 1198 control P, in the circuit. The antenna ammeter 1166 indicates actual resonance of the antenna circuit for positions (2), (3) and (4) of control N.

Modulation is applied to the plate supply of the power amplifier by means of the modulation transformer 1164. The modulator tubes, 1161 and 1162 are operated in a push-pull Class B circuit, in which they are biased nearly to cut off. This type of operation is characterized by high efficiency and output. The modulator power drain is negligible unless the tubes are being driven by the speech amplifier or

tone oscillator. Capacitor 1197a serves as an audio plate by-pass for the modulator plate supply. The modulator tubes receive excitation from the speech-amplifier tube 1154 through an interstage transformer 1199. The secondary of this transformer is loaded by resistors 1181 to reduce the effective load variation caused by the modulator grid current. Plate power for the speech amplifier is obtained from the positive high voltage through resistor 1156 which limits it to the proper value. Capacitor 1197b serves as an audio-frequency by-pass for this power source. Receiver side tone for monitoring the transmitted signal is provided by a tapped winding on the inter-stage transformer. Switch 1179 selects the proper tap on this transformer winding to give the desired sidetone level.

The TONE-CW-VOICE switch 1141 serves to select the desired type of transmission. It performs the following functions:

- a. It controls the modulator filaments.
- b. It controls the line compensating section of the filament resistor 1196. (See Figure 49.)
- c. It controls the tone oscillator feed-back circuit.
- d. It connects the microphone circuit to the input transformer 1149 for VOICE operation.

With switch 1141 in the TONE position, (Figure 13), capacitor 1142 feeds energy from the speech-amplifier plate to its grid in the proper phase relation to cause oscillation at an audio rate. The

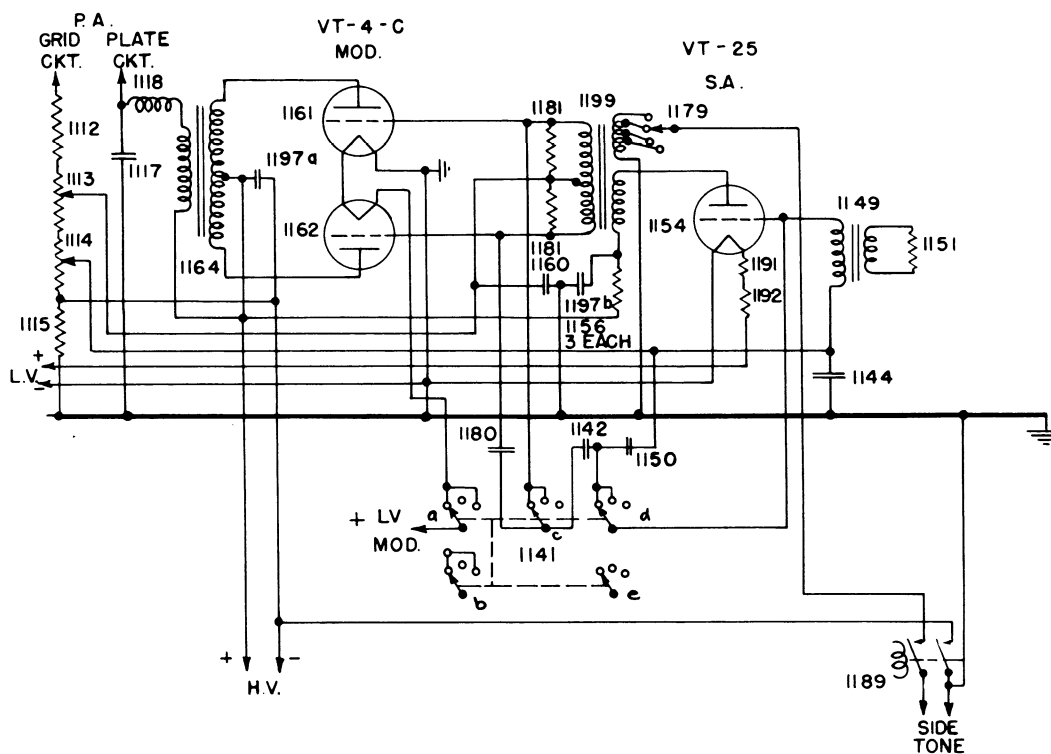

FIGURE 13. RADIO TRANSMITTER BC-375-E, FUNCTIONAL DIAGRAM OF AUDIO-FREQUENCY CIRCUITS TONE OPERATION

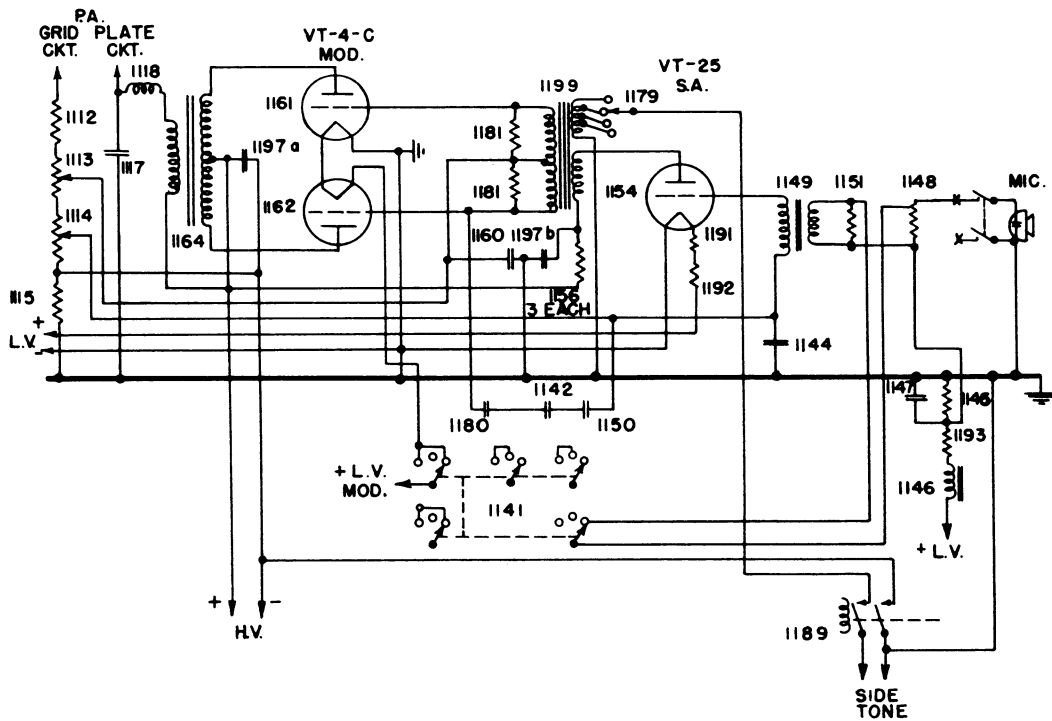

FIGURE 15. RADIO TRANSMITTER BC-375-E, FUNCTIONAL DIAGRAM OF AUDIO-FREQUENCY CIRCUITS VOICE OPERATION

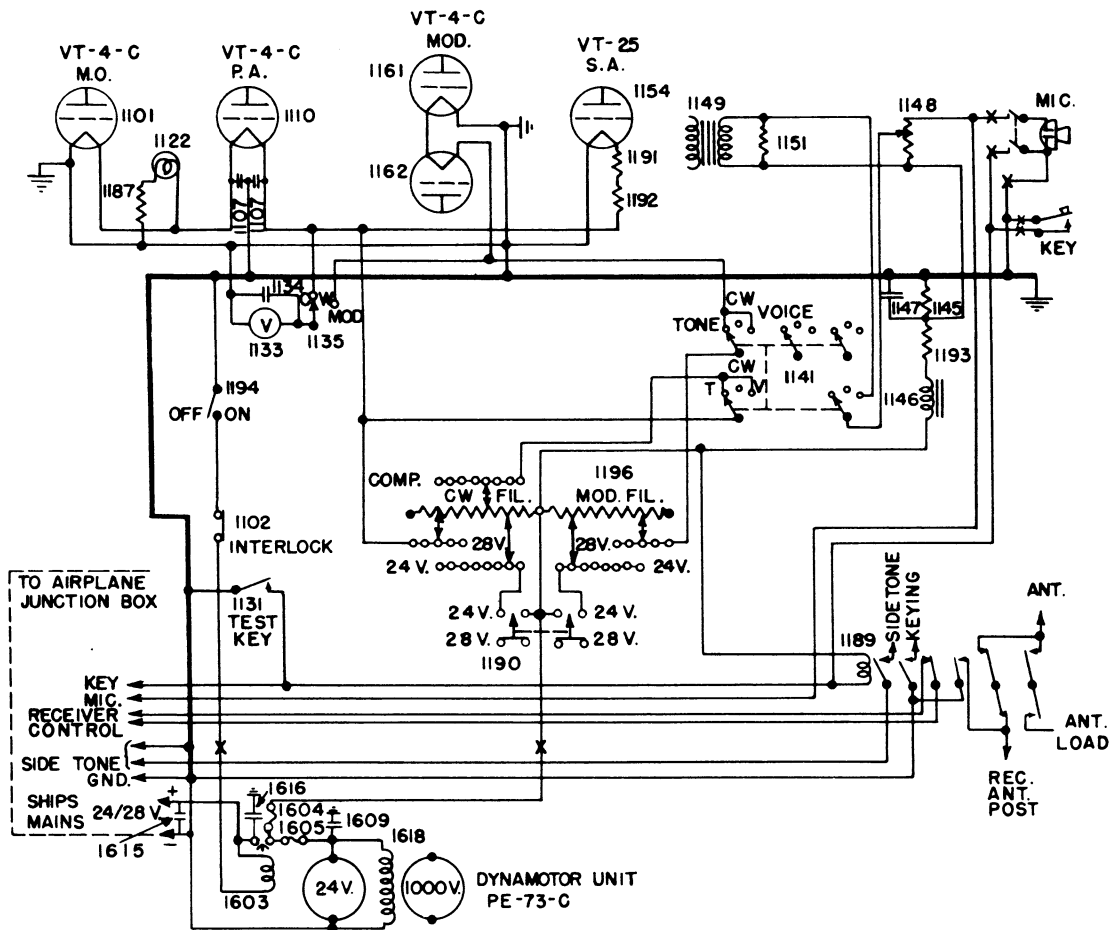

FIGURE 16. RADIO TRANSMITTER BC-375-E, FUNCTIONAL DIAGRAM OF LOW VOLTAGE AND CONTROL CIRCUITS

d. It opens the receiver screen grid or plate supply or operates a receiver control relay when the key is closed.

e. It keys the side-tone circuit.

Test key 1131, which may be used to close the keying relay while checking operation or making tuning adjustments, is located on the radio transmitter panel.

Control and power circuit connections are made through the sockets and jack provided on the left side of the radio transmitter unit. Low-voltage and power-control circuits enter the transmitter through Plug PL-61 inserted in socket 1126. The positive high-voltage connection enters this unit through Plug PL-59 in socket 1127. Interphone, side tone, and receiver keying connections to the junction box, if used, are made by means of Plug PL-64 in socket 1128. Jack 1129 is for microphone and key connections for locally controlled operation of the radio transmitter. (See Figure 49 for 1126, 1127, 1128, 1129, 1172, 1190, 1135, 1133, 1121, 1119.)

OFF-ON switch 1194 serves to close the dynamotor unit relay and thereby apply power to the radio transmitter. Interlock 1102 serves to remove power from the radio transmitter when the transmitter tuning unit is not in place. Indicator lamp 1122 shows when power is applied to the radio transmitter. It is connected in series with resistor 1187 across the filament supply.

Overload protection is provided by fuse 1172 (Fuse FU-12-A) which is located in the positive high-voltage lead. Radio-frequency choke 1119 is used for filtering in the negative high-voltage lead. Milliammeter 1121, in the same lead, measures total plate current. Capacitor 1197C serves as plate supply filter. (See Figure 50.)

Resistor 1196 is used to adjust the filament potentials to 10 volts as indicated by the white blocking on voltmeter 1133. The midtap of this resistor is connected to the power source. One side of the resistor is used for the adjustment of the fila-

ments of the tubes used for CW operation and the other side for the modulator tubes. Provision is made to short out a section of the CW filament resistor by means of switch 1141b to compensate for the increased line drop which occurs when the modulator filaments are lighted. This arrangement makes it unnecessary to readjust the voltages when changing from CW to TONE or VOICE. A portion of the resistor may be short-circuited by the 24 V./28 V. switch 1190 so that correct filament voltage may be applied both when the power-supply storage battery is being charged (terminal voltage approximately 28.0 volts) and when not being charged (terminal voltage 24 volts). Switch 1135 connects filament voltmeter 1133 to either the CW or MOD. filaments.

15. VACUUM TUBES

Tube VT-4-C is a triode with a directly heated thoriated filament, which provides large emission with low expenditure of filament energy. Connections for the grid, plate, and filament are brought through the tube base. This tube has a manufacturer's rating of 100 watts maximum plate dissipation. Characteristic curves of Tube VT-4-C are shown in Figure 17. The following table gives the constants of typical tubes as used in this radio transmitter.

Filament voltage.....	10 volts
Filament current.....	3.25 amperes
Plate current (max.)....	0.175 ampere
Amplification factor.....	12
Plate resistance.....	3400 ohms
Plate voltage.....	1000 volts

Note: Tube VT-4-C has a definitely specified limit to secondary emission and is therefore a better oscillator and amplifier than Tube VT-4-B.

Tube VT-25 is a triode with a directly heated filament. The grid, plate and filament leads are brought out through the tube base. This tube functions in this radio transmitter as a speech amplifier or audio oscillator. The following table gives the constants of typical tubes as used in this radio transmitter:

Filament voltage.....	7.5 volts
Filament current.....	1.25 amperes
Grid voltage.....	-35 volts
Plate current.....	0.019 ampere
Amplification factor.....	8
Plate resistance.....	5000 ohms
Plate voltage.....	425 volts

Characteristic curves of Tube VT-25 are shown in Figure 18.

For normal continuous-wave operation, the speech-amplifier, master-oscillator, and power-amplifier tubes are used. For VOICE and also TONE modulated continuous-wave operation, all five tubes are used. Separate filament resistors are employed

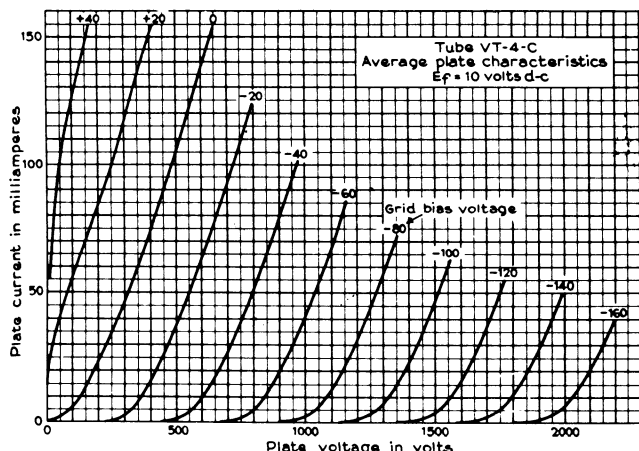

FIGURE 17. TUBE VT-4-C, CHARACTERISTIC CURVES

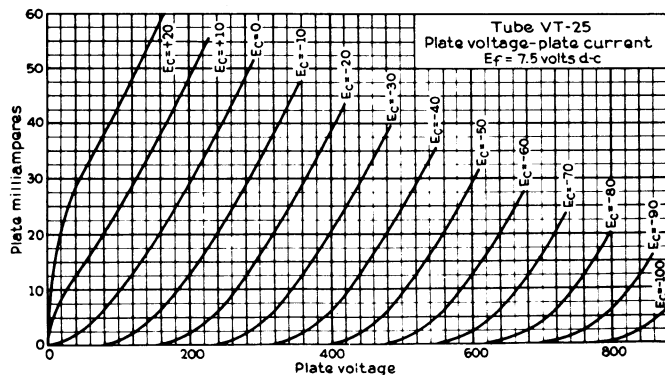

FIGURE 18. TUBE VT-25, CHARACTERISTIC CURVES

for the master-oscillator, power-amplifier and modulator tubes. This obviates the necessity of readjusting the filament voltage each time a change is made from CW to TONE or VOICE and vice versa.

16. TRANSMITTER TUNING UNITS

The circuit description of Transmitter Tuning Unit TU-8-B which was given in connection with the description of the radio transmitter, is applicable to Transmitter Tuning Units TU-7-B and TU-9-B. The circuit of the TU-10-B is practically the same as that of the TU-8-B, the M-O plate by-pass capacitor 1009 and plate choke 1010 being added. For a schematic diagram of all transmitter tuning units refer to Figure 52.

Transmitter Tuning Unit TU-6-B is very similar to TU-8-B. The same type of M-O circuit is used. However, the frequency range of this tuning unit is covered in two bands. Band change switches 602 and 622, control A, connect fixed capacitors 603 and 623 in the M-O and P-A circuits respectively to cover the low-frequency end of the band. Capacitor 603 in the M-O circuit is provided with a thermo-metal compensator 613 to provide the required frequency stability. Resistor 614 is the P-A grid parasitic resistor.

The frequency range of Transmitter Tuning Unit TU-5-B is covered by four frequency bands controlled by switches 502 and 522, control A. The type of circuit and thermal frequency compensation is the same as that in the units previously described. Resistor 517 is the p-a grid parasitic resistor.

Transmitter Tuning Unit TU-26-B uses inductive tuning. The tapped variometer 2601 (see Figure 59), with the voltage dividing network capacitors 2610, 2611, 2612, 2613, 2614, and 2615, comprises the basic M-O tank. The band change switch 2607, control A, selects the proper taps on the variometer and connects the additional tank capacitors 2608 and 2609 into the circuit so as to properly cover the frequency range. The thermal compensators 2605, 2619, and 2620 consist of small capacitors with a

special ceramic dielectric designed to provide the required thermal frequency stability. 2602 and 2603 are the M-O plate and grid chokes respectively. 2604 is the M-O grid blocking capacitor. Resistor 2617 is located in the M-O grid circuit to suppress parasitic oscillations. Excitation for the P-A is obtained across capacitor 2614 through blocking capacitor 2618. 2606 is the P-A grid choke. The P-A tank is tuned by means of the tapped variometer 2621 and fixed capacitors 2623, 2624, 2625 and 2626. Switch 2622, ganged with 2607, to control A, selects the proper variometer tap and capacitor arrangement for the desired frequency. The voltage required to neutralize the power amplifier is obtained across capacitor 2613 through neutralizing capacitor 2616. Coil 2627 and switch 2628, control D, provide the necessary coupling to the antenna circuit.

To obtain the high degree of frequency stability required in this equipment, the blocking and coupling capacitors used in all tuning units are of an improved high stability type. Relative to Transmitter Tuning Units TU-5-B to TU-10-B inclusive, the master-oscillator tank coils are tension wound and the variable tank capacitors are specially constructed of invar to provide a lower and more uniform temperature coefficient.

17. ANTENNA TUNING UNIT BC-306-A

Antenna Tuning Unit BC-306-A, Figure 19, consists of tapped variometer 1502 which furnishes inductive loading reactance for series resonating the highly capacitive antennas used with Transmitter Tuning Unit TU-26-B, i.e., 200 kc to 500 kc. The varying amounts of reactance used are adjusted by the variable rotor control F, and the tap switch 1501,

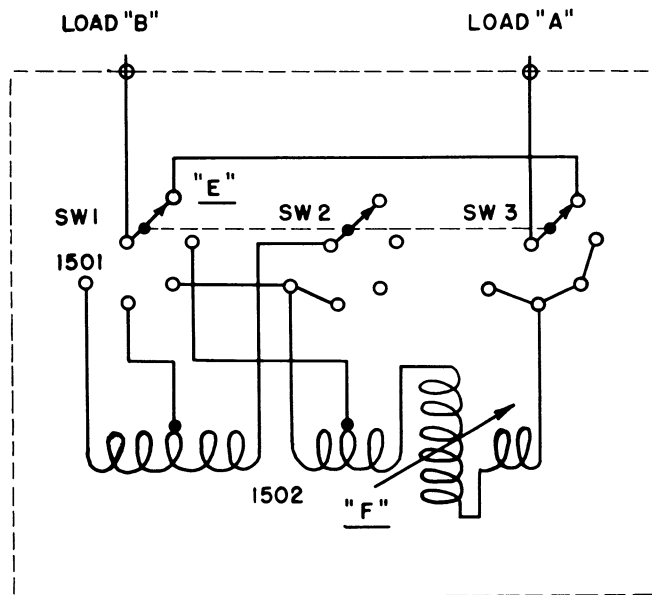

FIGURE 19. ANTENNA TUNING UNIT BC-306-A, SCHEMATIC DIAGRAM

Par. 18

control E. It will be noted that the tap switch is made up of three parts. This construction permits a total disconnection of the tuning unit when control E is on tap 1. It also permits the efficient use of a small portion of the inductance on taps 2 and 3 without excessive loss from a large unused section being connected to the circuit.

18. DYNAMOTOR UNIT PE-73-C

The function of Dynamotor Unit PE-73-C (Figure 20) is to provide high voltage for the vacuum tube plates. The dynamotor unit derives its power from a 24/28-volt d-c source, such as a storage battery. The complete dynamotor unit consists of the dynamotor proper together with its fuses, starting relay, terminal board, by-pass capacitors, and sockets for connection to the radio transmitter. Spare fuse links, a spare high-voltage fuse, and a small hexagon servicing wrench are attached to the cover of the fuse box.

The dynamotor unit is started by ON-OFF switch 1194 on the front panel of the radio transmitter. This switch energizes starting relay 1610 which closes and applies the input voltage to the motor end of dynamotor 1618 through the protecting fuse 1605. This also permits current to flow through fuse 1604 to the transmitter filament and control circuits. Capacitors 1607, 1609, 1613, 1614, 1615, and 1616 by-pass to ground any radio-frequency interference which may be generated by the dynamotor brushes. Socket SO-39 and Socket SO-41 contain all high- and low-voltage leads which are to be connected to the radio transmitter. Fuse FU-22 (1605), which protects the low-voltage circuits from overloads is of a type known as "Superlag," and is designed to permit heavy starting surges of short duration, though prolonged overload current will cause the fuse to open.

Protection of the high-voltage circuit and of the dynamotor winding is obtained by Fuse FU-18-A (1608), which is of the flame-proof type.

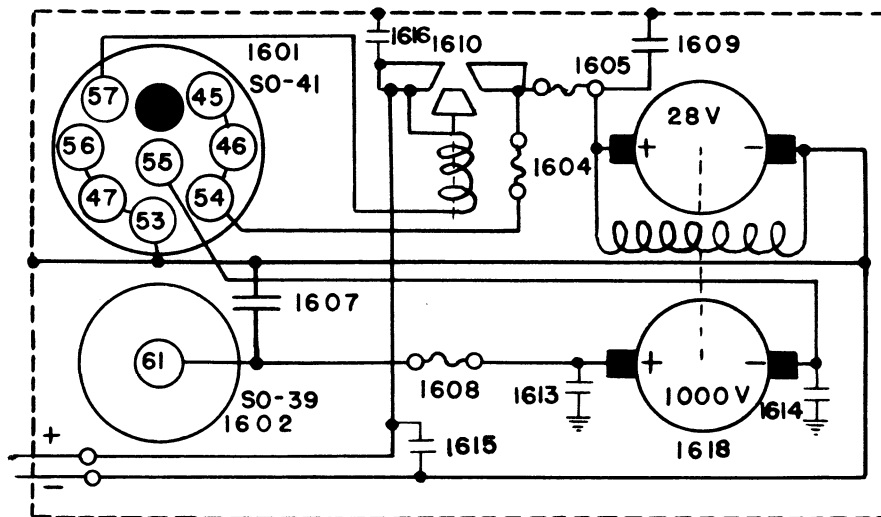

FIGURE 20. DYNAMOTOR UNIT PE-73-C, SCHEMATIC DIAGRAM

SECTION IV—MAINTENANCE

19. INSPECTION

The inspection of installed radio equipment is covered by various Air Corps Circulars and Technical Orders. Instructions contained in those circulars and Technical Orders shall govern over any instructions contained herein. The following instructions are meant to cover, in detail, the points of inspection which are applicable to this particular equipment. The times at which the various inspections are to be made shall be governed by the applicable Circulars and Technical Orders.

a. Daily Operating Inspection

In order that a quick check on the condition of the transmitting equipment may be made prior to each day's flight, the following procedure is recommended.

(1) Determine that the storage battery is at the proper gravity and that the charging generator and regulator are adjusted so as to keep the battery fully charged.

(2) Make certain that all safety wiring is in place, that all mounting brackets and supports are rigidly fastened, and that all nuts and machine screws are supplied with lockwashers and are tight.

(3) Determine that no cords have broken shielding and that all grounding and bonding is in place.

(4) Inspect plugs for proper fit and plug sockets for compressed pin springs. Compressed pin springs, which have taken a permanent set, can be restored by a light hammer blow on the end of the pin.

(5) Make certain that all fuses are held tightly in their clips. A loosely held fuse should be removed and the clips bent with the fingers until they grip the fuse tightly. The clips and fuse ends should be kept clean and the contact surfaces bright.

(6) Antennas should be inspected for broken or frayed leads, and insulators should be wiped clean. Be sure that antenna leads have not been bent close to metal frameworks where high antenna voltages might cause spark-overs.

(7) Inspect keys and microphones for broken cords and deformed plugs.

(8) With the airplane outdoors, check the operation on CW, TONE, and VOICE. Check the setting of all controls against the calibration charts and, if possible, check the operating frequency by means of an accurate frequency meter. Check the quality of voice transmission by listening in at some suitable receiving station.

(9) If the operation of the radio transmitter indicates that any vacuum tube is defective, that tube should be replaced by a tube that is known to be good. If either the M-O or P-A tube is replaced the operating frequency should be rechecked

and the M-O calibration reset as described in paragraph 12b6.

b. Maintenance Inspection

At the time specified for this type of inspection, the following inspection and cleaning should be given.

(1) Clean accumulated dust and dirt from all units. Use an air hose or bellows, paying particular attention to the loading coil, item 1170, in the antenna compartment of the radio transmitter. At this time inspect the rotating coil in this compartment. The winding should be thoroughly cleaned with naphtha or petroleum spirits and a clean cloth.

(2) Inspect dynamotor brushes for length. Detailed instructions on care of brushes are given herein.

(3) Inspect both dynamotor commutators for cleanliness and excessive wear. Information on care of commutators is given in these instructions.

(4) Rotate the dynamotor armature by hand to make certain it turns freely and is not rubbing against the field poles or leads. When all four brushes are removed, the armature should spin freely on its bearings. Refer to detailed information on dynamotor bearings.

c. Yearly Inspection and Overhaul

After each year of service it is desirable that the entire radio equipment be sent to the Signal Corps Radio Section of the proper Air Depot for complete overhaul as follows:

(1) Dynamotor Unit PE-73-C should be serviced as described in paragraphs 20 and 21h.

(2) A very complete inspection of all equipment should be made to determine if all assemblies and connections are tight and properly cleaned.

(3) The contacts of all switches (except enclosed switches) should be cleaned with naphtha or petroleum spirits and a light film of white vaseline applied to the rubbing surfaces.

(4) All working parts of the equipment should be lubricated as described in paragraph 20.

(5) The electrical performance of the complete equipment should be very thoroughly checked. These checks should include voltage, current and power measurements and an over-all test of modulation.

(6) Inspect the wire horn gap on the back of the output terminal board. The setting on this gap for all radio transmitters using frequencies below 1500 kilocycles is 0.171 inch. Adjustment should be made with the fingers in order that the wire remain smooth and free from nicks.

20. LUBRICATION

a. Lubricants

The lubrication of the equipment involves the use of four lubricants and one cleaning solvent. These are:

(1) Light Oil: A high-grade, low pour test, mineral oil with viscosity rating SAE10.

(2) Light Oil: A high-grade, low pour test, mineral oil with viscosity rating SAE20.

(3) Light Oil: A high-grade instrument oil such as Type D6B5 as manufactured by the General Electric Company.

(4) "Oil Dag" (graphite in oil): Manufactured by Acheson Colloids Corp., Port Huron, Mich.

(5) Grease: Use only high-temperature ball-bearing grease such as Grade 295, Air Corps Specification No. 3560. "Lubrico M-21" as supplied by the Master Lubricants Co., Philadelphia, Pa., or N. Y. & N. J. Lubricant "No. 1572 Special" are recommended for use where the temperature does not drop lower than -31° F. Do not use unauthorized greases as they melt out at high temperatures or oxidize rapidly and become gummy when packed in the bearings.

(6) Cleaning Solvent: Naphtha or petroleum spirits are strongly recommended.

b. Periodic Lubrication Routine

(1) Dynamotor Unit PE-73-C

Two types of bearing brackets will be found on dynamotor units supplied on Order No. 16-WFSC PD-42. The first type, which is a sand casting, has an oil hole, with screw plug, over each bearing.

The second type, which is a die casting, does not have an oil hole. As noted in the lubrication instructions which follow, the bearing in this bracket requires less attention than that of the other type.

Under normal operating conditions, the dynamotor unit bearings should be lubricated in accordance with the following schedule:

(a) After every 1000 hours of operation, or at intervals of six months, insert three drops of SAE20 oil into the small oil hole which is provided in the top of each bearing housing and is closed by a screw plug. Start the threads on this plug by hand in order not to cross thread the screw plug.

(b) After every 5000 hours of operation, or at intervals of one year, add approximately 0.05 cu. in. ($\frac{3}{8}$ in. cube) of ball bearing grease to each bearing through the oil hole mentioned above.

Note: Do not add more oil or grease than specified above, since the excess lubricant will tend to work out of the bearing housing onto the commutators and brushes where it will cause trouble if not removed. Excess grease in the bearing will have a tendency to churn and may cause the bearing to overheat. Always make

certain that the lubricants used are clean and that no dirt, moisture or foreign matter enters the oil hole when adding the lubricant. Tighten screw plugs securely into the oil holes as soon as lubricant is added.

(c) After every 10,000 hours of operation, or at least every two years, remove the armature from the dynamotor unit, thoroughly clean the bearings and bearing housings with naphtha or petroleum spirits, and repack each ball bearing level full of approved ball bearing grease. See procedure for disassembly and cleaning of bearings.

(d) For dynamotor units without oil holes, only the procedure given under paragraph (c) is applicable.

(2) Reel RL-30-B. The construction of this unit is such that it will require very little attention. The following lubrication routine is recommended to obtain the best operating results:

(a) After every 20 hours of flying time apply six drops of SAE10 oil at the oil hole indicated on the hub nameplate.

(b) After every 1000 hours of flying time or every six months, whichever comes first, do as follows:

1 Remove the three fillister head screws which hold the crank handle lever to the hub and remove the crank.

2 Remove the small cotter pin and castle nut on the end of the reel shaft.

3 Remove reel spool and hub from the shaft.

4 Clean the accumulated dirt from reel shaft and the parts in the mounting base.

Examine the exterior parts of the reel hub and clean off all dirt.

5 Lubricate these points using SAE10 oil:
Counter gear shaft bearing—1 drop.
Main shaft—several drops along the bearing surface.

Rear ball bearing on hub adjacent to ratchet teeth—5 drops.

Front thrust bearing around the edge of the retaining nut at the front end of the hub—5 drops.

Front ball bearing around the gap between the outside of the hub and the edge of the piece into which the three screws from the crank handle lever are threaded—5 drops.

6 Reassemble the reel as follows:

Place the reel spool and hub on the shaft. Give the spool a slight spin clockwise until the ratchet engages the pawls.

Replace the castle nut with the fingers, run it down until snug and then back it off until the hub runs free (at least $\frac{1}{6}$ of a turn). Replace the cotter pin.

Assemble the crank handle and tighten the three fillister head screws.

This completes the operation of servicing the reel.

c. Miscellaneous Lubrication

The following miscellaneous lubrication instructions should be followed in connection with the maintenance of other units of the transmitting equipment. Places to oil and grease are listed. Do this after every 500 hours of service or at least after every 1000 hours. Do it oftener if dirt accumulation is excessive. Clean parts as required.

(1) Oil (General Electric Type D6B5)—Ball bearings in antenna switching relay of radio transmitter unit.

(2) Oil SAE20—Switch shafts in radio transmitter, transmitter tuning units and antenna tuning unit. Vernier mechanisms in radio transmitter, transmitter tuning unit and antenna tuning unit. Variable capacitor shafts in radio transmitter and transmitter tuning units.

(3) Grease—Contacts of switches, and switch positioning devices in radio transmitter, transmitter tuning unit and antenna tuning unit.

(4) NEVER lubricate the contact roller or the contact roller shaft of the rotating antenna inductor. These parts should run DRY and should always be kept spotlessly clean. Naphtha or petroleum spirits should be used to clean these parts.

(5) Graphite in Oil—In the transmitter tuning units, apply "Oil Dag" to the bearings and surfaces of the worm and worm gear of the master-oscillator tuning units.

21. SERVICE NOTES

In the servicing and locating of faults in the radio transmitter and associated equipment, it is necessary to remove various shields and covers to make the circuits accessible. Great care must be taken in testing with shields removed, because a great many points of high voltage are thus exposed. Whenever such testing is necessary, the proper procedure is to remove all power from the equipment, make the necessary circuit changes of meter connections and then apply power, keeping clear of all meters which are connected in the "high" sides of circuits where there may exist an appreciable voltage to ground.

ALWAYS REMEMBER THAT WHEN THE DYNAMOTOR IS RUNNING AND THE TRANSMITTING KEY IS OPEN, HIGH VOLTAGE IS PRESENT IN THE RADIO TRANSMITTER EVEN THOUGH THERE IS NO PLATE AMMETER READING.

In checking low voltage and filament circuits the single conductor cord with Plug PL-59 should be

disconnected from the radio transmitter, thus removing the high-voltage supply.

The following information is supplied to aid in servicing the equipment and locating faults:

a. Voltage Readings: (Use the high resistance Weston Voltohmmeter of Test Set I-56-A.)

(1) Low-voltage input of 24 to 28 volts, depending on the power-supply voltage, should be obtained from terminal 45 of Socket SO-41 to ground.

(2) Speech-amplifier plate voltage of approximately 425 volts should be obtained at the plate connection of the speech-amplifier tube when the radio transmitter is on VOICE.

It is recommended that a tube socket adapter be used which will allow not only readings of voltage but also all currents for Tube VT-25.

(3) Modulator bias voltage of 72 to 75 should be obtained across capacitor 1160, the positive side being at ground potential. Selector switch should be on VOICE.

(4) Speech-amplifier bias voltage of 35 to 40 should be obtained across capacitor 1144, the positive side being at ground potential. Emission selector switch should be on VOICE.

(5) Plate voltage of 1000 to 1100 volts should be obtained between terminal 61 of Socket SO-39 and ground.

(6) Keying voltage of approximately 200 volts will be obtained across resistor 1115 when keying relay 1189 is open.

(7) Using the output meter of Test Set I-56-A, the side-tone voltage may be measured across a suitable load resistor. With the SIDE TONE switch in position (1) and a load of 150 ohms, the voltage should be approximately 2.5 volts. In position (2) with the same load, the voltage should be between 4.5 and 7.5 volts. Using a 2000-ohm load, position (3) should read approximately 10 volts and position (4) should read 17.5 to 30 volts. It will generally be found that the CW position will give a higher voltage than the VOICE or TONE positions.

(8) Microphone-supply voltage of 4.5 to 5.3 volts d-c should be obtained across resistor 1145. For this test, the microphone should be in the circuit.

b. Current Readings

(1) Speech-amplifier plate current should be from 17 to 22 milliamperes. Adjustment of the bias voltage to obtain this value is accomplished by potentiometer 1114 which is accessible in the tube compartment.

(2) Modulator plate current may be determined by observing the increase in total plate

Par. 21

current reading when changing from CW to VOICE and impressing normal modulation. The modulator plate current should average 100 to 160 milliamperes for sustained tones. A greater or smaller value than this indicates that a readjustment of the input level should be made.

(3) Master-oscillator plate current can be determined on the TOTAL PL. CURRENT meter by removing both wire 43 (red) on filter capacitor 1197a as in the procedure for neutralization of the power amplifier (see paragraph 21g), and the speech amplifier tube, and placing the TONE-CW-VOICE switch on CW. The current indicated should be from 30 to 75 milliamperes, depending on the transmitter tuning unit in use.

(4) Power-amplifier plate current may be determined by subtracting from the total plate current on CW the currents drawn by the master oscillator and speech amplifier. Its value should be from 100 to 150 milliamperes at full load.

(5) Master-oscillator grid current can be determined by connecting a d-c milliammeter in series with resistor 1109. Correct value should

be from 30 to 50 milliamperes.

(6) Power-amplifier grid current can be determined by inserting a d-c milliammeter in series with resistor 1112. Correct value is from 15 to 25 milliamperes.

Various other circuits may be checked by referring to the schematic diagram Figure 49. Then by referring to the various unit connection diagrams, the location of the various circuit elements may be ascertained.

c. Typical Dynamotor Performance: The dynamotor should operate approximately as follows on a load test:

Input		Output	
Volts	* Amperes	Volts	Milli-amperes
28.0	5-8	1140-1160	0
28.0	14-17	1070-1090	220
28.0	20-22.5	1025-1050	350

* The input current above includes that taken by the starting relay.

d. Location of Faults: If the operation of the equipment falls below normal, several simple checks listed below may be readily investigated.

Symptoms	Probable Causes
No filament voltage	Relay 1610 not operating when OFF-ON switch is placed in ON position. Fuse 1604 open. Normal fuse resistance is not over one ohm. Switch 1135 must be in proper position corresponding to CW or MOD.
Low filament voltage	Resistor 1196 not adjusted properly. High resistance leads between dynamotor unit and transmitter. There should be at least 20 volts at terminals 47 and 54 of Socket SO-41, item 1126. Low input voltage to dynamotor.
Key relay inactive	Key jack not making good contact. Cord open. Energizing coil open.
No plate current	Fuse 1608 in dynamotor unit or fuse 1172 in transmitter open. Normal fuse resistance not over 3 ohms. Filaments not lighted. Key relay inactive.
Excessive plate current (No antenna load—CW)	P-A TUNING control C not in tune. M-O tube inoperative.
Excessive plate current (Antenna loaded—CW)	Coupling tap D on too high a number. On some tuning units, or with low resistances, it may be necessary to detune the antenna to secure 220 ma on CW. <i>Always maintain the P-A TUNING control C in tune.</i>
No antenna current	Antenna circuit open. Antenna not properly tuned. Link not in terminal board A to B.
No side tone (TONE—CW)	Tube VT-25 defective. S.A. BIAS control not set properly. The correct setting will usually be found between 6.0 and 7.5 on the dial.
No or low side tone (VOICE)	Same as above. Adjustment may be too low. Operator may need to adjust side-tone level to a higher number than for TONE or CW, especially if a low-level voice is used.

Troubles of a more complex nature will require analysis with Test Set I-56-A or equivalent. Methods of procedure for some of the more probable troubles are listed below. Operating personnel are warned to use extreme caution to avoid accidental contact with high-voltage parts while making the following tests. ALWAYS REMEMBER THAT WHEN THE DYNAMOTOR IS RUNNING AND THE TRANSMITTING KEY IS OPEN, HIGH VOLTAGE IS PRESENT IN THE RADIO TRANSMITTER EVEN THOUGH THERE IS NO PLATE AMMETER READING.

Fault	Test Procedure
Dynamotor won't run	<p>Check to see if tuning unit is firmly in place and interlock 1102 is closed.</p> <p>Test Fuse FU-22 (1605), and check voltage (24 or 28) at line input terminals. Remove end bells and disconnect input voltage. Then rotate armature. If armature does not rotate freely, follow instructions for dynamotor under LUBRICATION.</p> <p>If the dynamotor armature turns freely, connect input voltage again and short pin No. 57 of Socket SO-41 to ground. If machine now runs, look for open lead in cord to transmitter.</p> <p>If dynamotor does not run when pin No. 57 of Socket SO-41 is grounded, listen for click of starting relay 1610 and check voltage across its terminals. 24 to 28 volts should exist with pin No. 57 grounded.</p> <p>If dynamotor starts to rotate then stops as Fuse FU-22 blows, replace the single link in Fuse FU-22 with two Fuse Link M-168 in parallel. The instantaneous line current sometimes overheats the fuse on input lines of good regulation while normal running currents would be satisfactory.</p> <p>With the input power off, the large relay terminals may be shorted and the dynamotor circuits checked for continuity to the brushes. CAUTION: Replace all dynamotor brushes in the same holder with the marking up, exactly as removed. The brushes have been accurately fitted and run-in exactly as shipped.</p> <p>A very slight difference between brush holders will cut the effective brush contact area considerably. This will lower the dynamotor efficiency.</p> <p>If after these tests, the dynamotor will not operate, first try a substitute dynamotor if available, then ship the defective unit to the Signal Corps Radio Section of an Air Depot for servicing.</p>
P-A TUNING control C has no effect on total plate current	<p>First, reduce the ANT. COUPLING control D to a minimum; switch position 1. If this has no effect, examine and replace the M-O tube. Be sure radio transmitter is on the CW position as this entire fault may be caused by an improperly tuned power-amplifier tube and mis-adjusted modulator tubes when operating in the VOICE position. Measure the voltage from the junction of 1111 and 1112 to ground. If the master oscillator is functioning properly, this voltage should be approximately 200 volts d-c key down. Should this voltage be near zero, check the voltages on the master-oscillator tube and continuity of the P-A grid circuits.</p> <p>The master-oscillator tube may be checked for operation by holding a neon bulb in the hand in contact with the glass of the master-oscillator tube. If the M-O tube is oscillating, the neon tube will glow. By substitution of tuning units, one may determine if the trouble is peculiar to the tuning unit or to the radio transmitter.</p>

Fault (Cont'd)

Test Procedure (Cont'd)

If the trouble is in the tuning unit, remove the cover and check continuity of all circuits. Look for chips and shorted turns on the tank coils, dirty capacitors and open choke coils. Capacitor plates may be effectively cleaned with pipe cleaners. If the unit is to be blown out, be sure to use clean dry air.

Radio transmitter sparks over at high altitudes

Read instructions on high altitude operation under section II, EMPLOYMENT. If the radio transmitter does not meet the altitude operation stated in the above section, the radio transmitter must be thoroughly checked over. Tuning units must be blown clean and capacitors wiped plate by plate with a pipe cleaner. The master-oscillator and power-amplifier tubes should be changed. The air gap on the back of the output terminal board must be set for 0.171 inch. Wipe the key relay posts and output terminal board with a clean dry lintless cloth. Inspect antenna compartment for clearances of the wiring. All wires should be spaced clear from ground. Compare the faulty transmitter antenna compartment with a normal unit.

No modulation on VOICE

Check the TONE-CW-VOICE selector switch for position. Substitute another Tube VT-25. Check that the CW carrier is properly adjusted. Check voice increase of 20 to 35 ma in total plate current over the CW value of 220 ma. If total plate current cannot be adjusted for this increase, change modulator tubes. Check continuity of circuits with all power off.

Remove high voltage Plug PL-59 from radio transmitter and place the high resistance voltmeter of Test Set I-56-A across terminals 3 and 4 of transformer 1149. Speak into the microphone with the filaments lighted. The a-c voltage on a loud signal should be approximately 1 to 2 volts. This is a check of the input circuits. If no voltage is read check continuity of circuits as given in the resistance chart.

No modulation on TONE

If the CW and VOICE operation is normal, one can assume that the tubes are satisfactory and the trouble lies in the fact that the speech-amplifier tube fails to oscillate. If this is the case, no side tone will be heard on pin No. 33 of Socket SO-44 (1128) either on the CW or TONE positions. Check the S.A. BIAS control. This will usually be between 6 and 7.5 on the dial. If still no tone modulation exists, remove the dynamotor cables and check continuity of circuits, especially switch 1141.

Distortion on VOICE

Checking INPUT LEVEL control. The setting of this control depends on the microphone and the voice level of the operator. It will usually be found that a setting of 7 to 8 on the dial allows the total plate current to swing to 350 milliamperes on peaks of voice level, using the standard Signal Corps microphones.

If the VOICE MODULATOR BIAS has been properly adjusted and distortion is still present, set the INPUT LEVEL so that peaks of modulation are limited as shown by the total plate current swinging upward to a maximum of 300 milliamperes. If either modulator Tube VT-4-C, or the speech amplifier Tube VT-25, are defective, distortion will exist. Recheck CW first, then VOICE adjustments to see if properly adjusted.

e. Typical Readings: The following values of voltages, currents, and settings represent average data and may vary as much as ten per cent for individual equipments. CW output is measured into a phantom antenna whose constants are similar to those in actual practice. The antenna current was measured by an external ammeter directly in series with the phantom resistor. The transmitter ammeter at the time gave current readings slightly higher because of the inherent stray capacitance in the radio transmitter.

RADIO-FREQUENCY POWER OUTPUT

Transmitter Tuning Unit	F _{kc}	C _a (1)	A	B	C	D	E (2)	F (2)	M	N	O	P	Total I _p MA	Watts Out. (3)	Ant. Current
TU-5-B	1500	200	1	1335	43	3	12.5	4	...	2	205	45.0	3.0
TU-5-B	3000	200	4	2098	80	2	21.5	3	220	65.0	3.6
TU-6-B	3000	150	1	976	41	3	21.8	3	220	60.0	3.46
TU-6-B	4500	150	2	2162	86	2	12.5	3	220	55.0	3.32
TU-7-B	4500	100	...	419	22	2	14.5	3	...	2	220	60.0	3.46
TU-7-B	6200	100	...	2180	95	3	5.4	3	...	2	220	75.0	3.87
TU-8-B	6200	100	...	698	20	2	7.8	3	...	5	220	70.0	3.74
TU-8-B	7700	100	...	2163	84	2	4.5	3	...	5	220	75.0	3.87
TU-9-B	7700	100	...	580	23	3	4.8	3	...	5	220	70.0	3.71
TU-9-B	10000	100	...	2169	82	2	1.0	3	...	5	220	75.0	3.87
TU-10-B	10000	100	...	468	18	2	4.8	2	100	5	220	65.0	3.60
TU-10-B	12500	100	...	2095	76	2	1.0	2	100	5	220	75.0	3.87
TU-26-B	200	600	1	621	32	4	4	31	0	3	220	30.0	2.40
TU-26-B	500	600	3	2266	87	2	2	61	0	3	220	50.0	3.20

(1) Apparent capacitance (C_a) in micromicrofarads.

(2) Where readings are not listed in columns "E" and "F" Antenna Tuning Unit BC-306-A is not used. The antenna circuit tuning given is considered the most efficient method of loading for the particular frequency used.

(3) Nominal 5-ohm phantom resistor.

f. Resistance Charts. To expedite the location of faults, the following point-to-point checks are suggested. Circuits which may be tested with a simple continuity meter (i.e., a voltmeter in series with a flashlight cell) are listed as having zero resistance. Average resistance values are tabulated and are to be tested with the Weston Voltohmmeter, Model 564, Type 3B of Test Set I-56-A. Individual radio transmitters will vary somewhat from the average values given, the maximum tolerance being approximately ten per cent.

Radio Transmitter BC-375-E

Refer to Schematic Diagram, Figure 49. All voltages, tuning unit, and back shield removed.

Master-oscillator and Power-amplifier Circuits

	OHMS
Point 61 of Socket SO-39 (1127) to socket shell, ground.....	1 meg.
Point 61 of Socket SO-39 (1127) to point 2 of tuning unit plugboard.....	10
Point 61 of Socket SO-39 (1127) to point 2 of transformer 1164.....	4
Point 2 of transformer 1164 to point 8 of tuning unit plug-board.....	115
Point 3 of tuning unit plugboard to grid terminal of MO socket.....	0
Point 4 of tuning unit plugboard to terminal 55 of Socket SO-41 (1126)...	7500
Point 6 of tuning unit plugboard to terminal 55 of Socket SO-41 (1126).	10,000

Modulator Circuits

Point 61 of Socket SO-39 (1127) to plate of socket 1161.....	70
Point 61 of Socket SO-39 (1127) to plate of socket 1162.....	70
Terminal 4 of transformer 1199 to grid of socket 1161.....	410
Terminal 4 of transformer 1199 to grid of socket 1162.....	410
Terminal 4 of transformer 1199 to terminal 55 of Socket SO-41 (1126)...	3000 to 7000

Speech-amplifier and Side-tone Circuits

Side-tone switch on tap 4, orange and green wire on 1179 to ground.....	150
Point 61 of Socket SO-39 (1127) to terminal 2 of transformer 1199.....	33,000
Terminal 2 of transformer 1199 to plate of socket 1154.....	650
Grid of socket 1154 to terminal 3 of transformer 1149.....	6000
Terminal 3 of transformer 1149 to terminal 55 of Socket SO-41 (1126).....	3100
Terminal 2 of transformer 1149 to ground.....	35
Terminal 1 of transformer 1149 to terminal 23 of Socket SO-44 (1128)....	
VOICE Position.....	0 to 200
CW or TONE Position.....	220

Dynamotor Unit PE-73-C

	OHMS
- L.V. input terminal to negative brush....	0
- L.V. input terminal to ground.....	0
+ L.V. brush to ground (brush removed)...	25
+ L.V. terminal to terminal 57 of Socket SO-41 (1601).....	50
+ L.V. brush to terminal 54 of Socket SO-41 (1601) fuses in.....	2
+ H.V. brush to - H.V. brush.....	87.5

The transmitter tuning unit circuits are shown in Figure 52. All circuits, not broken by a capacitor, are of low enough resistance to be checked by a continuity meter. The parasitic resistors are approximately 15 ohms and the radio-frequency chokes will have resistances between 1 and 40 ohms depending upon the tuning unit tested.

Various other circuits may be easily checked by reference to the values of resistances and tolerances given in section V, Supplementary Data.

g. Neutralization of Power Amplifier

Neutralization of the power amplifier is ordinarily unnecessary, since this is done when the units are tested at the manufacturer's plant. However, if the setting is disturbed for any reason, the following procedure may be used to restore the adjustment.

The radio transmitter should first be set up and tuned to see that all power supplies are correct and the radio transmitter is functioning properly. Then remove the power supply cords and the back shield of the radio transmitter. From Connection Diagram Figure 50, locate wire 43 (red) on filter capacitor 1197a. Remove this wire with a soldering iron, tape clear of terminal on capacitor 1197a and replace the back shield. This removes the power-amplifier d-c plate voltage and leaves the r-f circuits intact. Connect the vertical plates of a cathode-ray oscillograph to terminals LOAD A and GND. on the radio transmitter. Place the ANT. IND. TUNING, M, at dial zero and the ANT. CIRCUIT SWITCH, N, on position "3." Tune the P-A to resonance as shown by a maximum amplitude of r-f carrier on the oscillograph. Proceed by turning the neutralizing control, located behind the tuning chart, for a minimum amplitude on the oscillograph, at the same time maintaining the P-A in tune. When the best minimum is reached with the P-A in tune the tuning unit is neutralized. In the lower frequency tuning units, the oscillograph pickup will be practically zero at neutralization, while on the higher frequencies, considerable amplitude will be noticed from stray ground currents. A check on the neutralization may be made by noticing the low

reaction on the total plate current meter, at neutralization, as the P-A is tuned through resonance. The operator must remove all power plugs while the radio transmitter back cover is removed and lead (43) is resoldered.

h. Dynamotor Unit PE-73-C

(1) **BRUSHES:** The brushes can be removed by unscrewing the slotted brush cap on each side of the bearing bracket. It is recommended that each brush be suitably marked to indicate which brush holder it came from, and its relative position in that brush holder in order that the brushes may later be replaced in their original positions. **THIS IS IMPORTANT.** Blow out dust and clean all foreign matter from each brush holder and brush and make certain that the brushes slide freely in their brush holders, dressing the brushes with fine sandpaper, or a file, if necessary. Any brushes which have worn down to a length of less than $\frac{3}{8}$ in. (measured from contact surface to near end of spring) should be replaced with new ones. In installing new brushes it may be necessary to "sand-in" the brush in order to make its contact surface fit the contour of the commutator. The brush must slide freely in its holder. "Sanding-in" may be accomplished by using a strip of No. 00 sandpaper about 5 in. by 1 in. for L-V brushes and 8 in. by $\frac{5}{8}$ in. for H-V brushes. Wrap the strip of sandpaper around the commutator with the sand surface out. Insert the brushes in the brush holders and replace the brush caps so that the brushes are pressed tightly against the sandpaper. Holding the ends of the sandpaper so as to stretch it tightly against the commutator, rotate the armature back and forth until the full width of the brush face is making contact against the sandpaper as indicated by the sanding marks or scratches on the contact surface of the brush when it is withdrawn. Sand the sides of the brush if necessary, for a free fit in the holder. No sanding should be necessary to secure a good brush fit with the original brushes if they are replaced correctly. Never apply oil, grease or any other lubricant to the brush, commutator or brush holder. Under normal conditions of operation, it is estimated that the useful life of brushes is 2000 hours for low-voltage and 10,000 hours for high-voltage brushes.

(2) **COMMUTATORS:** Both commutators should be wiped with a clean, lintless cloth. Any scum appearing on the low-voltage commutator should be removed by moistening the cloth in naphtha or petroleum spirits. The normal black or dark brown polished surface on the high-voltage commutator should not be removed. The type of brush material used in the low-voltage brushes of

the dynamotor may, under certain conditions of installation, cause a discoloration of the low-voltage commutator. Under these circumstances the commutator will have a mottled appearance which is caused by the formation of a very thin oxide film on the surface of the commutator bars. This film is normal and is not injurious to the commutator or brushes. Do not try to remove the oxide film described above. A rough or pitted commutator should be smoothed with No. 00 or finer sandpaper. **NEVER USE EMERY CLOTH OR A FILE.** Under normal conditions of operation the low-voltage and high-voltage commutators should not require turning down before 2000 hours and 10,000 hours of service, respectively. However, if the commutator bars have worn down flush with the mica, the armature should be removed from the dynamotor to turn down the commutator face and undercut the mica between bars.

(3) **BEARINGS:** If the armature does not spin freely when rotated by hand with the brushes removed, the following may be the cause:

Dirt or other foreign matter in a bearing.

Defective ball bearing (cracked race, chipped or flattened ball).

Grease in bearing has become hard and gummy due to oxidation during long periods without actual use.

In any case, the armature should be removed from the frame as described under **DISASSEMBLY** and the bearings thoroughly cleaned. If, after cleaning, the outer race will not spin smoothly, it is probably due to a cracked race or chipped or flattened ball, and the defective bearing should be removed and replaced with a new one. Always use a bearing puller to remove a defective bearing and never hammer or pry the bearing off since this may bend the shaft and injure the commutator. A new bearing should be pressed on the shaft until the inner race of the bearing rests against the shoulder on the shaft. For this operation always use an arbor press and a metal cylinder or collar which bears only against the inner race of the bearing. Care must be taken that no force or stress is placed on the outer race of either bearing at any time since this will usually result in a damaged bearing.

(4) **DISASSEMBLY:** The following procedure is recommended for disassembling the dynamotor, for cleaning and repacking the bearings:

(a) Remove the three "safety-wired" screws on each end of the dynamotor and take off the two end bells.

(b) Unscrew the slotted brush cap in each brush holder and remove all four brushes. Take special care to mark the position of the brushes

in their holders such that they may later be replaced in their exact original positions.

(c) Unscrew the four slotted screws located around the rim of the low-voltage bearing bracket and pry the bracket loose from the frame. The low-voltage end of the dynamotor can be identified by the long, small diameter commutator and the large copper-graphite brushes.

(d) Detach the two field leads from the terminal clamps on the low-voltage brush holders by unscrewing the screw in each terminal clamp. It is not necessary or advisable to remove the terminal clamp from the brush holders.

(e) The bearing bracket can now be taken out of the way and the armature withdrawn from the frame. Take care not to injure the armature windings or commutator by rubbing against the field poles. Do not lose any shim washers which may be in the bearing housings, or which may stick to the bearing. If any shims are present they must be reassembled in the same housing.

(f) End Play Adjustment. A spanner screw is provided on one bearing bracket for adjusting end play in the dynamotor. This is properly adjusted at the factory and ordinarily will not need to be changed unless the armature is replaced. Before making any adjustments with this screw, it is necessary that the two setscrews on either side of the bearing be loosened. Then the spanner screw should be turned out (counterclockwise) one turn. Operate the dynamotor until it is hot (about 30 minutes). The end play should then be adjusted by turning the spanner screw as required until the end play as shown on an indicator reading to $1/1000$ inch, is between approximately $4/1000$ to $8/1000$ inch.

In case an indicator is not available an alternative method of adjusting the end play is as follows:

Screw the spanner screw in until the bearing starts to growl, then back it off immediately $\frac{1}{8}$ turn (45 degrees). This latter method must be used with extreme care since if the bearings

are set up too tight or allowed to remain tight for any period of time they may be damaged. The setscrews should then be tightened to hold the spanner nut in position.

(g) In cleaning the ball bearings it is not necessary to remove them from the armature shaft. Simply immerse the bearing in a shallow pan of clean naphtha or petroleum spirits and wash all of the grease from the bearing. The use of a small camel's-hair brush will greatly aid the thorough cleaning of the bearing. Change the cleaning solvent in the pan as soon as it becomes dirty. Always use clean solvent for the final rinsing of the bearings. **DO NOT ALLOW THE CLEANING SOLVENT TO COME IN CONTACT WITH THE COMMUTATORS OR WINDINGS.** In case the cleaning fluid is accidentally splashed on these parts, wipe it off immediately. Make certain the bearing is thoroughly clean and dry before repacking with new grease. If the bearing is not to be repacked with grease within a few minutes after cleaning, flush it with a clean, light mineral oil to protect the polished balls and races from rusting.

(5) REASSEMBLY: In reassembling the dynamotor, follow in reverse order the procedure for disassembly. Make certain that the two field leads are securely attached to the proper terminal clamps on the low-voltage brush holders and that the "slack" or "loop" in these leads is "tucked" back of the field coils. Do not loosen or remove the brush holders from the bearing brackets. If a brush holder is loosened or removed for any reason, replace it securely in exactly its original position and check to make certain the contact surface of the brush fits the commutator perfectly. If necessary, sand-in the brush to secure a good fit against the commutator. When reassembling a dynamotor furnished with an oil filler plug, start the screw threads by hand before using a screwdriver. Take care not to cross thread this screw. If the screw is cross threaded, metal particles may be dropped into the bearing causing roughness and probable bearing failure. The above precaution will obviously not be necessary on a dynamotor furnished without an oil hole.

SECTION V—SUPPLEMENTARY DATA

22. TABLE OF REPLACEABLE PARTS

Note: A number in parentheses after a reference number indicates that the reference covers more than one item and the quantity.

Reference No.	Stock No.	Renewal Part Designation	Name of Part	Description	Function	Drawing No. (G.E. Co.)	Mfr. Code No.
---------------	-----------	--------------------------	--------------	-------------	----------	------------------------	---------------

RADIO TRANSMITTER BC-375-E

1101	2C6191/S2	TSK-1	Socket	E. F. Johnson Co. for Tube VT-4-C	M-O tube interlock	Cat. 7461594-G1	2 17
1102	3Z9622-1	CSW-1	Switch	G-E Cat. GA19A14, modified	Interlock	ML-7876926-G1	2
1103			Capacitor		Tube thermal compensator	ML-7462641-G2	2
1104			Capacitor	(Part of 1103)	Calibration reset	ML-7462641-G2	2
1105	3DA6-4	C-9	Capacitor	0.006 mfd. \pm 10%, 2500 volts, Cornell-Dubilier Type 15L, modified	M-O plate by-pass	P-7761442-P12	3 4 5
1106	2C6191A/D1	RFC-14	Coil	Choke R-F	M-O plate R-F choke	ML-7461859-G1	2
1107(2)	3DA20-6	C-10	Capacitor	0.02 mfd \pm 10%, 1000 volts, Cornell-Dubilier Type 9L modified	P-A filament by-pass	P-7761443-P22	3 4 5
1108	3D9100-12	C-11	Capacitor	0.0001 mfd \pm 10%, 1000 volts	M-O grid by-pass	P-7761443-P23	3 4 5
1109(3)		R-2	Resistor	2500 ohms \pm 5%, 15 watt IRC Type DJ-1 (A) coating, modified	M-O grid	P-7761526-P7	1
1110	2C6191/S2	TSK-1	Socket	For tube VT-4-C	P-A tube	Cat. 7461594-G1	17
1111	3D9100-12	C-11	Capacitor	0.0001 mfd. \pm 10%, 1000 volts, Cornell-Dubilier Type 9L modified	P-A grid by-pass	P-7761443-P23	3
1112	3Z6400-1	R-3	Resistor	4000 ohms \pm 5%, 15 watts IRC Type, DJ-1 (A) coating, modified	P-A grid (fixed)	P-7761481-P10	1
1113	2C6191A/R31	VR-1	Resistor	3000 ohms, \pm 5%, -0%, no taper P. R. Mallory No. B-110348	Modulator bias (variable)	K-7870710	7

TABLE OF REPLACEABLE PARTS (Continued)

Reference No.	Stock No.	Renewal Part Designation	Name of Part	Description	Function	Drawing No. (G.E. Co.)	Mfr. Code No.
RADIO TRANSMITTER BC-375-E (Continued)							
1114	2C6191A/R31	VR-1	Resistor	3000 ohms +5%, -0%, no taper P. R. Mallory No. B-110348	S-A Bias (variable)	K-7870710	7
1115	3Z6720	R-4	Resistor	200,000 ohms \pm 10% 1 watt, red body, black end, yellow dot, IRC Type BT-1 waxed, modified	Keying	P-7761481-P27	1
1116(4)	3Z6725	R-5	Resistor	250,000 ohms \pm 10%, 1 watt, red body, green end, yellow dot, IRC Type BT-1 waxed, modified	H-V bridge	P-7761481-P3	1
1117	3DA1-9	C-12	Capacitor	0.001 mfd. \pm 5%, 4500 volts, Cornell- Dubilier Type 15L, mica	P-A plate by-pass	P-7761442-P13	3 4 5
1118	2C6191A/D1	RFC-14	Coil	Choke R-F	P-A plate Choke	ML-7461859-G1	2
1119	2C6191A/D2	RFC-15	Coil		H-V supply R.F. choke	ML-7462675-G1	2
1121	3F222	M-1	Ammeter IS-22	0-500 milliamperes DC white blocking on scale from 210 to 220 MA, G-E Type DW-41	Plate current	ML-7875379-G2	2
1122			Lamp LM-27	Mazda No. 44, 6.3 volts, 0.25 amp	Pilot		2
1126			Socket SO-41	For Plug PL-61	Dynamotor	ML-7761424-G1	17 2
1127			Socket SO-39	For Plug PL-59	Dynamotor	ML-7761427-G1	17 2
1128			Socket SO-44	For Plug PL-64	Junction box	ML-7761424-G2	17 2
1129	2Z5533A	J-1	Jack JK-33-A	P. R. Mallory Cat. No. B-114753	Microphone and key	ML-7461866-G1	2 7
1131	3Z9622-1	CSW-1	Switch	G-E Cat. GA19A14, modified	Test key	ML-7876926-G1	2
1133	3F7322	M-2	Voltmeter IS-122	G-E Type AW-41, 15 volts, AC-DC white blocking on scale at 10 volts	Filament	ML-7875379-G3	2

TABLE OF REPLACEABLE PARTS (Continued)

Reference No.	Stock No.	Renewal Part Designation	Name of Part	Description	Function	Drawing No. (G.E. Co.)	Mfr. Code No.
RADIO TRANSMITTER BC-375-E (Continued)							
1134	3DA10-17	C-14	Capacitor	0.01 mfd. $\pm 10\%$, 1000 volts, Cornell-Dubilier Type 9L, modified, mica	Filament voltmeter by-pass	P-7761443-P24	3 4 5
1135	3Z9692-21189	CSW-3	Switch	Single circuit, two way, 1 amp at 250 volts 3 amp at 125 volts, Arrow-Hart and Hegeman Elec. Co. Cat. No. 21189 modified	Filament voltmeter	ML-7876928-G1	6
1141	3Z9625	CSW-5	Switch	P. R. Mallory Cat. No. C-134593	Selector "TONE—CW-VOICE"	ML-7463230-G1	2 7
1142	3DA1-10	C-15	Capacitor	0.001 mfd. $\pm 10\%$, 2500 volts, Cornell-Dubilier Type 9L, modified, mica	Tone feedback	P-7761443-P20	3 4 5
1144	3DB1-1A	C-16	Capacitor	1 mfd $\pm 10\%$, 300 volts D.C. Cornell-Dubilier Type HC-1010A, modified	S-A grid by-pass	K-7870639-P1	2 4
1145	3Z6005-2	R-8	Resistor	50 ohms $\pm 10\%$, 4 watts, IRC Type AB-1(A) coating, modified	Microphone	P-7761481-P11	1
1146	3C324-4	AFC-1	Reactor	AF Choke, 0.5 henry, 0.1 amperes	Microphone filter	P-7762353-G1	2
1147	2C6191A/C9	C-17	Capacitor	25 mfd $+40\%$, -10% , 25 volts D.C. Cornell-Dubilier Type "A" Model MA-12658-PE, modified	Microphone filter	K-7870437-P1	3 4
1148	2C6191A/R32	VR-2	Resistor	200 ohms $\pm 10\%$, no taper P. R. Mallory Cat. No. B-110335	Input level	K-7870693-P1	7
1149	2Z9944	TR-1	Transformer		Microphone	P-7762352-G1	2
1150	3DA1-7	C-18	Capacitor	0.001 mfd $\pm 5\%$, 2500 volts, Cornell-Dubilier Type 9L modified	Microphone S-A grid	P-7761443-P8	2 4 5
1151	3Z6020-4	R-9	Resistor	200 ohms $\pm 5\%$, 2 watts IRC Type AA-1 (A) coating, modified	Input load	P-7761526-P10	1

TABLE OF REPLACEABLE PARTS (Continued)

Reference No.	Stock No.	Renewal Part Designation	Name of Part	Description	Function	Drawing No. (G.E. Co.)	Mfr. Code No.
RADIO TRANSMITTER BC-375-E (Continued)							
1154	2Z8759	TSK-2	Socket	Hammarlund Mfg. Co. S-4 modified	S-A tube VT-25	K-7870442-P1	17 9
1156(3)	3Z6611-1	R-11	Resistor	11,000 ohms $\pm 5\%$, 12 watts, IRC type DJ-1 (A) coating, modified	S-A plate	P-7761526-P8	1
1160	3DB1.1A	C-16	Capacitor	1 mfd $\pm 10\%$, 300 volts D.C. Cornell-Dubilier Type HC 1010A, modified	Modulator grid by-pass	K-7870639-P1	3 4
1161	2C6191/S2	TSK-1	Socket	For Tube VT-4-C	Modulator tube	Cat. ML-7461594-G1	17 2
1162	2C6191/S2	TSK-1	Socket	For Tube VT-4-C	Modulator tube	Cat. 7461594-G1	17 2
1164	2C6191A/T1	TR-3	Transformer		Modulation	P-7761432-G1	2
1166	3F289	M-3	Ammeter IS-89	8 amp. R.F., with thermocouple, G.E. Type DW-44	Antenna current	ML-7875379-G1	2
1167			Coil		Antenna inductance	ML-7761938-G1	2
1168	3Z9626	CSW-7	Switch	P.R. Mallory Cat. No. C134565	Antenna circuit	ML-7761425-G1 ML-7463231-G1	2 7
1169			Capacitor	22 mmf. to 118 mmf.	Antenna tuning (variable)		M-7463006-P1
1170			Coil		Antenna loading inductance	ML-7761429-G1	2
1172		FU-12-A	Fuse FU-12-A	0.5 amp, 1000 volts	Plate	Cat. 7871111-P1	2
1179	3Z9610A	CSW-6	Switch	Single section, one circuit, four point, non-shorting P.R. Mallory Type B-12473, modified Cat. No. B110062	Sidetone	K-7870711-P1	7
1180	3DA10-13	C-19	Capacitor	0.01 mfd $\pm 5\%$, 2500 volts, Cornell-Dubilier Type 9L modified	Modulator grid (tone)	P-7761443-P26	3 4 5
1181(2)	3Z6630-4	R-12	Resistor	30,000 ohms $\pm 5\%$, 1 watt, orange body, black end, orange dot, IRC Type BT-1 waxed, modified	Modulator grid	P-7761526-P12	1

TABLE OF REPLACEABLE PARTS (Continued)

Reference No.	Stock No.	Renewal Part Designation	Name of Part	Description	Function	Drawing No. (G.E. Co.)	Mfr. Code No.
RADIO TRANSMITTER BC-375-E (Continued)							
1183	3Z601045	R-13	Resistor		M-O grid parasitic	ML-7871909-G1	2
1184	3Z601045		Coil	(Ganged with 1183)	M-O grid parasitic	ML-7871909-G1	2
1185	3DB1.1A	C-16	Capacitor	1 mfd. $\pm 10\%$, 300 volts D.C., Cornell-Dubilier Type HC-1010A modified	Key filter	K-7870639-P1	3 4
1186	3Z5995	R-14	Resistor	5 ohms $\pm 5\%$, 2 watts, IRC Type AA-1 (A) coating	Key filter	P-7761526-P16	1
1187	3Z6010-30	R-16	Resistor	100 ohms $\pm 5\%$, 12 watts, IRC Type DJ-1 (A) coating	Pilot lamp	P-7762203-P20	1
1189		REL-4	Relay	C.P. Clare Co. Cat. No. 942-2	Antenna switching	ML-7660600-G2	2 18
1190	3Z9692-21189	CSW-2	Switch	Arrow-Hart & Hegeman Elec. Co. Cat. 80600, double pole, single throw, 6 amp at 250 volts, 12 amp at 125 volts	Filament	ML-7876927-G1	2 6
1191		R-17	Resistor	5 ohms $\pm 5\%$, 12 watts, IRC Type DJ-1 (A) coating, modified	S-A filament	P-7762203-P21	1
1192	3Z5995-5	R-17	Resistor	5 ohms $\pm 5\%$, 12 watts, IRC Type DJ-1 (A) coating, modified	S-A filament	P-7762203-P21	1
1193	3Z6015-9	R-18	Resistor	150 ohms, $\pm 5\%$, 8 watts IRC Type DG-1 (A) coating modified	Microphone	P-7762203-P22	1
1194		CSW-2	Switch	Arrow-Hart & Hegeman Elec. Co. Cat. 80600 double-pole, single-throw, 6 amp at 250 volts, 12 amp at 125 volts	Off-On	ML-7876927-G1	2 6
1196	3Z5992-3	R-15	Resistor	2.70 ohms 36 watts, 3.70 ohms, 26 watts dissipation; blue stick resistor mounted on tapped connection board	Filament	ML-7762959-G2	2

TABLE OF REPLACEABLE PARTS (Continued)

Reference No.	Stock No.	Renewal Part Designation	Name of Part	Description	Function	Drawing No. (G.E. Co.)	Mfr. Code No.
---------------	-----------	--------------------------	--------------	-------------	----------	------------------------	---------------

RADIO TRANSMITTER BC-375-E (Continued)

1197A	3DB1.45	C-34	Capacitor	1-1-1 mfd, 3000 volts D.C., G-E Type 25F34 modified	Modulator plate by-pass	K-7877630	2 3 4
1197B	3DB1.45	C-34	Capacitor	(Included in 1197A)	S-A plate by-pass	K-7877630	2 3 4
1197C	3DB1-49	C-34	Capacitor	(Included in 1197A)	Filter	K-7877630	2 3 4
1198	3Z9627	CSW-8	Switch	P.R. Mallory Cat. No. C-134576	Antenna tap	ML-7762960-G2	2 7
1199		TR-4	Transformer		Interstage	M-7466445-P1	2

TRANSMITTER TUNING UNIT TU-5-B
(1500-3000 KC)

501			Inductance		M-O tank	ML-7761605-G1	2
502	3Z9614	CSW-9	Switch	(Ganged with 522) P.R. Mallory Cat. No. C-134574	M-O band change	ML-7659203-G2	2 7
503	3D9100-11	C-1	Capacitor	0.0001 mfd. $\pm 2\%$, 3000 volts, Cornell-Dubilier Type 15H, modified	M-O tank	P-7761662-P3	3 4 5
504	3D9100-11	C-1	Capacitor	0.0001 mfd. $\pm 2\%$, 3000 volts, Cornell-Dubilier Type 15H, modified	M-O tank	P-7761662-P3	3 4 5
505	3D9100-11	C-1	Capacitor	0.0001 mfd. $\pm 2\%$, 3000 volts, Cornell-Dubilier Type 15H, modified	M-O tank	P-7761662-P3	3 4 5
506	3D9030-1	C-2	Capacitor	0.00003 mfd. $\pm 5\%$, 2000 volts, Cornell-Dubilier Type 15H, modified	M-O tank	P-7761662-P1	3 4 5
507		VC-2	Capacitor	135 mmf. max., $\pm 2\%$; 20 mmf. min., ± 1 mmf.	M-O tank (variable)	P-7761569-P2	9 10

TABLE OF REPLACEABLE PARTS (Continued)

Reference No.	Stock No.	Renewal Part Designation	Name of Part	Description	Function	Drawing No. (G.E. Co.)	Mfr. Code No.
TRANSMITTER TUNING UNIT TU-5-B (Continued) (1500-3000 KC)							
508		RFC-1	Coil	(With resistor 517)	P-A grid choke	ML-7462657-G1	2
509	3D9400-6	C-3	Capacitor	0.0004 mfd. $\pm 10\%$, 5000 volts, Cornell-Dubilier Type 9HL, modified	P-A grid blocking	P-7761663-P1	3 4
510	3D9400-6	C-3	Capacitor	0.0004 mfd. $\pm 10\%$, 5000 volts, Cornell-Dubilier Type 9HL modified	M-O grid blocking	P-7761663-P1	3 4 5
511	2C8005A/D11	RFC-2	Coil		M-O grid choke	ML-7462706-G1	2
512		VC-14	Capacitor	26 mmf. max., $\pm 4\%$; 8 mmf. min. ± 1.5 mmf.	Neutralizing	T-7660443-P8	9 10
513			Compensator			ML-7462769-G1	2
514			Compensator	(Ganged with 513)		ML-7462769-G1	2
515			Compensator	(Ganged with 513)		ML-7462769-G1	2
516			Compensator	(Ganged with 513)		ML-7462769-G1	2
517		RFC-1	Resistor	G-E Type QLK, 15 ohms, 4.5 watts	P-A grid parasitic	QLK-2155993 15 ohms	2
521			Inductance	(Ganged with 528)	P-A tank	ML-7761615-G1	2
522	3Z9614	CSW-9	Switch	(Ganged with 502) P. R. Mallory Cat. No. C-134574	P-A band change	ML-7659203-G2	2 7
523	3D9090	C-4	Capacitor	0.00009 mfd. $\pm 5\%$, 3000 volts, Cornell-Dubilier Type 15L, modified	P-A tank	T-7761442 P15	3 4 5
524	3D9090	C-4	Capacitor	0.00009 mfd. $\pm 5\%$, 3000 volts, Cornell-Dubilier Type 15L, modified	P-A tank	T-7761442-P15	3 4 5
525	3D9090	C-4	Capacitor	0.00009 mfd. $\pm 5\%$, 3000 volts, Cornell-Dubilier Type 15L, modified	P-A tank	T-7761442-P15	3 4 5
527		VC-12	Capacitor	156 mmf. max., $\pm 3\%$, 20 mmf. min. ± 1.5 mmf.	P-A tank (variable)	T-7660443-P6	9 10
528			Coil	(Ganged with 521)	Antenna coupling	ML-7761615-G1	2
529	3Z9604-2	CSW-10	Switch	Antenna switch	Antenna coupling	{ ML-7762960-G1 ML-7659203-G3 }	} 2

TABLE OF REPLACEABLE PARTS (Continued)

Reference No.	Stock No.	Renewal Part Designation	Name of Part	Description	Function	Drawing No. (G.E. Co.)	Mfr. Code No.
TRANSMITTER TUNING UNIT TU-6-B (3000-4500 KC)							
601	3Z9612A	CSW-11	Inductance	(Ganged with 622) P. R. Mallory Cat. No. C-134573	M-O tank	ML-7761606-G1	2
602			Switch		M-O band change	ML-7659555-G1	2 7
603	3D9050-3	C-7	Capacitor	0.00005 mfd. $\pm 5\%$, 3000 volts, Cornell-Dubilier Type 15H, modified	M-O tank	P-7761662-P2	3 4 5
607	2C8006A/D14	VC-3	Capacitor	77 mmf., max., $\pm 2\%$; 15 mmf. min., ± 1 mmf.	M-O tank (variable)	P-7761569-P3	9 10
608	3D9400-6	RFC-3	Coil	(With resistor 614)	P-A grid choke	ML-7462659-G2	2
609		C-3	Capacitor	0.0004 mfd. $\pm 10\%$, 5000 volts, Cornell-Dubilier Type 9HL, modified	P-A grid blocking	P-7761663-P1	3 4 5
610	3D9400-6	C-3	Capacitor	0.0004 mfd., $\pm 10\%$, 5000 volts, Cornell-Dubilier Type 9HL, modified	M-O grid blocking	P-7761663-P1	3 4 5
611		RFC-4	Coil		M-O grid choke	ML-7462659-G1	2
612	3D9400-6	VC-14	Capacitor	26 mmf. max., $\pm 4\%$; 8 mmf. min., ± 1.5 mmf.	Neutralizing	T-7660443-P8	9 10
613		3D9400-6	RFC-3	Compensator	G-E Type QLK, 15 ohms, 4.5 watts	M-O tuning	ML-7462707-G1
614	Resistor			P-A grid parasitic		QLK-2155993	2
621	3Z9612-A	CSW-11	Inductance	(Ganged with 602) P. R. Mallory Cat. No. C-134573	P-A tank	ML-7761616-G1	2
622			Switch		P-A band change	ML-7659555-G1	2 7
623	3D9050-1	C-6	Capacitor	0.00005 mfd. $\pm 5\%$, 3000 volts, Cornell-Dubilier Type 15L, modified	P-A fixed tank	P-7761442-P11	3 4 5
627	3D9050-1	VC-8	Capacitor	116 mmf. max., $\pm 3\%$; 19 mmf. min., ± 1.5 mmf.	P-A tank (variable)	T-7660443-P1	9 10
628		Coil	(Ganged with 621)	Antenna coupling	ML-7761616-G1	2	
629	3Z9604-2	CSW-10	Switch	P. R. Mallory Cat. No. C-134570	Antenna coupling	ML-7762960-G1	2 7

TABLE OF REPLACEABLE PARTS (Continued)

Reference No.	Stock No.	Renewal Part Designation	Name of Part	Description	Function	Drawing No. (G.E. Co.)	Mfr. Code No.
TRANSMITTER TUNING UNIT TU-7-B (4500-6200 KC)							
701			Inductance		M-O tank	ML-7761607-G1	2
702		VC-4	Capacitor	111 mmf. max. ± 2%, 23 mmf. min. = 1 mmf.	M-O tank variable	P-7761569-P4	9 10
703	3D9400-6	C-3	Capacitor	0.0004 mfd. ± 10%, 5000 volts, Cornell- Dubilier Type 9HL, modified	M-O grid blocking	P-7761663-P1	3 4 5
704	3D9400-6	RFC-5	Coil		M-O grid choke	ML-7462659-G3	2
705	2C8007A/D3	C-3	Capacitor	0.0004 mfd. ± 10%, 5000 volts, Cornell- Dubilier Type 9HL, modified	P-A grid blocking	P-7761663-P1	3 4 5
706		RFC-6	Coil		P-A grid choke	ML-7462639-G1	2
707		VC-14	Capacitor	26 mmf. max., ± 4%, 8 mmf. min., = 1.5 mmf.	Neutralizing	T-7660443-P8	9 10
721			Inductance		P-A tank	ML-7761617-G1	2
722		VC-9	Capacitor	116 mmf. max., ± 2.5%, 19 mmf. min., = 1.5 mmf.	P-A tank (variable)	T-7660443-P2	9 10
723			Coil	(Ganged with 721)	Antenna coupling	P-7761617-G1	2
724	3Z9604-2	CSW-10	Switch	P. R. Mallory Cat. No. C-134750	Antenna coupling	ML-7762960-G1	2 7
TRANSMITTER TUNING UNIT TU-8-B (6200-7700 KC)							
801			Inductance		M-O tank	ML-7761608-G1	2
802		VC-5	Capacitor	66 mmf. max., ± 2%; 14 mmf. min., = 1 mmf.	M-O tank (variable)	P-7761569-P5	9 10
803	3D9400-6	C-3	Capacitor	0.0004 mfd. ± 10%, 5000 volts, Cornell- Dubilier Type 9HL, modified	M-O grid blocking	P-7761663-P1	3 4 5
804	2C8008A/D5	RFC-7	Coil		M-O grid choke	ML-7462638-G1	2
805	3D9400-6	C-3	Capacitor	0.0004 mfd. ± 10%, 5000 volts, Cornell- Dubilier Type 9HL, modified	P-A grid blocking	P-7761663-P1	3 4 5
806	2C8008A/D12	RFC-8	Coil		P-A grid choke	ML-7462658-G1	2

TABLE OF REPLACEABLE PARTS (Continued)

Reference No.	Stock No.	Renewal Part Designation	Name of Part	Description	Function	Drawing No. (G.E. Co.)	Mfr. Code No.
---------------	-----------	--------------------------	--------------	-------------	----------	------------------------	---------------

TRANSMITTER TUNING UNIT TU-8-B (Continued)
(6200-7700 KC)

807		VC-14	Capacitor	26 mmf. max., ± 4%; 8 mmf. min., ± 1.5 mmf.	Neutralizing	T-7660443-P8	9 10
821		VC-13	Inductance	(Ganged with 823)	P-A tank	ML-7761618-G1	2
822	Capacitor		81 mmf. max., ± 3%; 15 mmf. min., ± 1.5 mmf.	P-A tank (variable)	T-7660443-P7	9 10	
823			Coil	(Ganged with 821)	Antenna coupling	ML-7761618-G1	2
824	3Z9604-2	CSW-10	Switch	P. R. Mallory Cat. No. C-134570	Antenna coupling	ML-7762960-G1	2 7

TRANSMITTING TUNING UNIT TU-9-B
(7700-10,000 KC)

901		VC-6	Inductance	77 mmf. max ± 2%, 15 mmf. min. ± 1 mmf.	M-O tank	ML-7761609-G1	2
902	Capacitor		M-O tank (variable)		P-7761569-P6	9 10	
903	3D9400-6	C-3	Capacitor	0.0004 mfd. ± 10%, 5000 volts, Cornell- Dubilier Type 9HL, modified	M-O grid blocking	P-7761663-P1	3 4 5
904	2C8009A/D6	RFC-9	Coil	0.0004 mfd. ± 10%, 5000 volts, Cornell- Dubilier Type 9HL, modified	M-O grid choke	ML-7462662-G1	2
905	3D9400-6	C-3	Capacitor		P-A grid blocking	P-7761663-P1	3 4 5
906	2C8009A-D7	RFC-10	Coil	26 mmf. max. ± 4%, 8 mmf. min., ± 1.5 mmf.	P-A grid choke	ML-7463044-G1	2
907		VC-14	Capacitor		Neutralizing	T-7660443-P8	9 10
909	3D9400-3	C-8	Capacitor	0.0004 mfd. ± 5%, 5000 volts, Cornell- Dubilier Type 9L, modified	M-O by-pass	P-7761443-P2	3 4 5
921		VC-10	Inductance	(Ganged with 923)	P-A tank	ML-7761619-G1	2
922	Capacitor		116 mmf. max., ± 2.5%; 19 mmf. min. ± 1.5 mmf.	P-A tank (variable)	T-7660443-P3	9 10	
923			Coil	(Ganged with 921)	Antenna coupling	ML-7761619-G1	2
924	3Z9604-2	CSW-10	Switch	P. R. Mallory Cat. No. C-134570	Antenna coupling	ML-7762960-G1	2 7

TABLE OF REPLACEABLE PARTS (Continued)

Reference No.	Stock No.	Renewal Part Designation	Name of Part	Description	Function	Drawing No. (G.E. Co.)	Mfr. Code No.
TRANSMITTER TUNING UNIT TU-10-B (10,000-12,500 KC)							
1001			Inductance		M-O tank	ML-7761610-G1	2
1002		VC-7	Capacitor	62 mmf. max., ± 2%, 14 mmf. min., ± 1 mmf.	M-O tank (variable)	P-7761569-P7	9 10
1003	3D9400-6	C-3	Capacitor	0.0004 mfd. ± 10%, 5000 volts, Cornell- Dubilier Type 9HL, modified	M-O grid blocking	P-7761663-P1	3 4 5
1004	2C8010A/D7	RFC-11	Coil		M-O grid choke	ML-7462661-G1	2
1005	3D9400-6	C-3	Capacitor	0.0004 mfd. ± 10%, 5000 volts, Cornell- Dubilier Type 9HL, modified	P-A grid blocking	P-7761663-P1	3 4 5
1006	2C8010A/D8	RFC-12	Coil		P-A grid choke	ML-7463045-G1	2
1007		VC-14	Capacitor	26 mmf. max., ± 4%, 8 mmf. min., ± 1.5 mmf.	Neutralizing	T-7660443-P8	9 10
1009		C-8	Capacitor	0.0004 mfd. ± 5%, 5000 volts, Cornell- Dubilier Type 9L, modified	M-O by-pass	P-7761443-P2	3 4 5
1010	2C8010A/D16	RFC-13	Coil		M-O choke	ML-7462679-G1	2
1021			Inductance	(Ganged with 1023)	P-A tank	ML-7761620-G1	2
1022		VC-11	Capacitor	116 mmf. max., ± 2.5%, 19 mmf. min., ± 1.5%	P-A tank (variable)	T-7660443-P4	9 10
1023			Coil	(Ganged with 1021)	Antenna coupling	ML-7761620-G1	2
1024	3Z9604-2	CSW-10	Switch	P. R. Mallory Cat. No. C-134-570	Antenna coupling	ML-7762960-G1	2 7
TRANSMITTER TUNING UNIT TU-26-B (200-500 KC)							
2601			Variometer		M-O tank	ML-7763683-G2	2
2602		RFC-16	Coil		M-O plate choke	ML-7463139-G1	2
2603		RFC-20	Coil	(With resistor 2617)	M-O grid choke	ML-7463144-G3	2
2604		C-21	Capacitor	0.002 mfd. ± 10%, 5000 volts, Cornell- Dubilier Type 9HL, modified	M-O plate	P-7761663-P2	3 4 5

TABLE OF REPLACEABLE PARTS (Continued)

Reference No.	Stock No.	Renewal Part Designation	Name of Part	Description	Function	Drawing No. (G.E. Co.)	Mfr. Code No.
---------------	-----------	--------------------------	--------------	-------------	----------	------------------------	---------------

TRANSMITTER TUNING UNIT TU-26-B (Continued)
(200-500 KC)

2605			Capacitor	17 mmf. \pm 1 mmf. finished capacity	Compensating	K-7883695	2
2606		RFC-18	Coil		P-A grid choke	ML-7463142-G1	2
2607		CSW-13	Switch	(Ganged with 2622) P. R. Mallory Cat. No. C-134575	M-O band change	ML-7659203-G3	2 7
2608		C-38	Capacitor	0.0004 mfd. \pm 5%, 3000 volts, Cornell-Dubilier Type PL, modified	M-O tank	K-7872594-P6	3 4 5
2609		C-38	Capacitor	0.0004 mfd. \pm 5%, 3000 volts, Cornell-Dubilier Type PL, modified	M-O tank	K-7872594-P6	3 4 5
2610		C-35	Capacitor	0.005 mfd. \pm 5%, 5000 volts, Cornell-Dubilier Type 9HL, modified	M-O chain	P-7761663-P4	3 4 5
2611		C-40	Capacitor	0.004 mfd. \pm 5%, 5000 volts, Cornell-Dubilier Type 9HL, modified	M-O chain	P-7761663-P18	3 4 5
2612		C-40	Capacitor	0.004 mfd. \pm 5%, 5000 volts, Cornell-Dubilier Type 9HL, modified	M-O chain	P-7761663-P18	3 4 5
2613		C-25	Capacitor	0.0035 mfd. \pm 5%, 5000 volts, Cornell-Dubilier Type 9HL, modified	M-O chain	P-7761663-P15	3 4 5
2614		C-25	Capacitor	0.0035 mfd. \pm 5%, 5000 volts, Cornell-Dubilier Type 9HL, modified	M-O chain	P-7761663-P15	3 4 5
2615		C-35	Capacitor	0.005 mfd. \pm 5%, 5000 volts, Cornell-Dubilier Type 9HL, modified	M-O chain	P-7761663-P4	3 4 5
2616		VC-14	Capacitor	26 mmf. max. \pm 4%; 8 mmf. min. \pm 1.5 mmf.	Neutralizing	T-7660443-P8	9 10
2617		RFC-20	Resistor	G-E Type QLK, 15 ohms, 4.5 watts	M-O grid parasitic	QLK-2155993 15 ohms	2

TABLE OF REPLACEABLE PARTS (Continued)

Reference No.	Stock No.	Renewal Part Designation	Name of Part	Description	Function	Drawing No. (G.E. Co.)	Mfr. Code No.
---------------	-----------	--------------------------	--------------	-------------	----------	------------------------	---------------

TRANSMITTER TUNING UNIT TU-26-B (Continued)
(200-500 KC)

2618		C-21	Capacitor	0.002 mfd. \pm 10%, 5000 volts, Cornell-Dubilier Type 9HL, modified	P-A grid	P-7761663-P2	3 4 5
2619			Capacitor	12 mmf. \pm 1 mmf. finished capacity	Compensating	K-7883696	2
2620			Capacitor	35 mmf. +0 mmf. -2 finished capacity	Compensating	K-7883727	2
2621			Variometer		P-A tank	ML-7763683-G1	2
2622		CSW-13	Switch	(Ganged with 2607) P. R. Mallory Cat. No. C-134575	P-A band change	ML-7659203-G3	2
2623		C-42	Capacitor	0.0004 mfd. \pm 5%, 3000 volts, Cornell-Dubilier Type PL, modified	P-A tank	P-7761442-P4	3 4 5
2624		C-41	Capacitor	0.0005 mfd. \pm 5%, 3000 volts, Cornell-Dubilier Type PL, modified	P-A tank	P-7761442-P5	3 4 5
2625		C-39	Capacitor	0.0007 mfd. \pm 5%, 3000 volts, Cornell-Dubilier Type PL, modified	P-A tank	P-7761442-P18	3 4 5
2627			Coil	(Ganged with 2621)	Antenna coupling	ML-7763683-G1	2
2628		CSW-10	Switch	P. R. Mallory Cat. No. C-134570	Antenna coupling	ML-7762960-G1	2 7

ANTENNA TUNING UNIT BC-306-A

1501	3Z9604	CSW-12	Switch	P. R. Mallory Cat. No. C-134569	Antenna variometer	ML-7463975-G1	2 7
1502			Variometer		Antenna tuning	ML-7761714-G1	2

DYNAMOTOR PE-73-C

1601			Socket SO-41	(For Plug PL-61)	Plug receptacle	ML-7761424G1 Signal Corps Dwg. SC-D-457	17 2
------	--	--	--------------	------------------	-----------------	---	---------

TABLE OF REPLACEABLE PARTS (Continued)

Reference No.	Stock No.	Renewal Part Designation	Name of Part	Description	Function	Drawing No. (G.E. Co.)	Mfr. Code No.
DYNAMOTOR PE-73-C (Continued)							
1602			Socket SO-39	(For Plug PL-59)	Plug receptacle	ML-7761427G1 Signal Corps Dwg. SC-D-457	17 2
1604	3Z1913	FU-13	Fuse FU-13	30 amp. 250 volts G-E Cat. GE1027	Transmitter L-V Supply	K-7870616P1	2
1605	3Z1922	FU-22	Fuse FU-22	60 amp, 250 volts Bussman Mfg. Co. Cat. 1021, modified	Dynamotor L-V	K-7870604P1	8
1607	3DA5-28	C-20	Capacitor	0.005 mfd. \pm 5%, 5000 volts, Cornell- Dubilier Type 9L, modified	H-V filter	P-7761443-P6	3 4 5
1608	3Z1918A	FU-18	Fuse FU-18-A	1 amp. 1000 volts, G-E Cat. 78X159 modified	Dynamotor H-V	K-7870617-P1	2
1609	3DA10-17	C-14	Capacitor	0.01 mfd. \pm 10%, 1000 volts, Cornell- Dubilier Type 9L, modified	L-V filter	P-7761443-P24	3 4 5
1610		REL-3	Relay	Nominal coil voltage 24 volts D.C. G-E Cat. CR2800-384A3	Starting	M-7464026-P3	2
1613	3DA15-6	C-31	Capacitor	0.015 mfd. \pm 10%, 5000 volts, Cornell- Dubilier Type 9L, modified	Filter	P-7762618-P6	3 4
1614	3DA15-6	C-31	Capacitor	0.015 mfd. \pm 10%, 5000 volts, Cornell- Dubilier Type 9L, modified	Filter	P-7762618-P6	3 4
1615	3DA10-84	C-32	Capacitor	0.01 mfd. \pm 10%, 600 volts Cornell- Dubilier Type 3YL, modified	Filter	P-7761774-P8	3 4 5
1616	3DA10-85	C-33	Capacitor	0.01 mfd. \pm 10%, 600 volts Cornell- Dubilier Type 3LL, modified	Filter	P-7761774-P7	3 4 5
1618			Dynamotor	28/1000 volts, 5000 rpm, G-E Model 5D48B9		K-7876653	2

MOUNTINGS

	3H3907	FT-107	Mounting FT-107		Part of Dynamotor Unit PE-73-C—	ML-7461031-G1 Signal Corps Dwg. SC-D-447	2
--	--------	--------	--------------------	--	---------------------------------------	--	---

TABLE OF REPLACEABLE PARTS (Continued)

Reference No.	Stock No.	Renewal Part Designation	Name of Part	Description	Function	Drawing No. (G.E. Co.)	Mfr. Code No.
MOUNTINGS (Continued)							
	2Z6665B	FT-115-B	Mounting FT-115-B		Disposable for use with Radio Transmitter BC-375-E	ML-7463135-G1 Signal Corps Dwg. SC-C-2286	2
	2Z6682	FT-142	Mounting FT-142		Part of Antenna tuning unit	ML-7462801-G1 Signal Corps Dwg. SC-D-2389	2
	3Z6691A	FT-151-A	Mounting FT-151-A		Part of Radio Transmitter BC-375-E	ML-7761671-G1 Signal Corps Dwg. SC-D-2290	2

23. TABLE OF INTERCHANGEABLE PARTS

**THE FOLLOWING ITEMS OF THE SAME TYPE ARE
ELECTRICALLY AND MECHANICALLY INTERCHANGEABLE**

Description	Reference Numbers
Capacitor, 5000 volts rated 0.0004 mfd. $\pm 10\%$	509, 510, 609, 610, 703, 705, 803, 805, 903, 905, 1003, 1005
Capacitor, 3000 volts, rated 0.0001 mfd. $\pm 2\%$	503, 504, 505
Capacitor, 5000 volts, rated 0.015 mfd. $\pm 10\%$	1613, 1614
Capacitor, 5000 volts, rated 0.002 mfd. $\pm 10\%$	2604, 2618
Capacitor, 5000 volts, rated 0.0035 mfd. $\pm 5\%$	2613, 2614
Capacitor, 3000 volts, rated 0.0004 mfd. $\pm 5\%$	2608, 2609
Capacitor, 5000 volts, rated 0.004 mfd. $\pm 5\%$	2611, 2612
Capacitor, 5000 volts, rated 0.005 mfd. $\pm 5\%$	2610, 2615
Capacitor, 3000 volts, rated 0.00009 mfd. $\pm 5\%$	523, 524, 525
Capacitor, 1000 volts, rated 0.0001 mfd. $\pm 10\%$	1108, 1111
Capacitor, 5000 volts, rated 0.0004 mfd. $\pm 5\%$	909, 1009
Capacitor, 300 volts, rated 1.0 mfd. $\pm 10\%$	1144, 1160, 1185
Capacitor, 1000 volts, rated 0.01 mfd. $\pm 10\%$	1134, 1609
Capacitor, 8 to 26 mmf.	512, 612, 707, 807, 907, 1007, 2616
Choke, r.f., G-E ML-7461859-G1	1106, 1118
Resistor, wire wound, rated 5 ohms, 12 watts	1191, 1192
Resistor, wire wound, rated 15 ohms, 45 watts	517, 614, 2617
Resistor, variable, rated 3000 ohms	1113, 1114
Socket SO-39 for Plug PL-59	1127, 1602
Socket SO-41 for Plug PL-61	1126, 1601
Socket for Tube VT-4-C	1101, 1110, 1161, 1162
Switch, filament, G-E ML-7876926-G1	1102, 1131
Switch, filament, G-E ML-7876927-G1	1190, 1194
Switch, antenna, G-E ML-7762960-G1	529, 629, 724, 824, 924, 1024, 2628
Switch, antenna, G-E ML-7659203-G3	2607, 2622

24. RENEWAL PARTS

Spare Part Designation	Electrical Rating	Mfr. Code No.	Dimensions in Inches				Wt. in Lbs.	Description
			Length	Width	Height	Dia.		
AFC-1	0.5 henry, 0.1 amp.	2	2.25	2.50	2.59		0.685	Microphone filter reactor
ARM-2		2	9.375				3.25	7.25
BG-1		2			0.5	1.25	0.065	Dynamotor bearing
BP-3		2			2.187	2.06	0.187	Binding post on antenna tuning unit
BP-4		2						Binding post on antenna tuning unit
BP-5		2	6.84	2.25	0.187		0.560	Antenna binding post on transmitter
BR-5	H-v for dynamotor	2	0.625	0.25	0.25		0.017	Dynamotor brush
BR-6	L-v for dynamotor	2	0.80	0.75	0.437		0.083	Dynamotor brush
C-1	0.0001 mfd. 3000 volts	3, 4, 5	2.81	0.937	1.937		0.270	Mica capacitor
C-2	0.00003 mfd. 2000 volts	3, 4, 5	2.81	0.937	1.937		0.225	Mica capacitor
C-3	0.0004 mfd. 5000 volts	3, 4, 5	1.75	1.32	1.781		0.129	Mica capacitor
C-4	0.00009 mfd. 3000 volts	3, 4, 5	2.81	0.937	1.937		0.270	Mica capacitor
C-6	0.00005 mfd. 3000 volts	3, 4, 5	2.81	0.937	1.937		0.229	Mica capacitor
C-7	0.00005 mfd. 3000 volts	3, 4, 5	2.81	0.937	1.937		0.229	Mica capacitor
C-8	0.0004 mfd. 5000 volts	3, 4, 5	1.75	1.32	0.468		0.068	Mica capacitor
C-9	0.006 mfd. 2500 volts	3, 4, 5	2.81	0.937	1.937		0.242	Mica capacitor
C-10	0.02 mfd. 1000 volts	3, 4, 5	1.75	1.32	0.468		0.090	Mica capacitor
C-11	0.0001 mfd. 1000 volts	3, 4, 5	1.75	1.32	0.468		0.066	Mica capacitor
C-12	0.001 mfd. 4500 volts	3, 4, 5	2.81	0.937	1.937		0.250	Mica capacitor
C-14	0.01 mfd. 1000 volts	3, 4, 5	1.75	1.32	0.468		0.074	Mica capacitor
C-15	0.001 mfd. 2500 volts	3, 4, 5	1.75	1.32	0.468		0.070	Mica capacitor
C-16	1 mfd. 300 volts	3, 4	2.75	2.07	1.00		0.217	Paper capacitor
C-17	25 mfd. 25 volts	3, 4, 5	2.12	1.43	2.75		0.140	Electrolytic capacitor
C-18	0.001 mfd. 2500 volts	3, 4, 5	1.75	1.32	0.468		0.070	Mica capacitor
C-19	0.01 mfd. 2500 volts	3, 4, 5	1.75	1.32	0.468		0.074	Mica capacitor
C-20	0.005 mfd. 5000 volts	3, 4, 5	1.75	1.32	0.468		0.072	Mica capacitor
C-21	0.002 mfd. 5000 volts	3, 4, 5	1.75	1.31	0.78		0.126	Mica capacitor
C-25	0.0035 mfd. 5000 volts	3, 4, 5	1.75	1.31	0.78		0.126	Mica capacitor
C-31	0.015 mfd. 5000 volts	3	1.75	1.312	0.781		0.125	Mica capacitor
C-32	0.01 mfd. 600 volts	3, 4, 5	2.625	0.625	0.312		0.0234	Mica capacitor
C-33	0.01 mfd. 600 volts	3, 4, 5	1.937	0.625	0.312		0.0312	Mica capacitor
C-34	1-1-1 mfd. 3000 volts	2	4.75	2.5	3.0			Pyranol askarel filled capacitor
C-35	0.005 mfd. 5000 volts	3, 4, 5	0.781	1.312	1.75		0.125	Mica capacitor
C-38	0.0004 mfd. 3000 volts	3, 4, 5						Mica capacitor
C-39	0.0007 mfd. 3000 volts	3, 4, 5						Mica capacitor
C-40	0.004 mfd. 5000 volts	3, 4, 5						Mica capacitor
C-41	0.0005 mfd. 3000 volts	3, 4, 5						Mica capacitor
C-42	0.0004 mfd. 3000 volts	3, 4, 5						Mica capacitor
CSW-1		2	1.18	0.531	1.56		0.036	Interlock switch and test key
CSW-2		6	1.75	0.75	1.59		0.062	On-off switch
CSW-3		6	1.56	0.625	1.32		0.032	Voltmeter switch

RENEWAL PARTS (Continued)

Spare Part Designation	Electrical Rating	Mfr. Code No.	Dimensions in Inches				Wt. in Lbs.	Description
			Length	Width	Height	Dia.		
CSW-5		2	2.63	2.63	2.109		0.150	Selector switch
CSW-6		7, 12	1.5	2.38	2.0		0.106	Side-tone switch
CSW-7		2	5.38	2.75	2.75		0.565	Antenna circuit
CSW-8		2, 7	2.625	2.625	2.625		0.343	Antenna tap switch
CSW-9		2, 7	10.0	2.56	2.43		0.55	Tandem control switch
CSW-10		2, 7	2.625	2.625	2.625		0.343	Antenna coupling switch
CSW-11		2, 7	10.0	2.56	2.38		0.498	Tandem control switch
CSW-12		2	5.18			2.75	0.594	Antenna variometer switch
CSW-13		2, 7	10.0	2.56	3.0		0.656	Tandem control switch
FT-107		2	10.62	7.5	0.82		1.45	Mounting FT-107
FT-115		2	2.12	2.31	1.21		0.195	Mounting FT-115-B
FT-151-A		2	2.20	8.0	1.35		3.797	Mounting FT-151-A
FU-12	0.5 amp 1000 volts	2	3.0			0.50	0.018	Fuse FU-12-A
FU-13	30 amp. 250 volts	2	2.0			0.56	0.055	Fuse FU-13
FU-18	1 amp 1000 volts	2	3.0			0.50	0.0187	Fuse FU-18-A
FU-22	60 amp. 250 volts	8, 13	3.0			0.812	0.117	Fuse FU-22
INS-1		14, 15, 16	0.25			2.0	0.045	Ceramic ring
INS-2		14, 15, 16	1.81	0.375	0.375		0.020	Ceramic post
INS-3		14, 15, 16	1.25	0.375	1.25		0.049	Ceramic insulator
INS-4		14, 15, 16	1.75	0.375	0.875		0.048	Ceramic insulator
INS-6		14, 15, 16	2.43	0.375	0.875		0.07	Ceramic insulator
INS-7		14, 15, 16	1.25	0.375	0.375		0.014	Ceramic insulator
INS-8		14, 15, 16	0.875	0.375	0.375		0.01	Ceramic insulator
INS-9		14, 15, 16	1.0	0.375	0.375		0.012	Ceramic post
INS-10		14, 15, 16	1.25	0.375	0.375		0.013	Ceramic post
INS-11		14, 15, 16	1.25	0.375	0.375		0.013	Ceramic post
INS-12		14, 15, 16	3.25	3.0	0.375		0.021	Ceramic end plate
INS-13		14, 15, 16	0.875	0.375	0.375		0.01	Ceramic post
INS-14		14, 15, 16	1.0	0.375	0.375		0.012	Ceramic post
INS-17		14, 15, 16			0.25	2.0		Ceramic insulator
J-1		2	1.245	0.937	0.75		0.030	Jack JK-33-A
M-1	500 ma DC	2	2.03			2.56	0.274	Ammeter IS-22 (Plate milliammeter)
M-2	15 volts AC-DC	2	2.03			2.56	0.278	Voltmeter IS-122
M-3	8 amp. RF	2	2.03			2.56	0.400	Ammeter IS-89
M-141	30 amp. 250 volts	2	2.25	0.25	0.010		0.001	Fuse link M-141 for Fuse FU-13
M-168	60 amp., 250 volts	8	3.43	0.375	0.060		0.008	Fuse link M-168 for Fuse FU-22
R-2	2500 ohms, 12 watts	1, 11	3.0			0.750	0.059	Fixed resistor
R-3	4000 ohms, 12 watts	1, 11	3.0			0.750	0.059	Fixed resistor
R-4	200,000 ohms, 1 watt	1, 11	1.25			0.25	0.006	Fixed resistor
R-5	250,000 ohms, 1 watt	1, 11	1.25			0.25	0.006	Fixed resistor
R-8	50 ohms, 4 watts	1, 11	1.75			0.43	0.020	Fixed resistor
R-9	200 ohms, 2 watts	1, 11	0.875			0.43	0.013	Fixed resistor
R-11	11,000 ohms, 12 watts	1, 11	3.0			0.75	0.059	Fixed resistor
R-12	30,000 ohms, 1 watt	1, 11	1.25			0.25	0.006	Fixed resistor

RENEWAL PARTS (Continued)

Spare Part Designation	Electrical Rating	Mfr. Code No.	Dimensions in Inches				Wt. in Lbs.	Description
			Length	Width	Height	Dia.		
R-13	100 ohms, 1 watt	2	5.687	1.375	1.375		0.094	Parasitic resistor and choke
R-14	5 ohms, 2 watts	1, 11	0.875			0.43	0.0143	Fixed resistor
R-15	2.70 ohms, 36 watts 3.70 ohms, 26 watts	2	10.75	2.75	1.93		1.84	Fixed resistor with terminal board
R-16	100 ohms, 12 watts	1	3.0			0.75		Fixed resistor
R-17	5 ohms, 12 watts	1	3.0			0.75		Fixed resistor
R-18	150 ohms, 8 watts	1	2.0			0.75		Fixed resistor
REL-3		2	4.0	2.562	2.75		2.0	Starting relay for dynamotor
REL-4		2	5.625	2.75	2.562		1.36	Antenna switch relay
RFC-1		2			2.84	1.50	0.086	Radio freq. choke and fixed resistor
RFC-2		2			1.45	1.50	0.066	Radio freq. choke
RFC-3		2			1.45	1.187	0.066	Radio freq. choke and fixed resistor
RFC-4		2			1.45	1.187	0.066	Radio freq. choke
RFC-5		2			1.45	1.187	0.066	Radio freq. choke
RFC-6		2			1.45	1.187	0.046	Radio freq. choke
RFC-7		2			1.45	1.06	0.043	Radio freq. choke
RFC-8		2			1.45	1.06	0.063	Radio freq. choke
RFC-9		2			1.45	0.937	0.039	Radio freq. choke
RFC-10		2			1.45	0.937	0.039	Radio freq. choke
RFC-11		2			1.45	0.937	0.038	Radio freq. choke
RFC-12		2			1.45	0.937	0.038	Radio freq. choke
RFC-13		2			2.81	0.625	0.052	Radio freq. choke
RFC-14		2			1.93	1.187	0.054	Radio freq. choke
RFC-15		2			1.45	1.06	0.053	Radio freq. choke
RFC-16		2			1.50	1.453	0.066	Radio freq. choke
RFC-18		2			1.844	1.687	0.092	Radio freq. choke
RFC-20		2	2.344	1.688	2.484			Radio freq. choke and fixed resistor
TR-1		2	4.0	2.625	2.953		2.5	Microphone transformer
TR-3		2	3.75	3.25	4.75		4.81	Modulation transformer
TR-4		2	4.094	2.75	3.188			Interstage transformer
TSK-1		2			1.25	4.0	0.224	Socket for Tube VT-4-C
TSK-2		9	2.25	1.62	0.68		0.0635	Socket for Tube VT-25
VR-1	3000 ohms	7, 12	1.375	1.625	2.0		0.104	Variable resistor
VR-2	200 ohms	7, 12	1.625	1.625	2.0		0.108	Variable resistor

25. LIST OF MANUFACTURERS

Mfr. Code No.	Name and Address
1	IRC International Resistance Co. Philadelphia, Pa.
2	GE General Electric Co. Schenectady, N. Y.
3	CD Cornell-Dubilier Elec. Corp. South Plainfield, N. J.
4	Sprague Specialities Co. North Adams, Mass.
5	Sangamo Elec. Co. Springfield, Ill.
6	Arrow-Hart & Hegeman Elec. Co. Hartford, Conn.
7	P. R. Mallory and Co. Indianapolis, Ind.
8	Bussman Mfg. Co. St. Louis, Mo.
9	Hammarlund Mfg. Co. 424-38 West 33rd St., New York City
10	General Instrument Co. Elizabeth, N. J.
11	Ward Leonard Elec. Co. Mount Vernon, N. Y.
12	Central Radio Laboratories (Centralab) Milwaukee, Wis.
13	Colt-Patent Fire Arms Mfg. Co. Hartford, Conn.
14	Isolantite, Inc. Belleville, N. J.
15	Stupakoff Laboratories, Inc. Latrobe, Pa.
16	American Lava Corp. Chattanooga, Tenn.
17	E. F. Johnson Co. Waseca, Minn.
18	C. P. Clare and Co. Chicago, Ill.

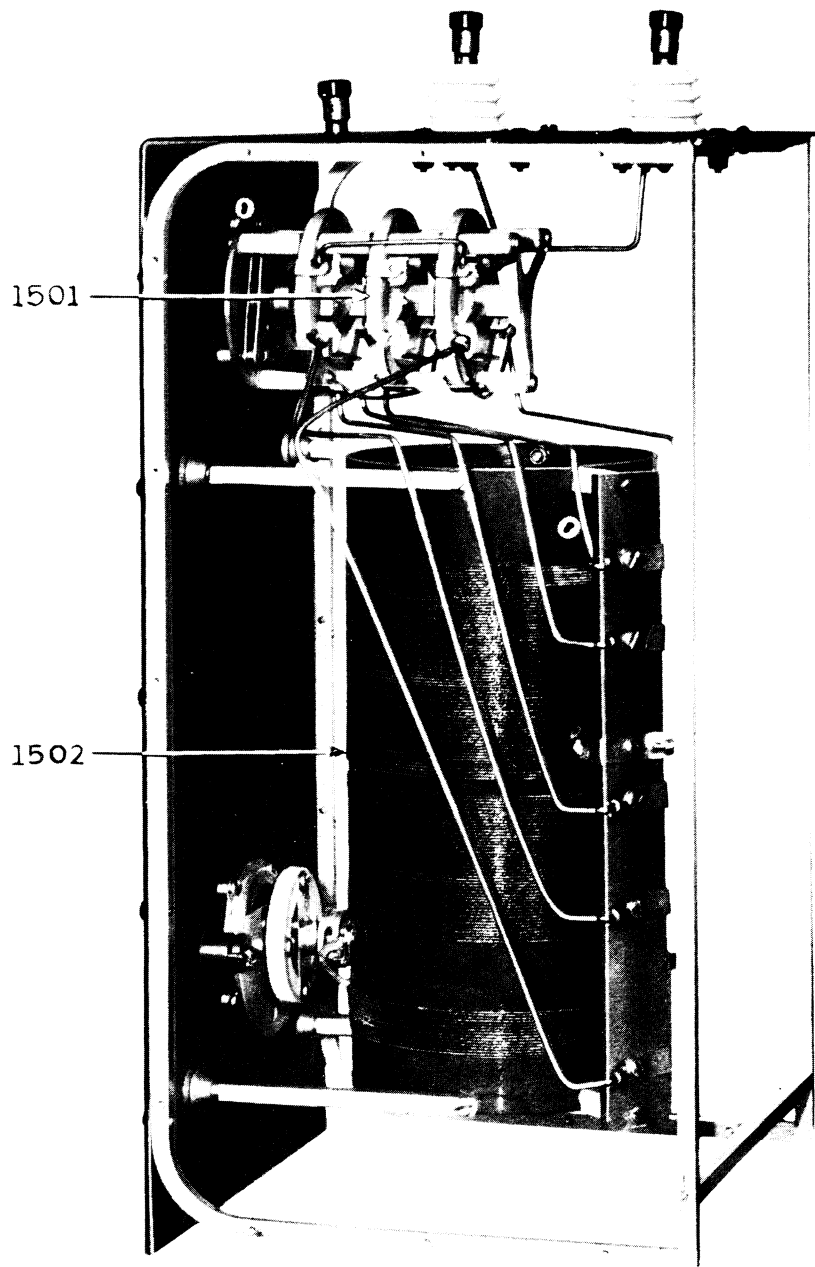

FIGURE 21. ANTENNA TUNING UNIT BC-306-A, INTERIOR VIEW

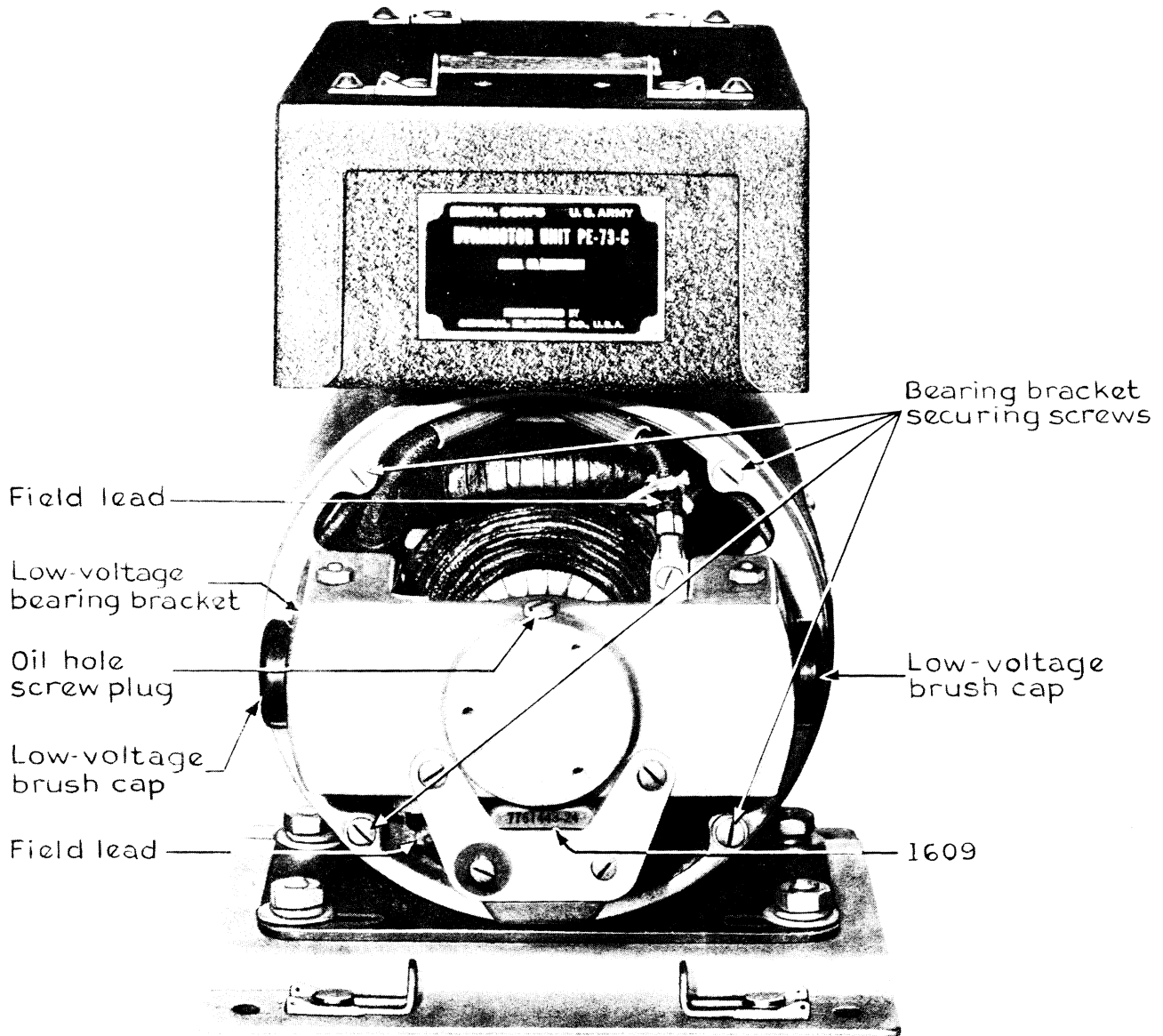

FIGURE 22. DYNAMOTOR UNIT PE-73-C (WITH OIL HOLE AND SCREW PLUG), MOUNTING FT-107 AND LOW-VOLTAGE END BELL REMOVED

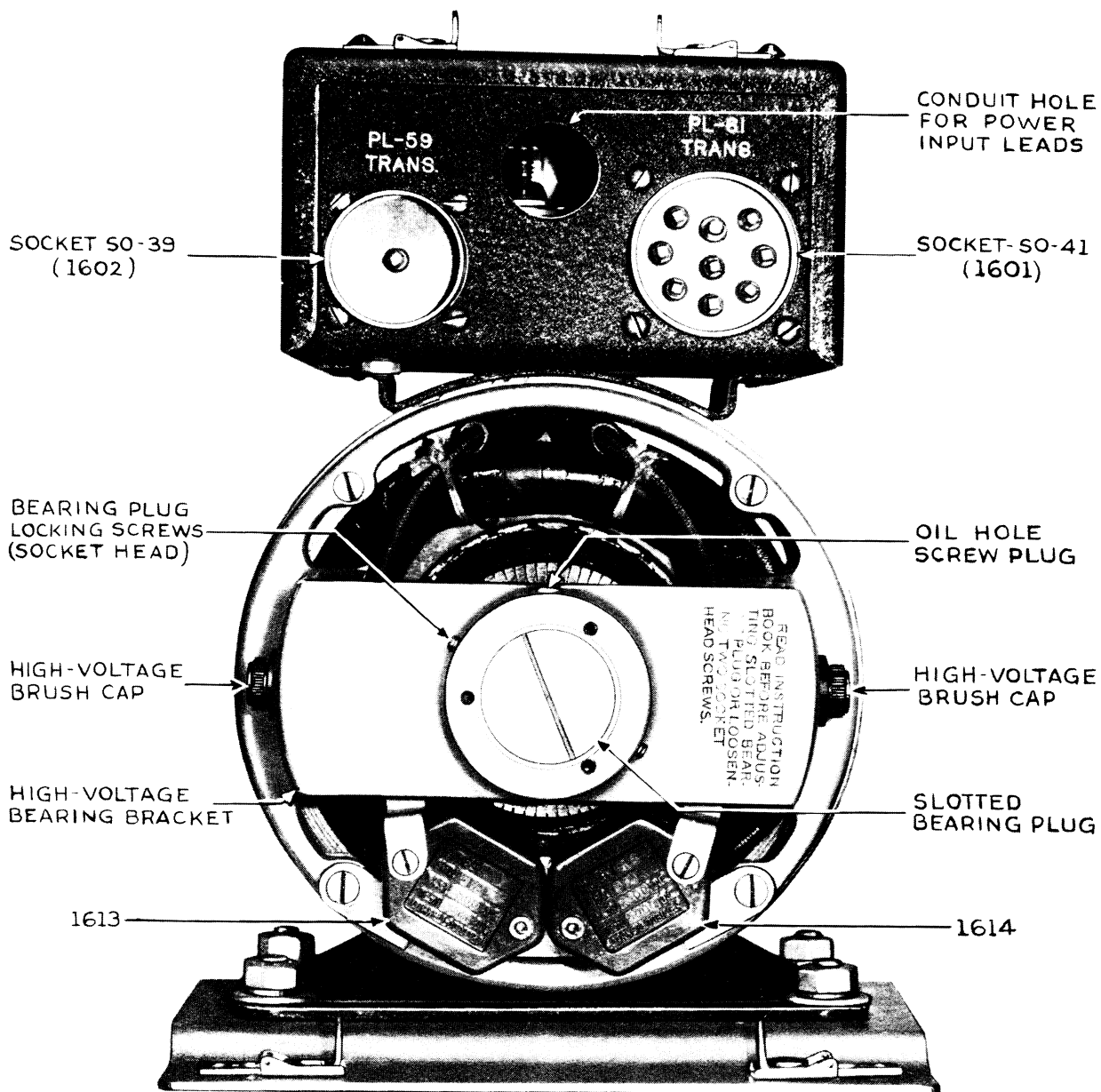

FIGURE 23. DYNAMOTOR UNIT PE-73-C (WITH OIL HOLE AND SCREW PLUG), MOUNTING FT-107 AND HIGH-VOLTAGE END BELL REMOVED

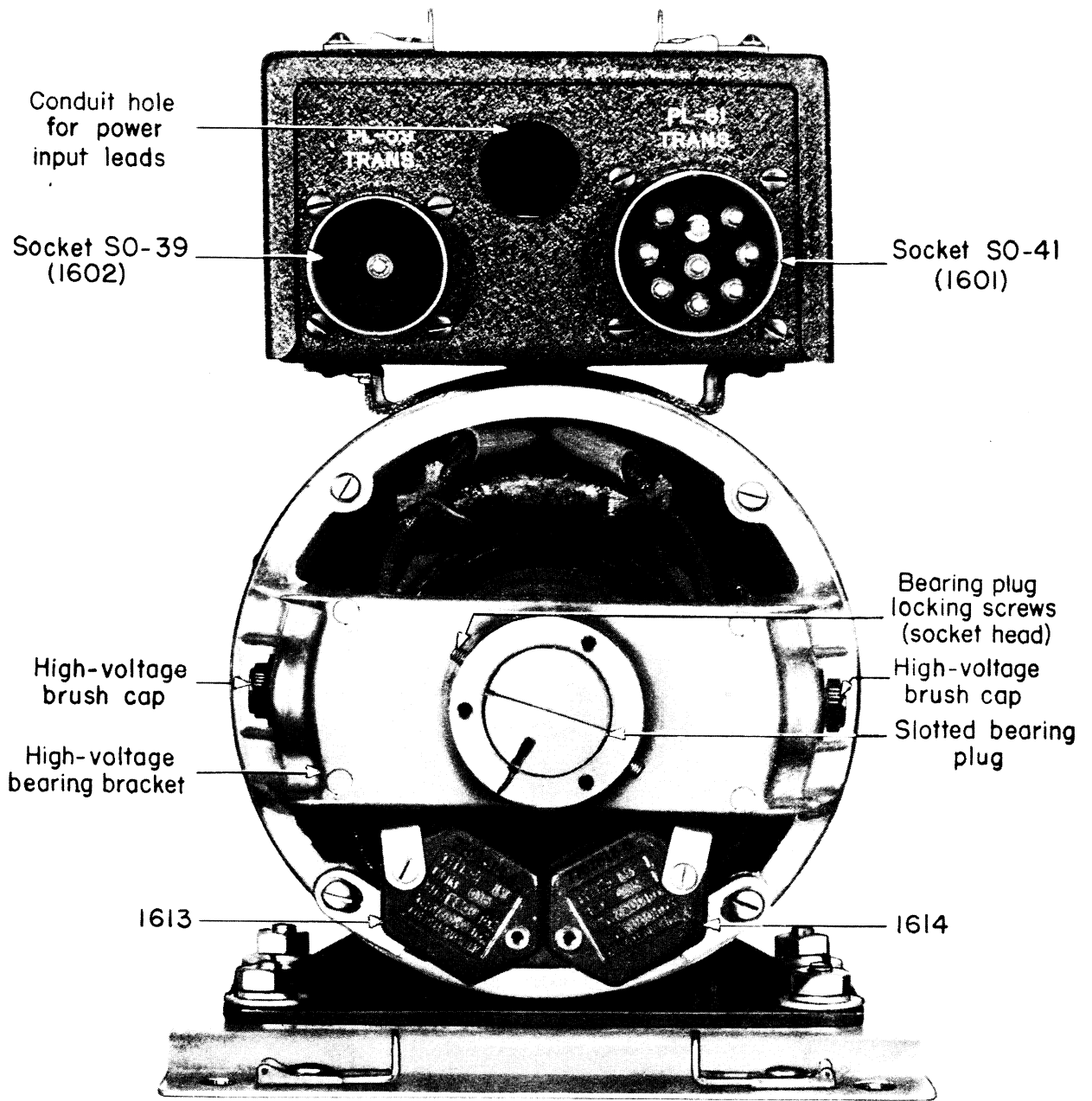

FIGURE 23A. DYNAMOTOR UNIT PE-73-C (WITHOUT OIL HOLE AND SCREW PLUG), MOUNTING FT-107 AND HIGH-VOLTAGE END BELL REMOVED

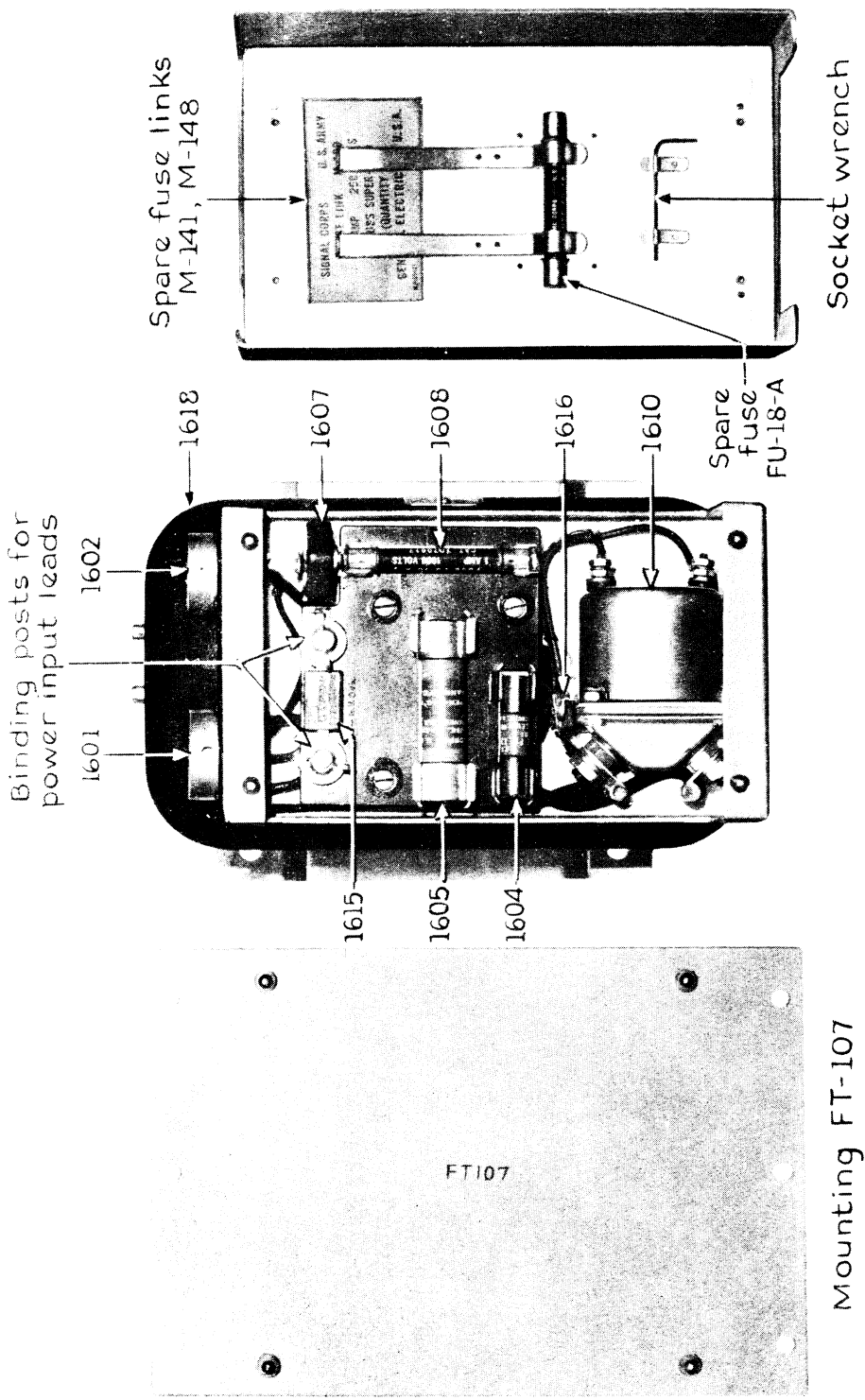

FIGURE 24. DYNAMOTOR UNIT PE-73-C, TOP VIEW, MOUNTING FT-107 AND RELAY-FUSE BOX COVER REMOVED

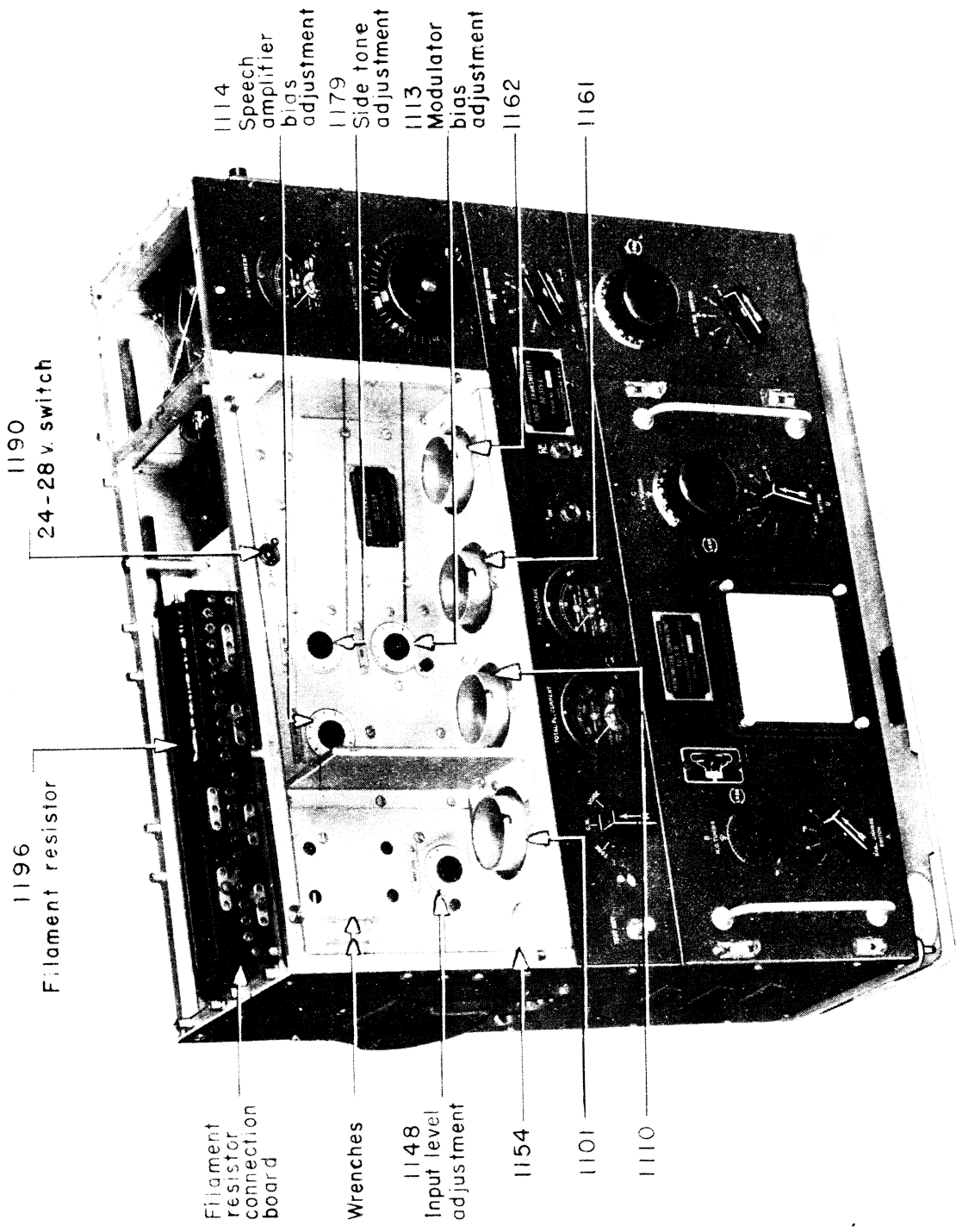

FIGURE 25. RADIO TRANSMITTER BC-375-E, TUBE COMPARTMENT SHIELD AND TOP COVER OFF AND TRANSMITTER TUNING UNIT IN PLACE

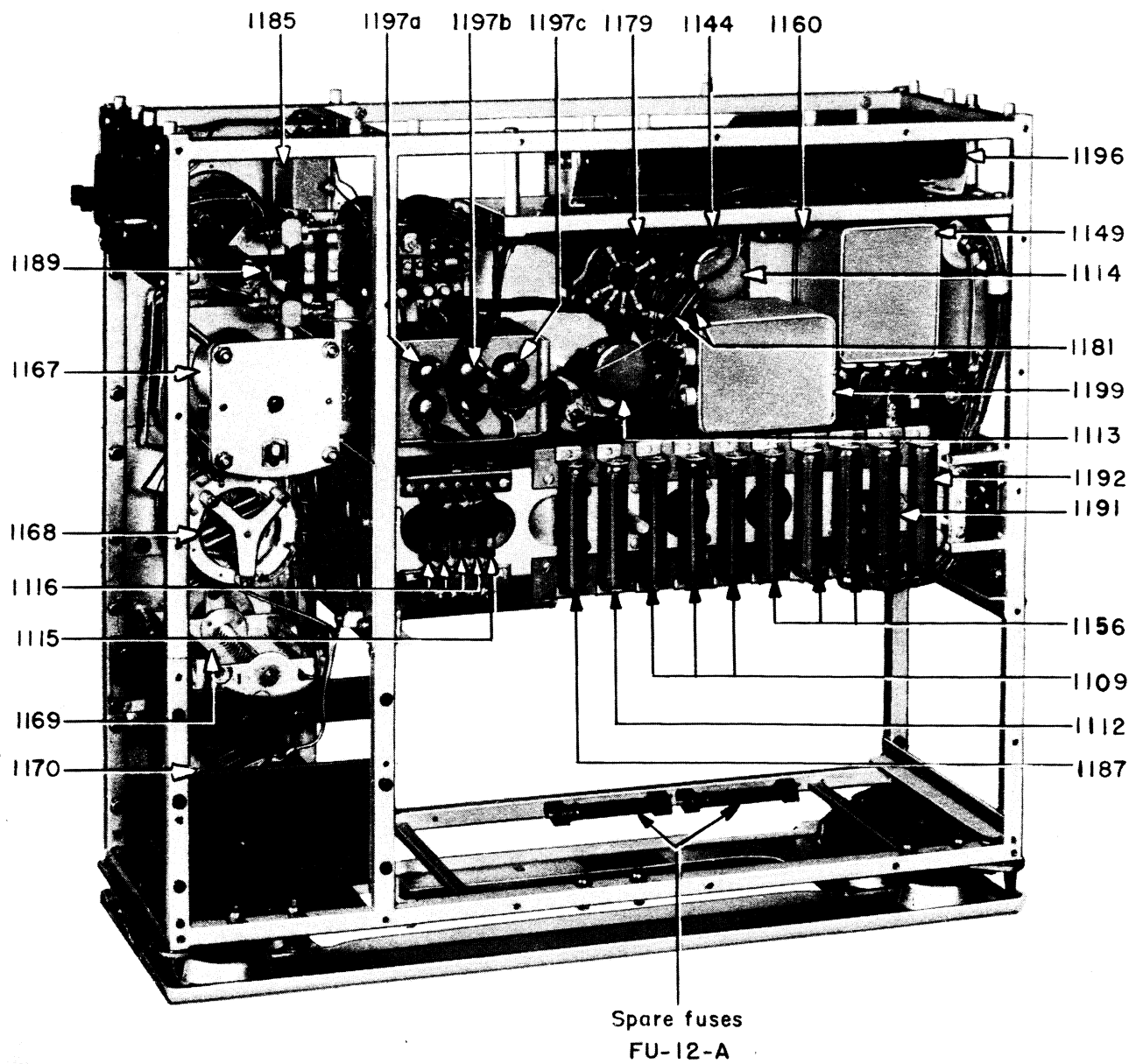

FIGURE 26. RADIO TRANSMITTER BC-375-E, LEFT REAR VIEW, WITH SHIELDS REMOVED, AND WITH MOUNTING FT-151-A

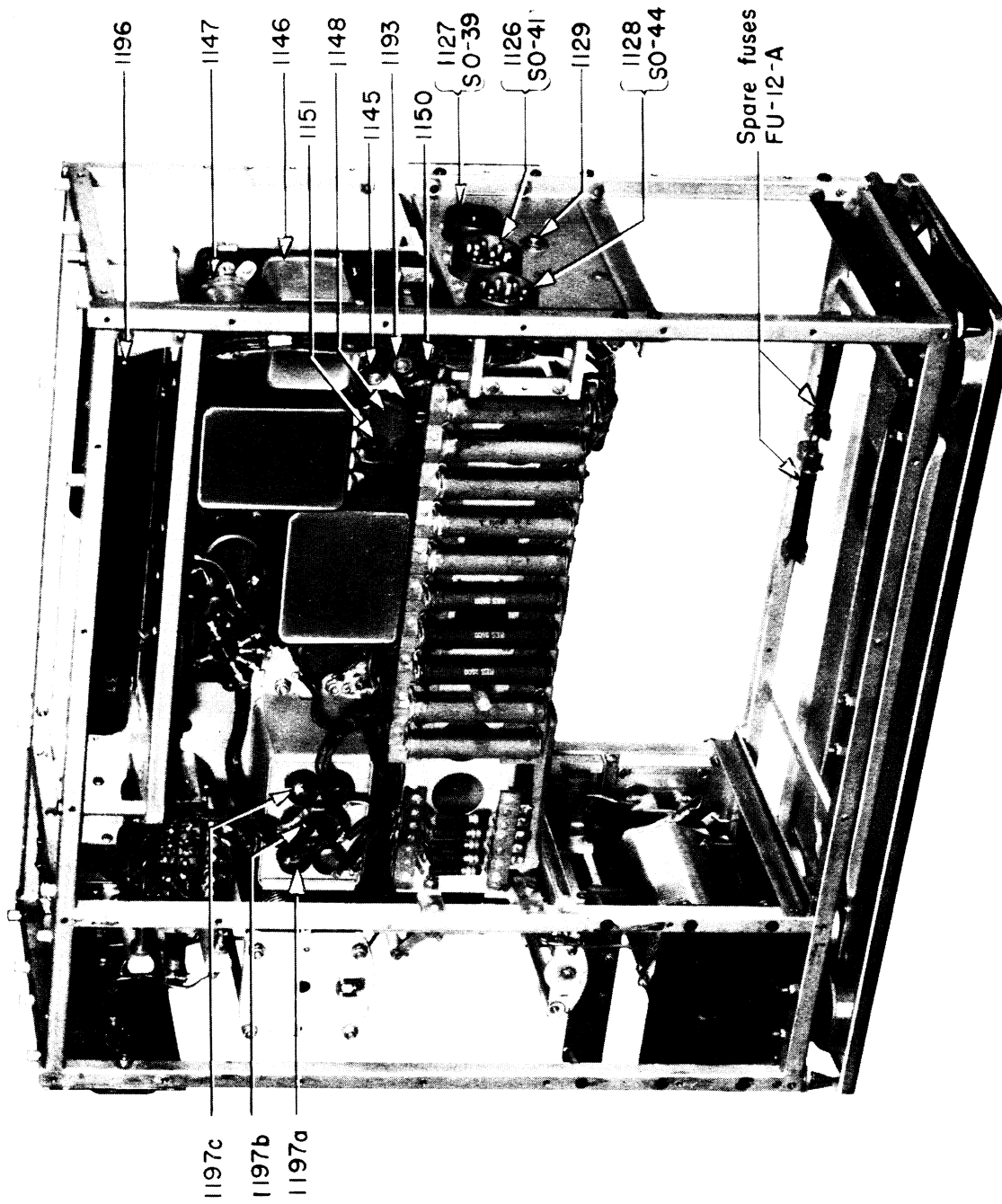

FIGURE 27. RADIO TRANSMITTER BC-375-E, RIGHT REAR VIEW, WITH SHIELDS REMOVED, AND WITH MOUNTING FT-151-A

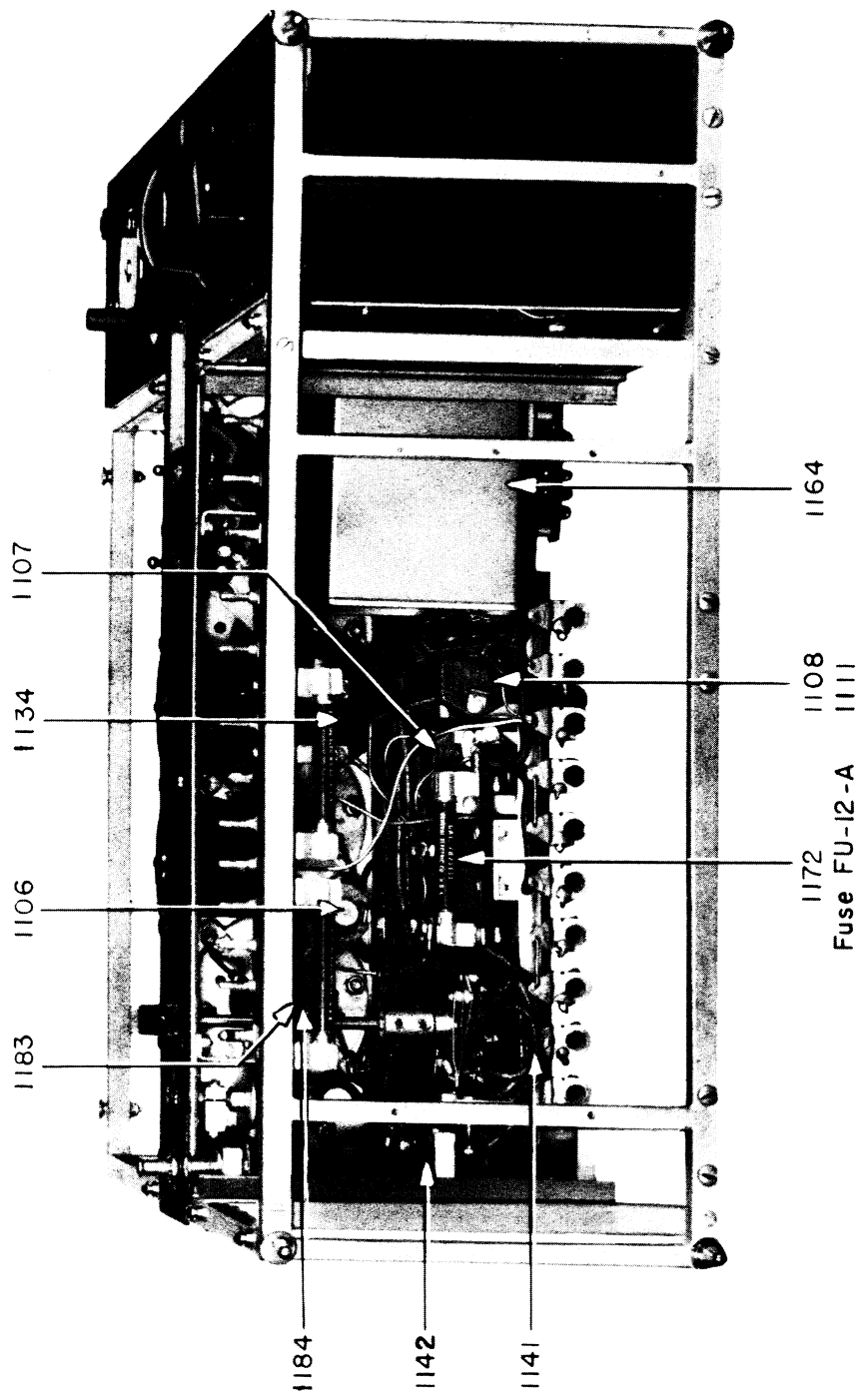

FIGURE 28. RADIO TRANSMITTER BC-375-E, BOTTOM VIEW, MOUNTING FT-151-A AND SHIELDS REMOVED

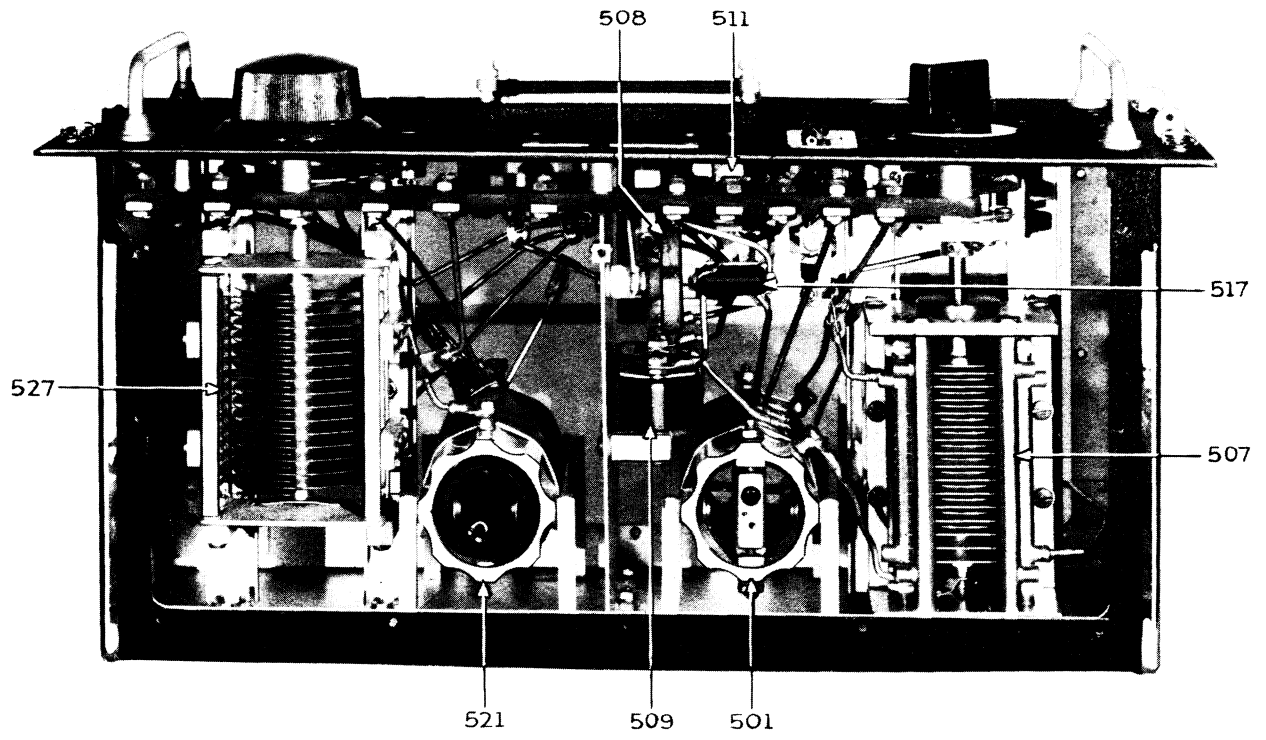

FIGURE 29. TRANSMITTER TUNING UNIT TU-5-B, TOP VIEW, COVER REMOVED

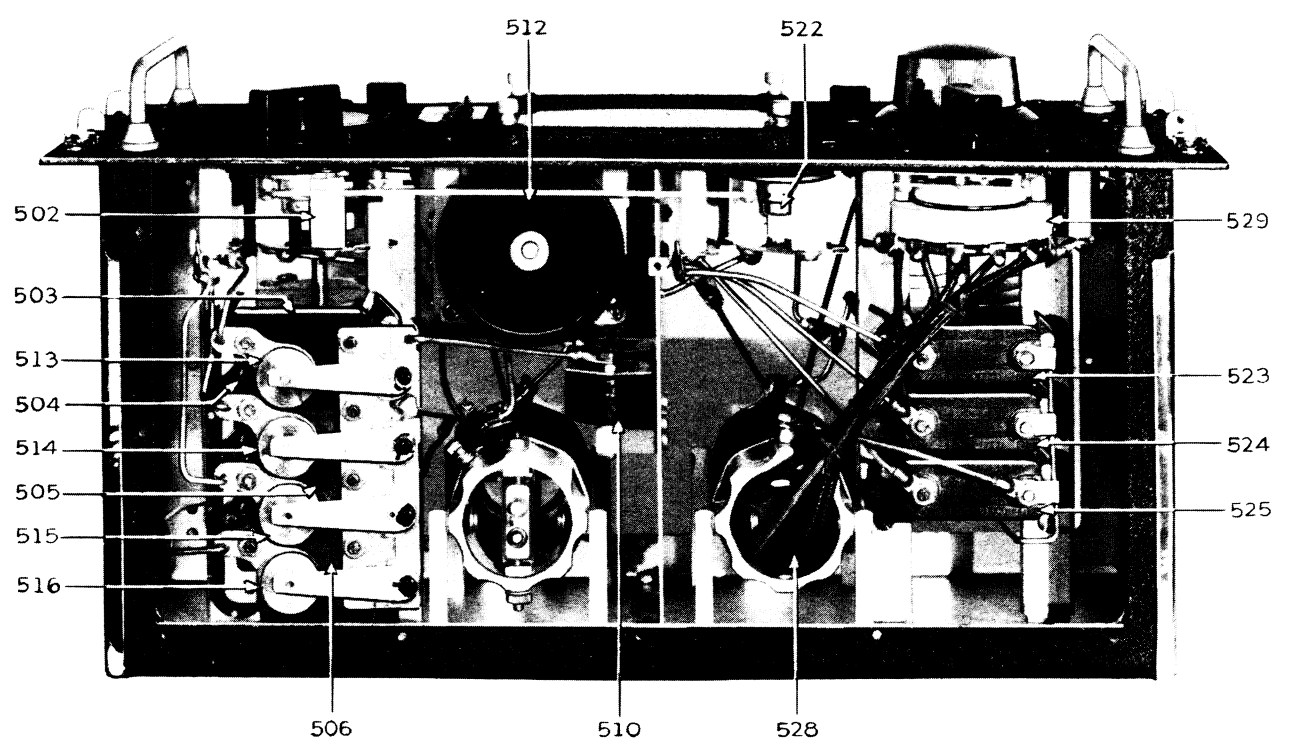

FIGURE 30. TRANSMITTER TUNING UNIT TU-5-B, BOTTOM VIEW, COVER REMOVED

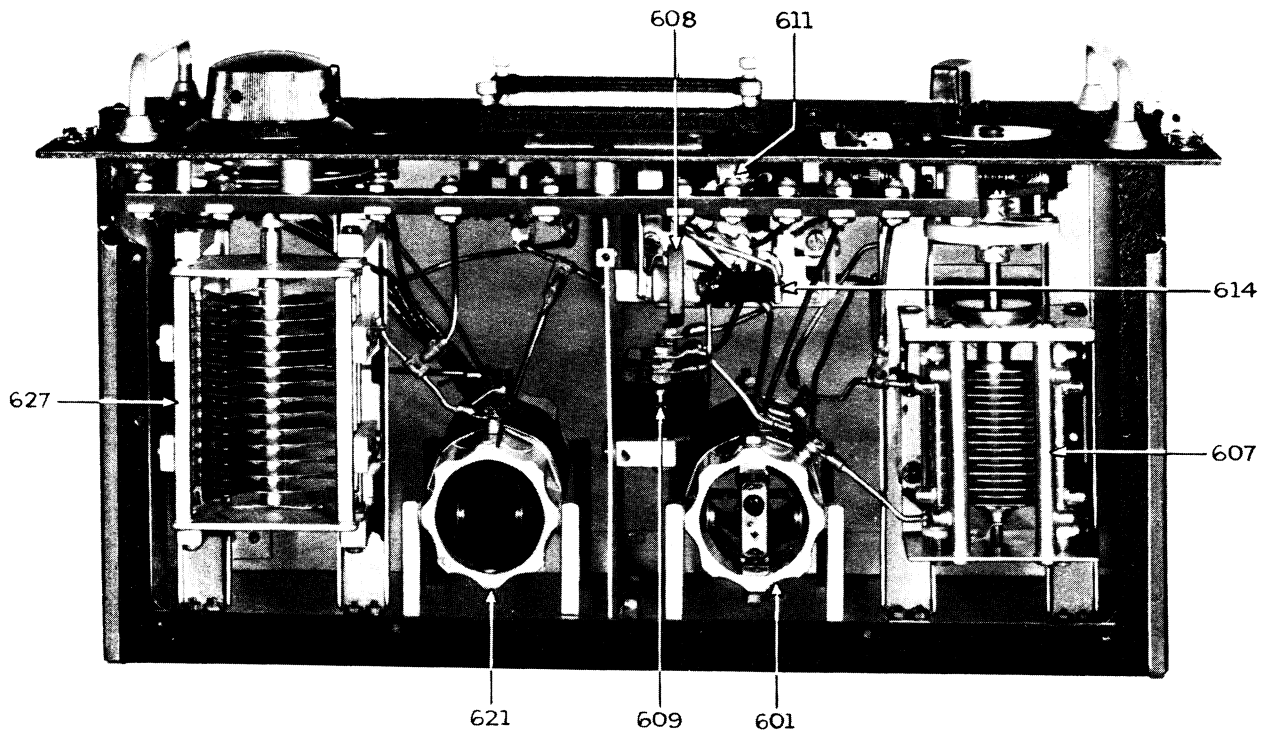

FIGURE 31. TRANSMITTER TUNING UNIT TU-6-B, TOP VIEW, COVER REMOVED

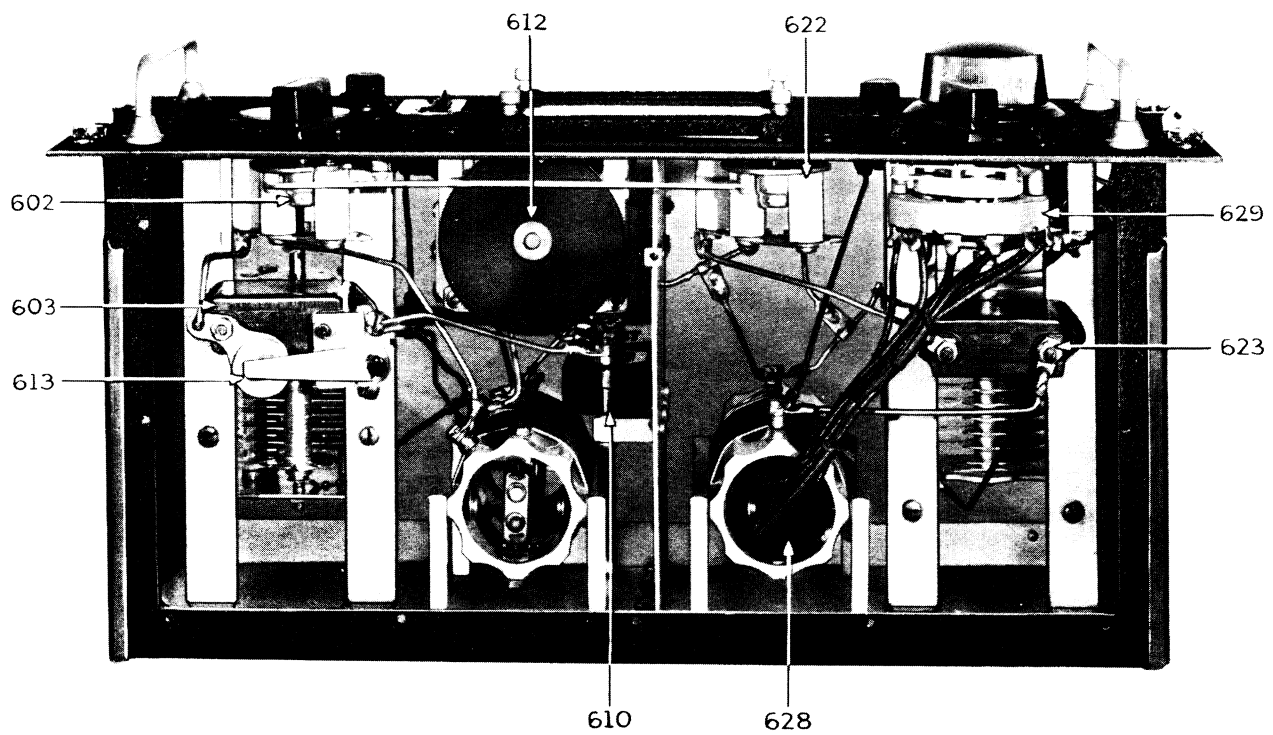

FIGURE 32. TRANSMITTER TUNING UNIT TU-6-B, BOTTOM VIEW, COVER REMOVED

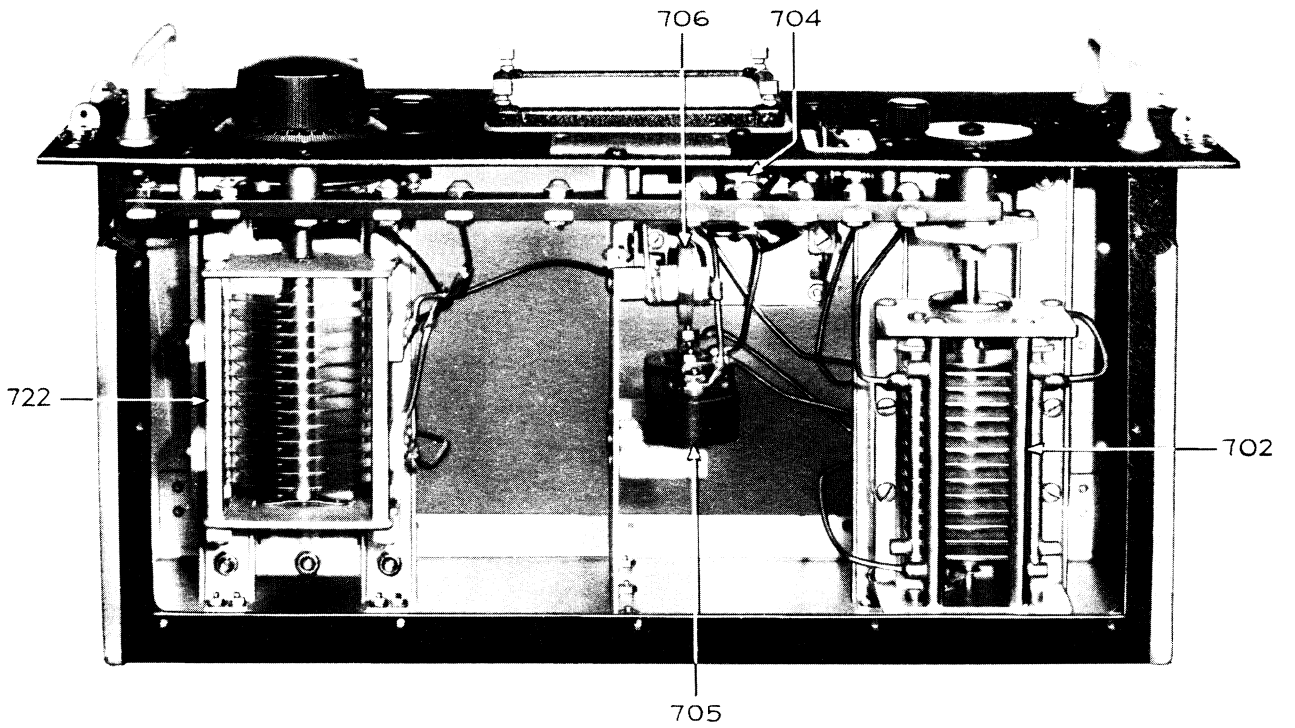

FIGURE 33. TRANSMITTER TUNING UNIT TU-7-B, TOP VIEW, COVER REMOVED

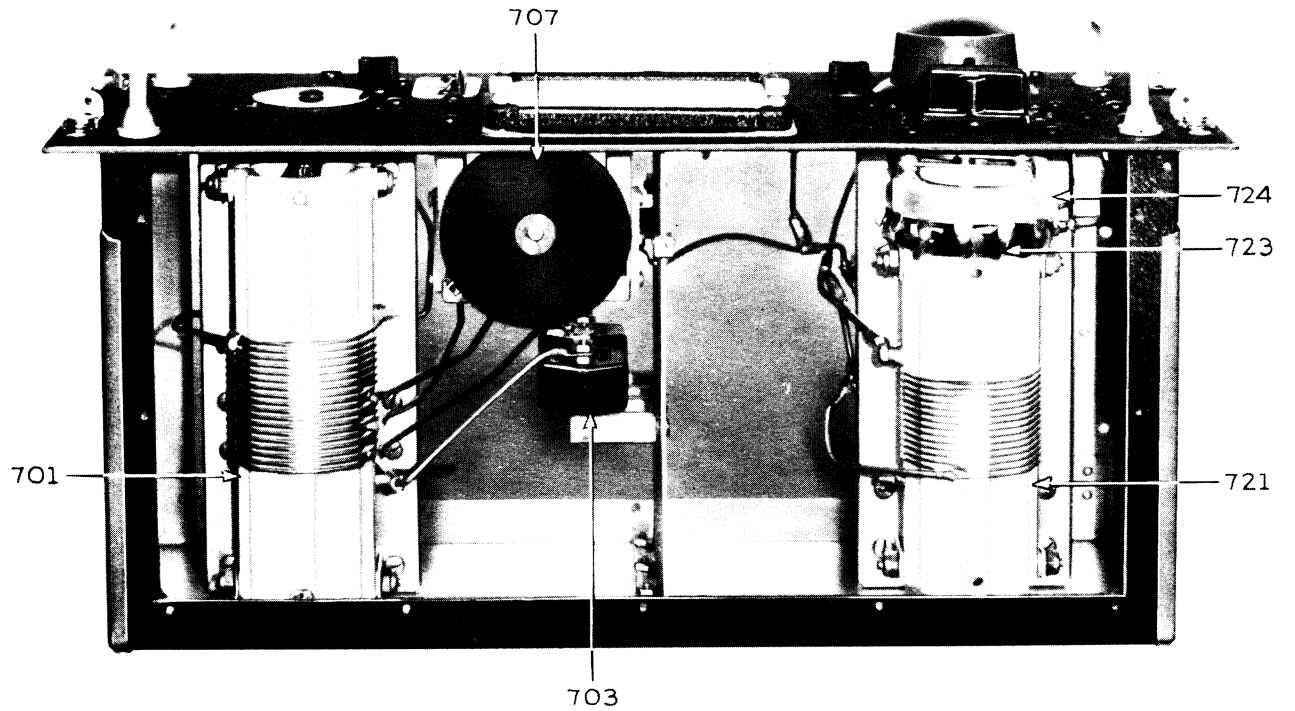

FIGURE 34. TRANSMITTER TUNING UNIT TU-7-B, BOTTOM VIEW, COVER REMOVED

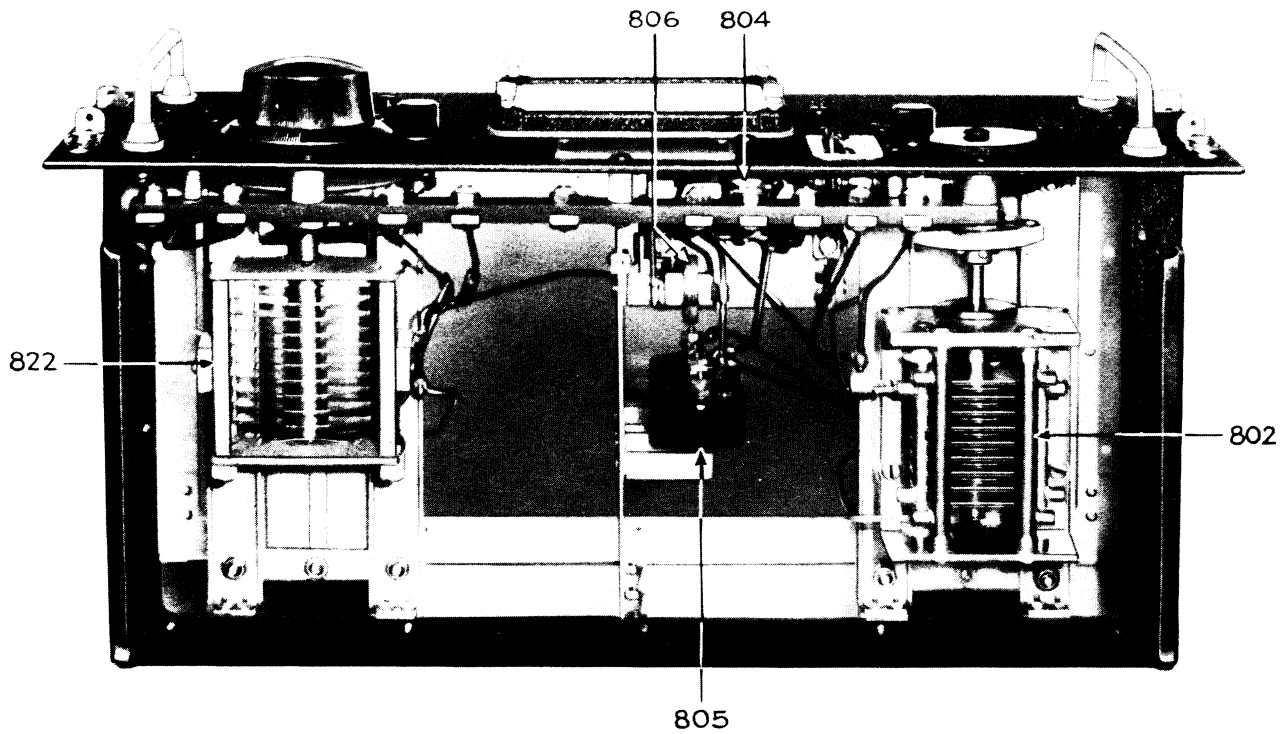

FIGURE 35. TRANSMITTER TUNING UNIT TU-8-B, TOP VIEW, COVER REMOVED

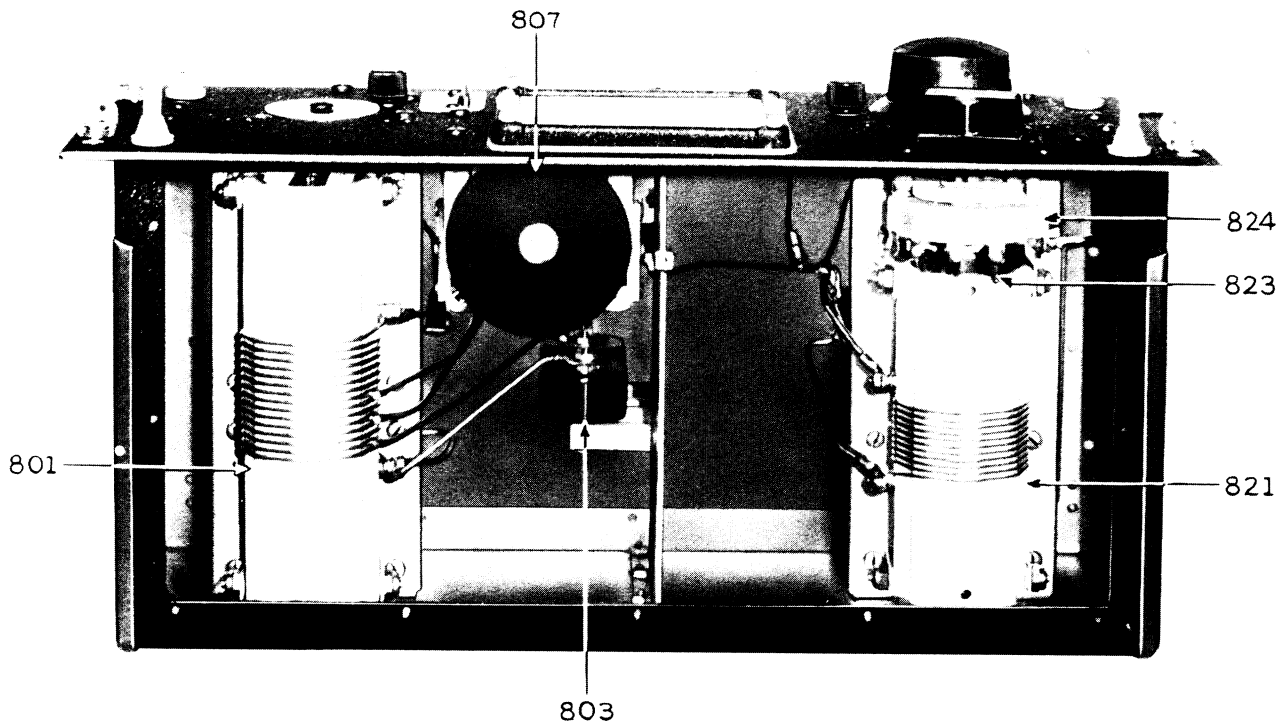

FIGURE 36. TRANSMITTER TUNING UNIT TU-8-B, BOTTOM VIEW, COVER REMOVED

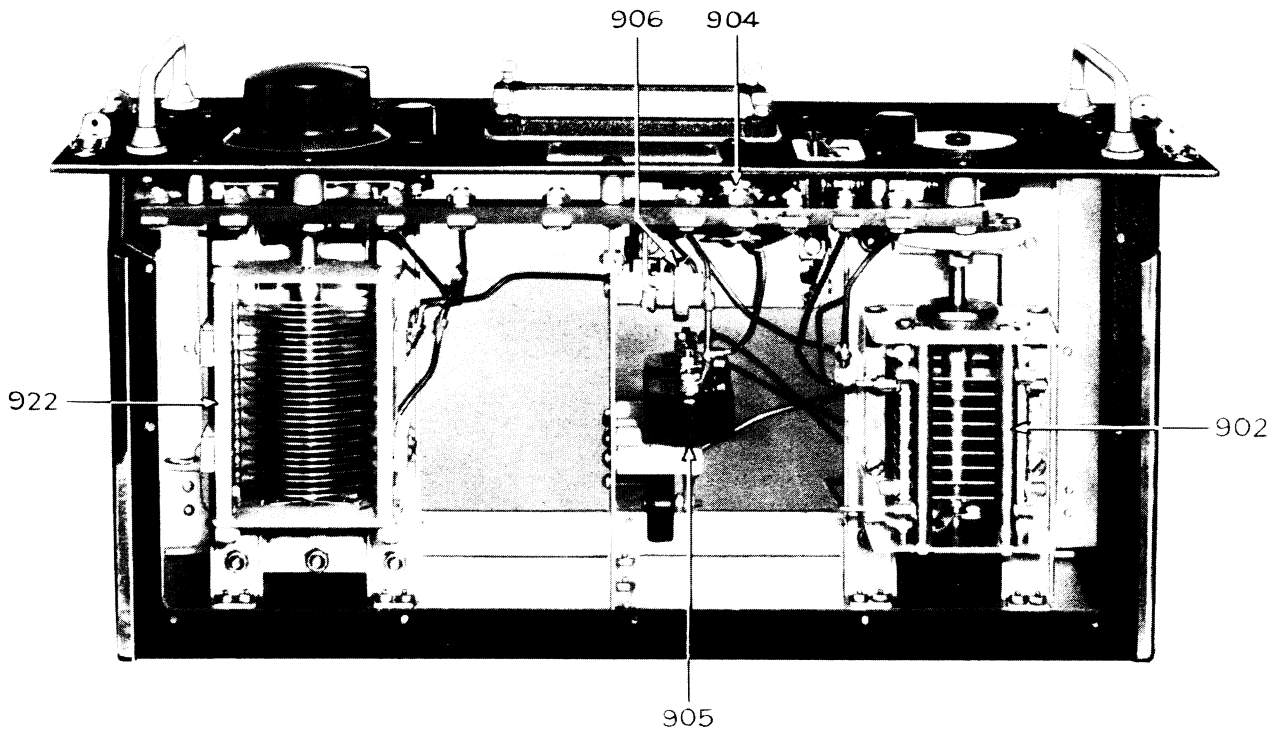

FIGURE 37. TRANSMITTER TUNING UNIT TU-9-B, TOP VIEW, COVER REMOVED

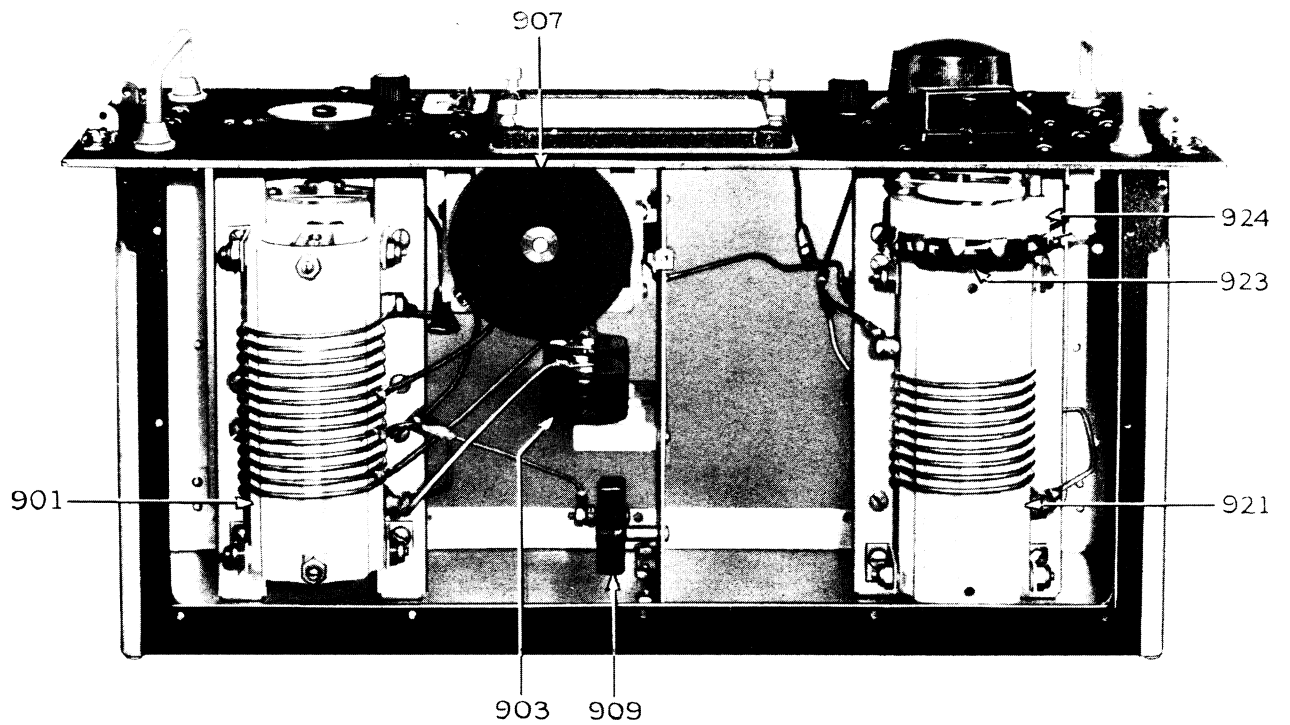

FIGURE 38. TRANSMITTER TUNING UNIT TU-9-B, BOTTOM VIEW, COVER REMOVED

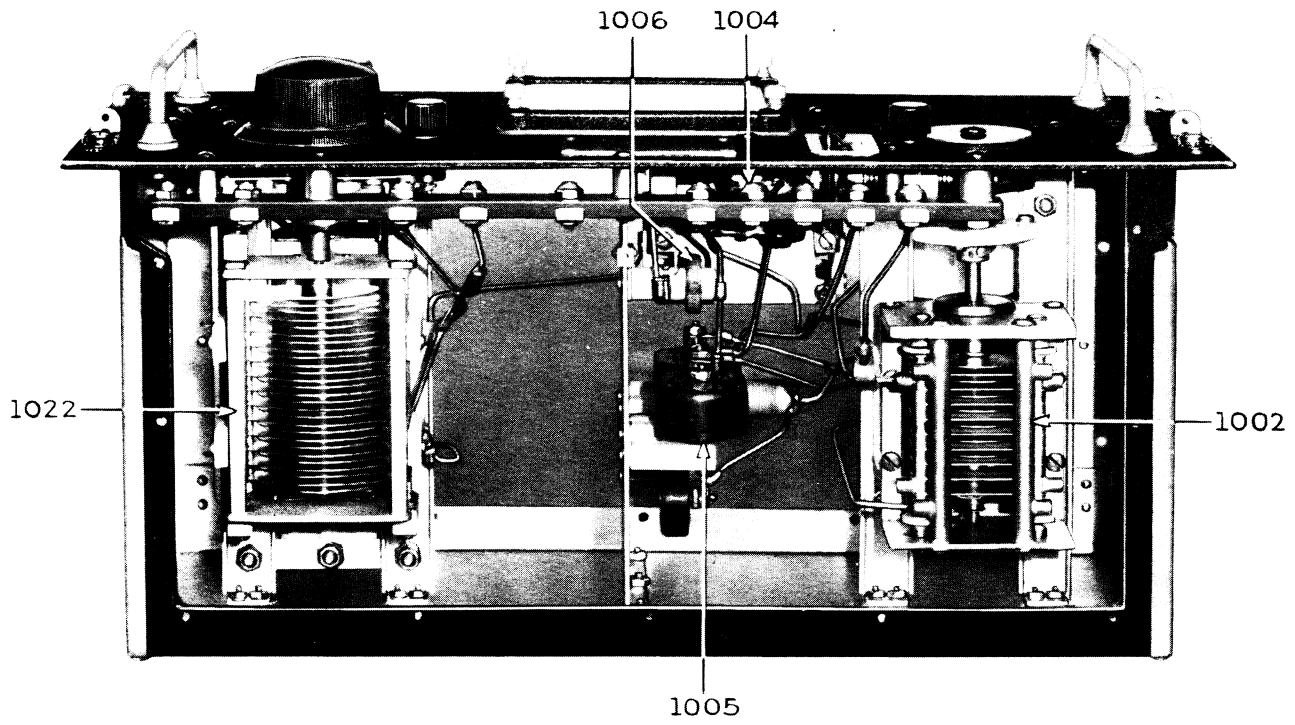

FIGURE 39. TRANSMITTER TUNING UNIT TU-10-B, TOP VIEW, COVER REMOVED

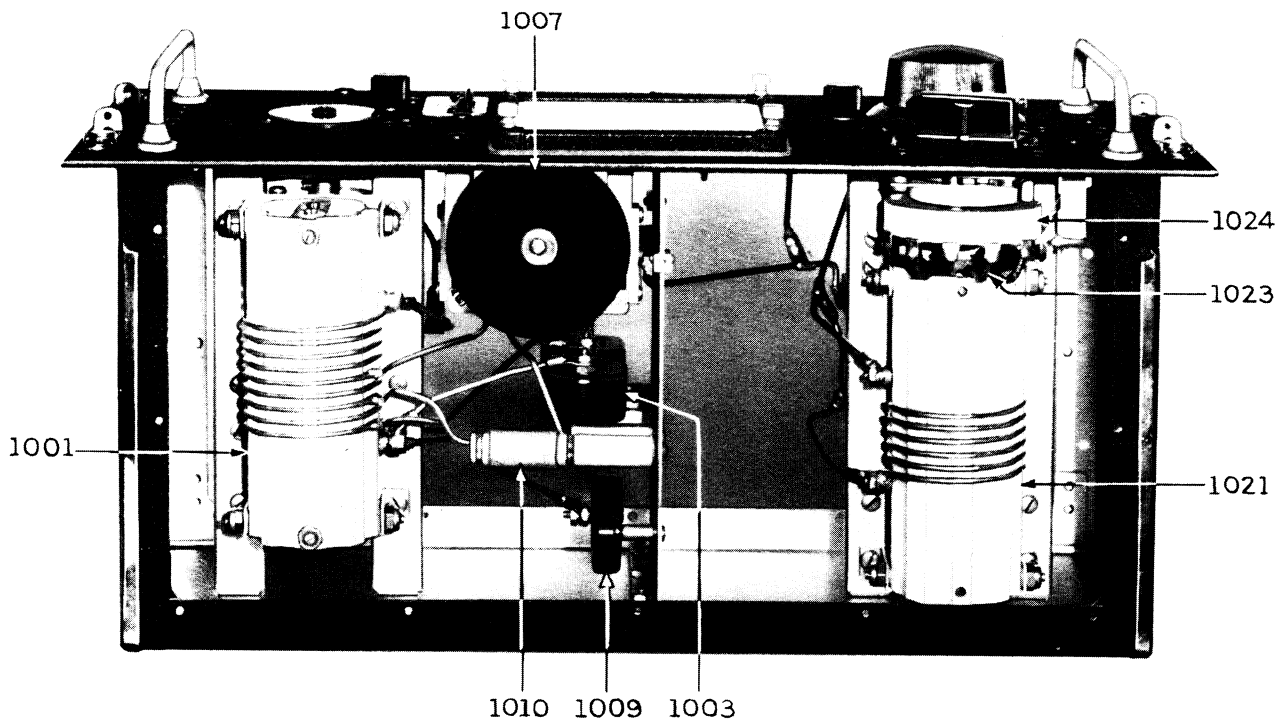

FIGURE 40. TRANSMITTER TUNING UNIT TU-10-B, BOTTOM VIEW, COVER REMOVED

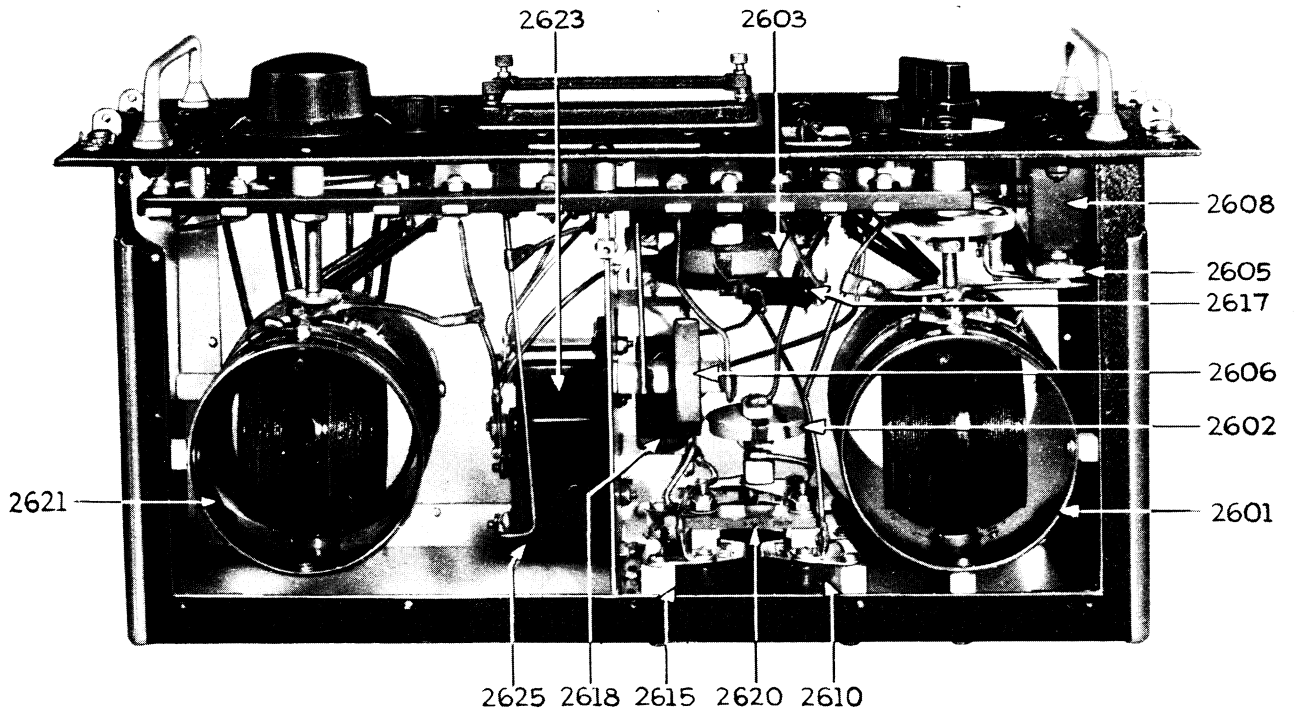

FIGURE 41. TRANSMITTER TUNING UNIT TU-26-B, TOP VIEW, COVER REMOVED

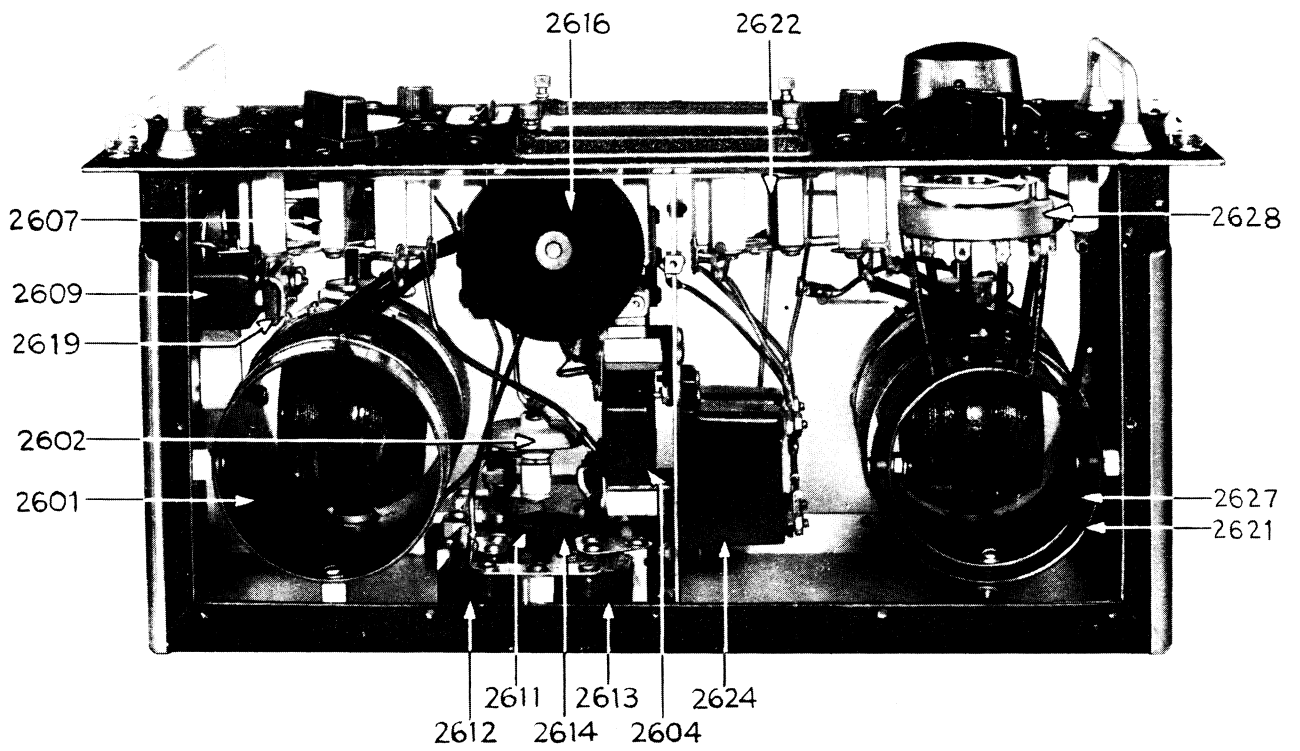
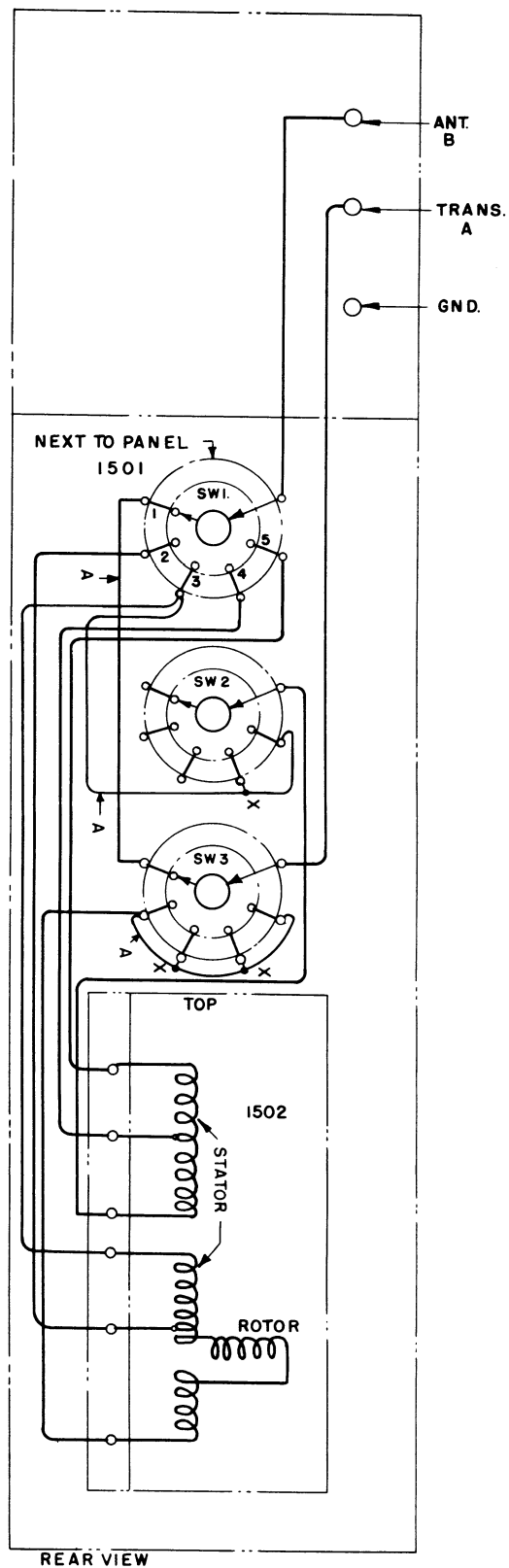

FIGURE 42. TRANSMITTER TUNING UNIT TU-26-B, BOTTOM VIEW, COVER REMOVED



CONNECTION	SIZE OF CONDUCTOR
UNMARKED	.102" DIA. COPPER WIRE TINNED
A	.080" DIA. COPPER WIRE TINNED

AT POINTS MARKED "X" USE COTTER PIN $\frac{1}{16}$ " x $\frac{3}{8}$ "

FIGURE 43. ANTENNA TUNING UNIT BC-306-A, CONNECTION DIAGRAM

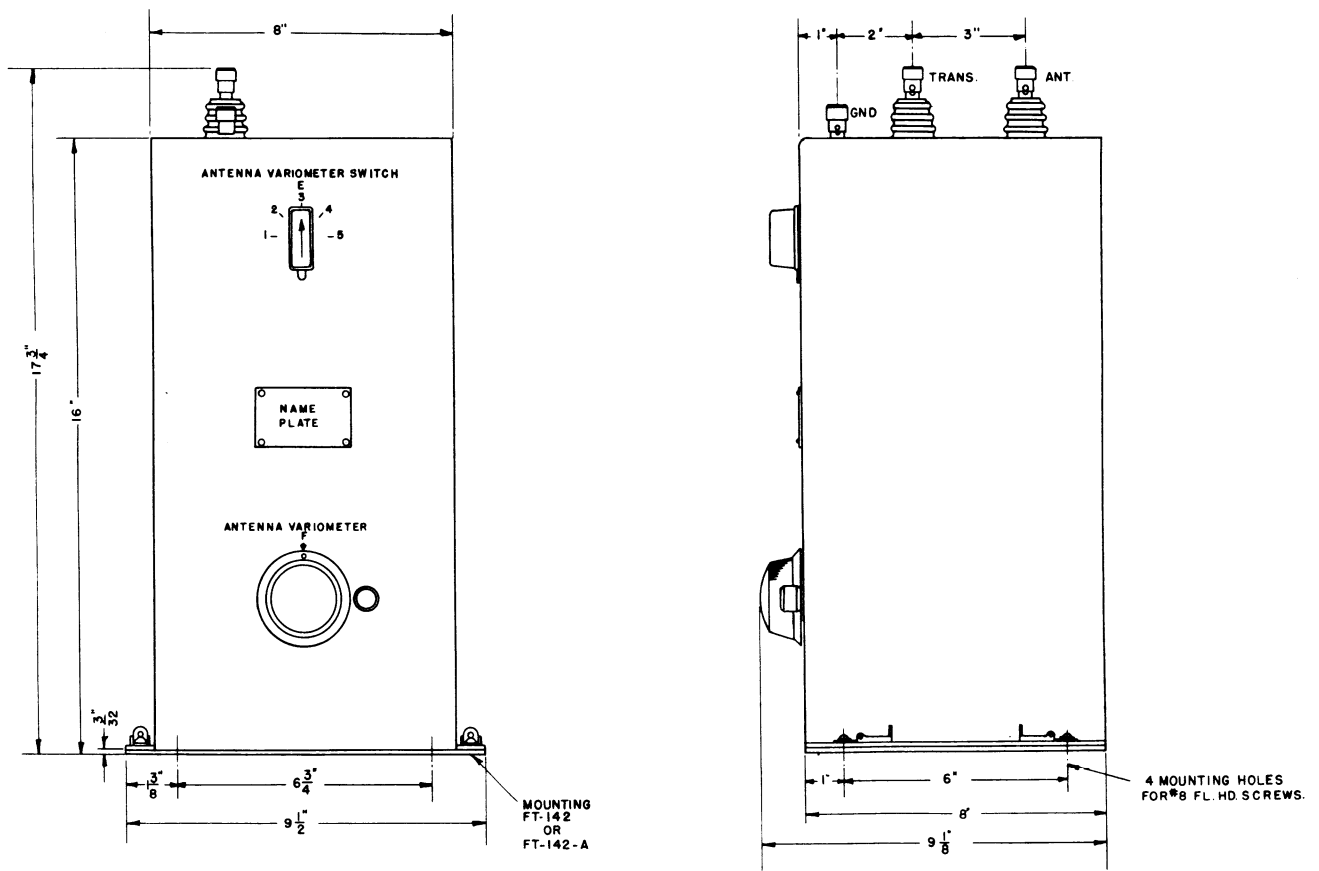

Weight of Antenna Tuning Unit
 BC-306-A Less Mounting FT-142 .. 9.062 lb
 Weight of Mounting FT-142 0.687 lb

FIGURE 44. ANTENNA TUNING UNIT BC-306-A, OUTLINE DIMENSIONAL SKETCH

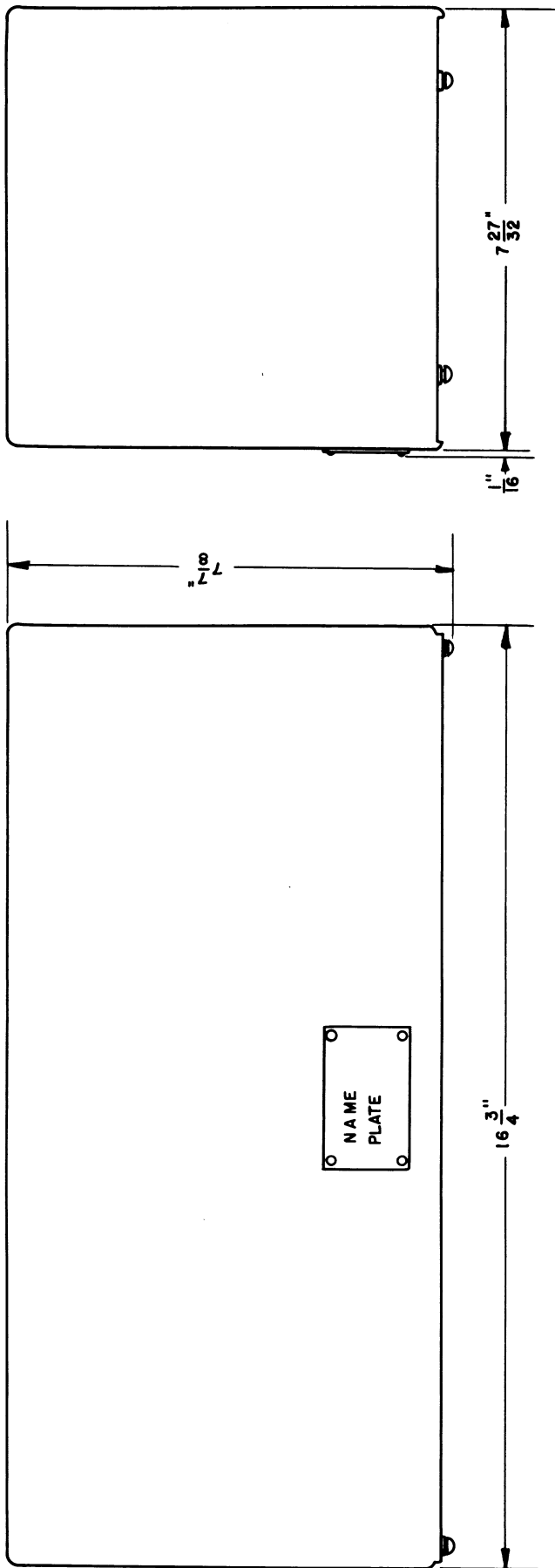

Weight of Case CS-48 4.375 lb

FIGURE 45. CASE CS-48, OUTLINE DIMENSIONAL SKETCH

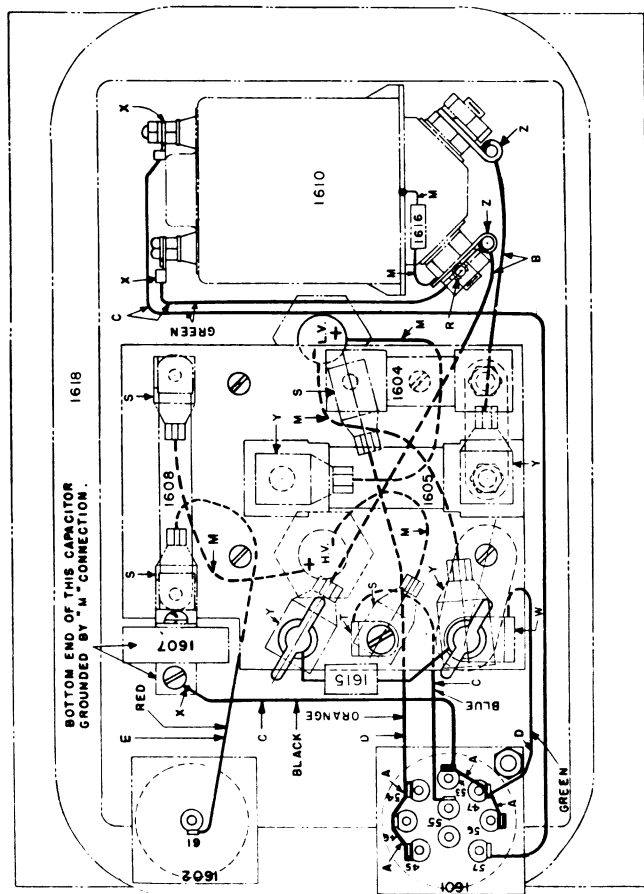

NOTE: - CUT ALL LEADS TO PROPER LENGTH SUCH THAT THEY MAKE THE POSITIONS SHOWN IN CONNECTION DIAGRAM WHEN TERMINAL BOARD IS SECURED IN PLACE.

TO PREVENT EXTERNAL BRAID OF "B" CONNECTIONS FROM FRAYING ASSEMBLE CAP K-7876391 TO RELAY END OF EACH LEAD BEFORE SOLDERING TO TERMINAL.
REMOVE METAL IDENTIFICATION TAGS FROM THE FOUR DYNAMOTOR LEADS AFTER CONNECTIONS ARE MADE.

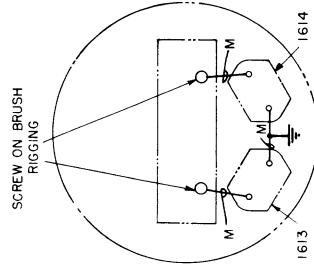

HIGH VOLTAGE
END OF DYNAMOTOR

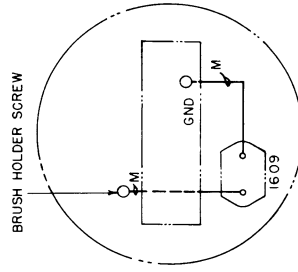

LOW VOLTAGE
END OF DYNAMOTOR

CONNECTION	SIZE OF CONDUCTOR	CONNECTION	TERMINAL
A	.041" DIA. COPPER WIRE TINNED	X	K-7872831
B	# 8 AWG. S. I. 12249 (BLACK)	Y	V-416575
C	# 16 AWG. 14 RUBBER INSULATION K-7872345	Z	K-7870985 PT-2
D	# 14 AWG. 14 RUBBER INSULATION K-7872345	W	V-1448899 "O". 3L
M	UNIT PIECE OF APPARATUS	S	V-417591
E	# 16 AWG. 14 RUBBER INSULATION (RED) K-7872345, PT. II.	T	V-450858
		R	K-7875573

FIGURE 46. DYNAMOTOR UNIT PE-73-C, CONNECTION DIAGRAM

(

(

(

(

(

TYPICAL TRANSMITTER TUNING UNIT TU-8-B

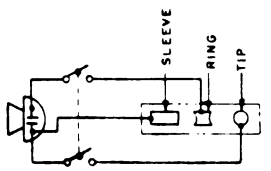
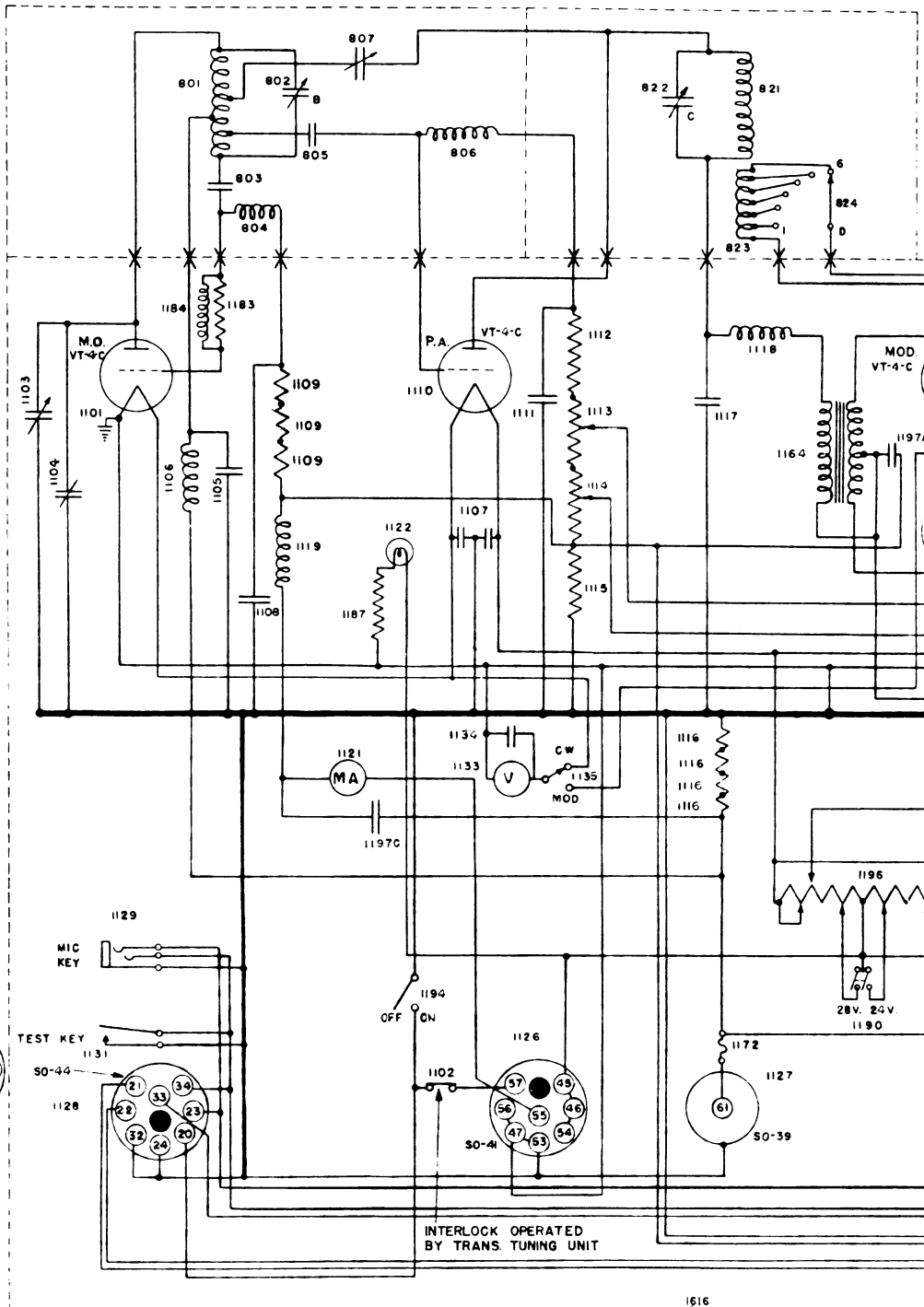

MICROPHONE CONNECTIONS

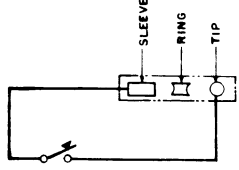

KEY CONNECTIONS

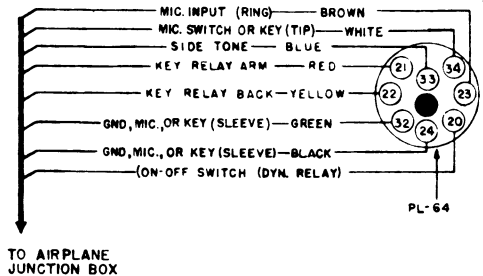

TO AIRPLANE JUNCTION BOX

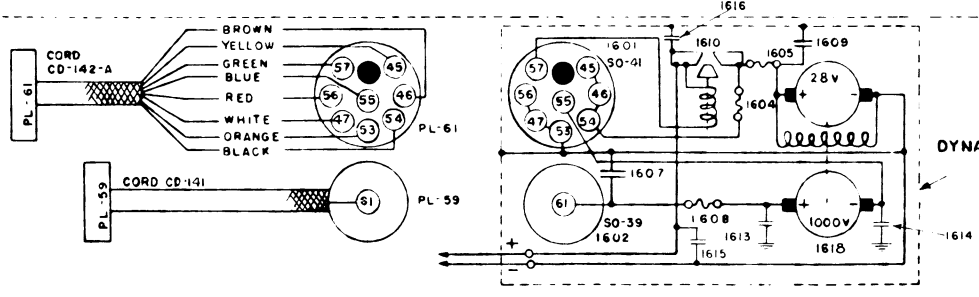

TO PRIMARY POWER SUPPLY 28 VOLTS DC

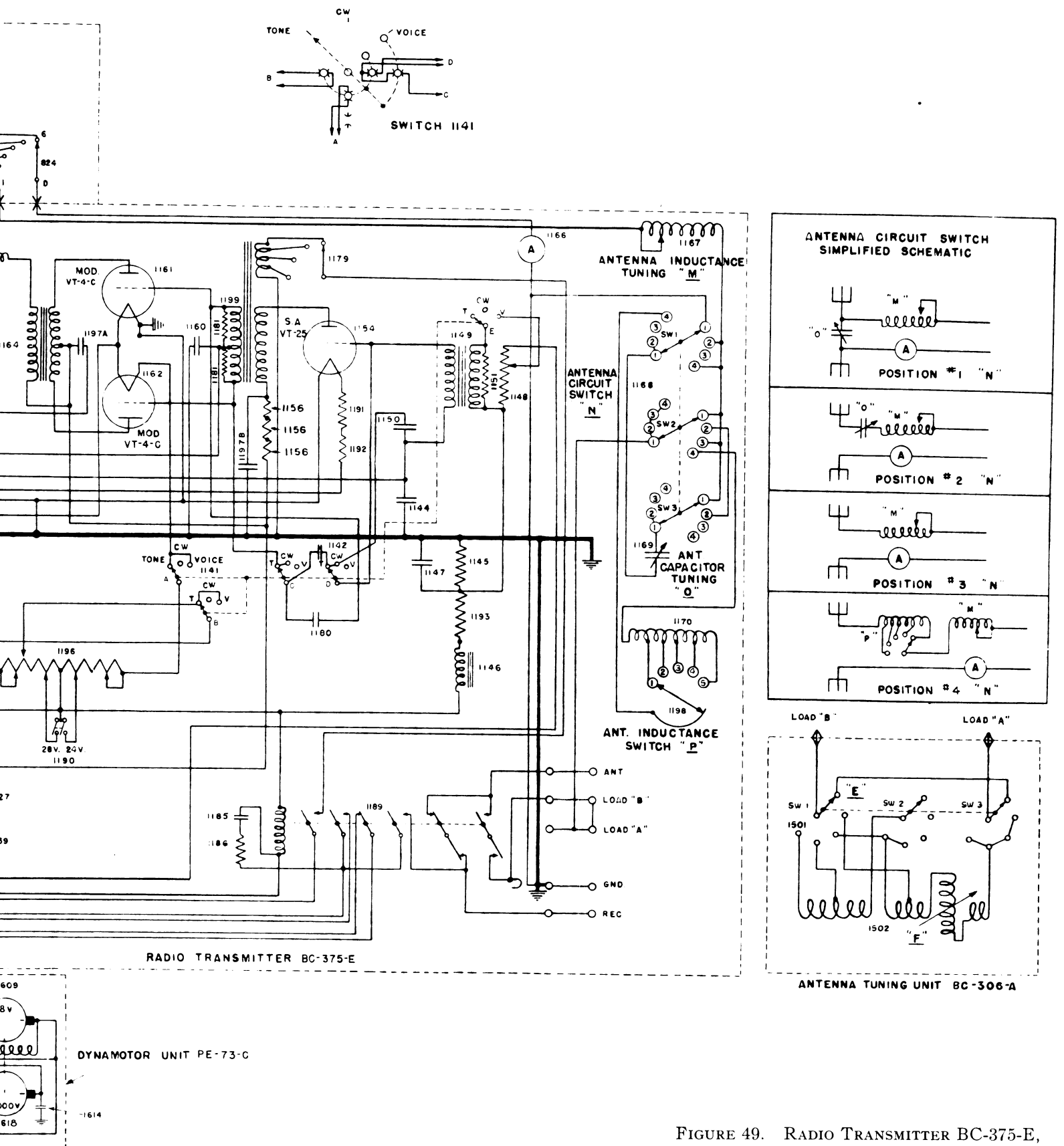
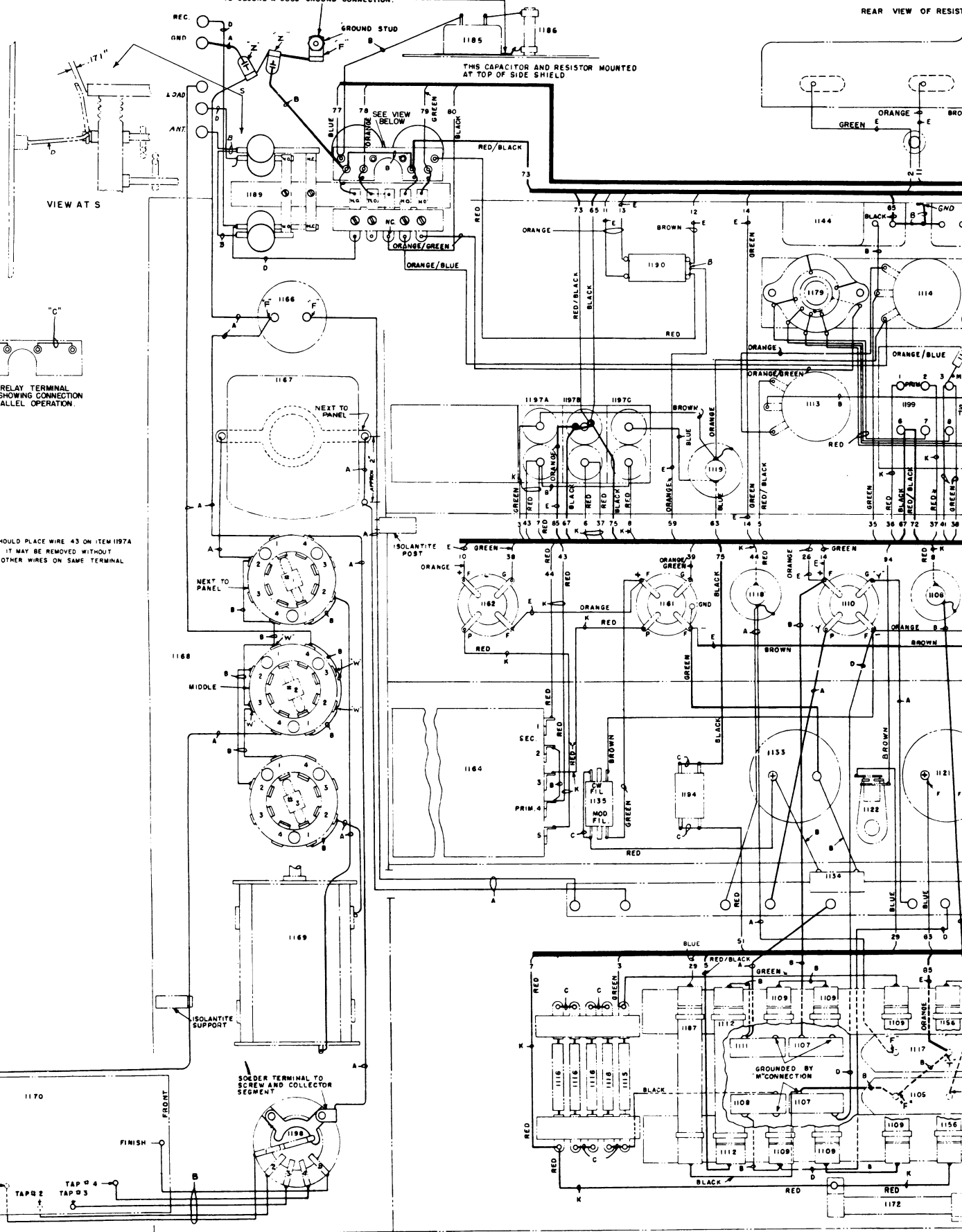

FIGURE 49. RADIO TRANSMITTER BC-375-E, SCHEMATIC DIAGRAM

SPOT SURFACE OF SHIELD AT THIS POINT TO SECURE A GOOD GROUND CONNECTION.

REAR VIEW OF RESISTOR



VIEW AT S

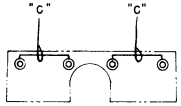

VIEW OF RELAY TERMINAL BOARD SHOWING CONNECTION FOR PARALLEL OPERATION.

NOTE:
WIREMAN SHOULD PLACE WIRE 43 ON ITEM 1197A SUCH THAT IT MAY BE REMOVED WITHOUT REMOVING OTHER WIRES ON SAME TERMINAL

REAR VIEW

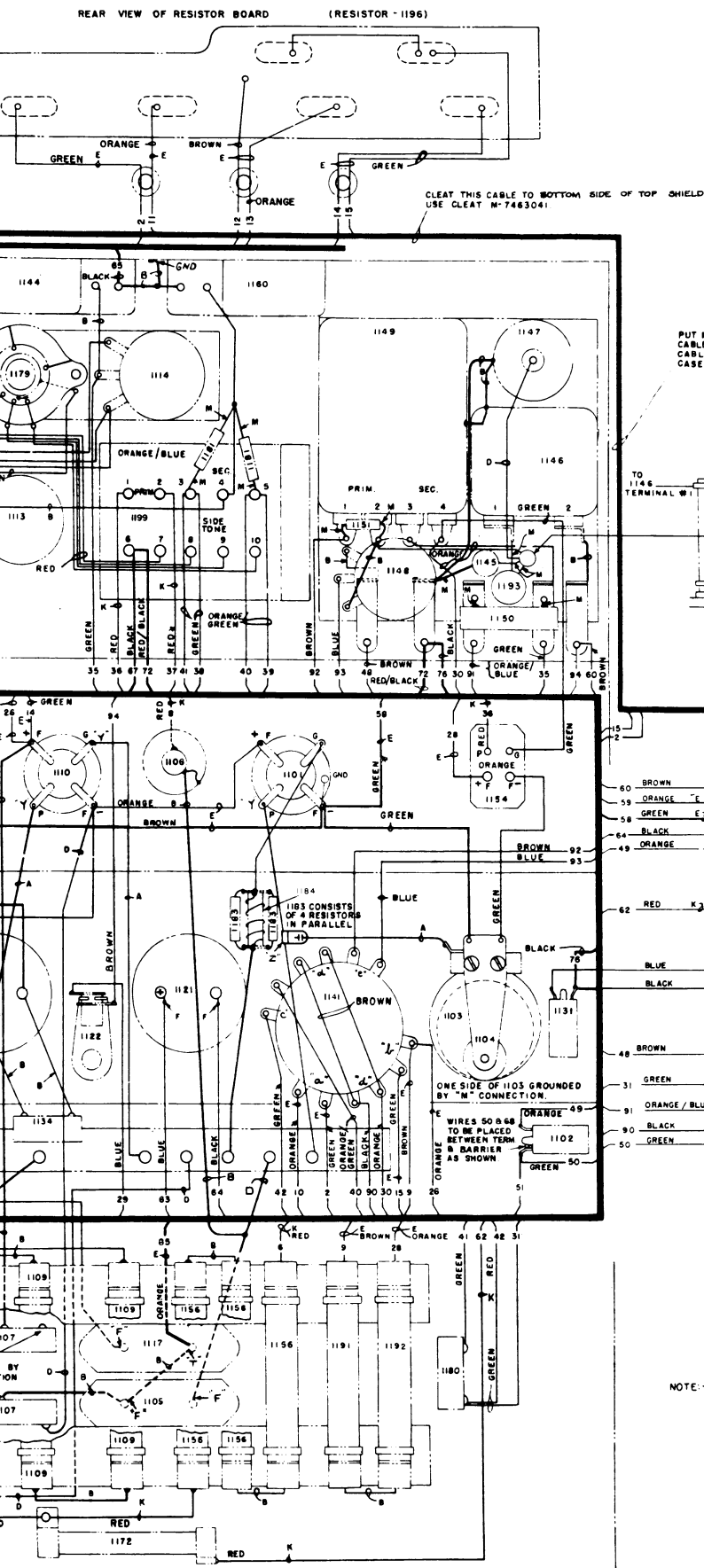

CONNECTION	SIZE OF CONDUCTOR
A	.102" DIA. COPPER WIRE TINNED
B	.061" DIA. COPPER WIRE TINNED
C	.041" DIA. COPPER WIRE TINNED
D	.081" DIA. COPPER WIRE TINNED
E	2 14AWG STRANDS 26/0126 1/32" RUBBER INSULATION G.E. SPECS. K-7872345
UNMARKED COLORED	2 16AWG STRANDS 16/0126 1/64" RUBBER INSULATION G.E. SPECS. K-7872345
M	UNIT PIECE OF APPARATUS
K	2 16AWG 16/0126 STRANDS 3/64" RUBBER INSULATION G.E. SPECS. K-7872345 PT-11.

REFERENCE DRAWING	
SCHEMATIC DIAGRAM	7661804

NOTE: FASTEN WIRES SECURELY TO TERMINALS MECHANICALLY BEFORE SOLDERING. USE ROSIN CORE SOLDER #203C.

THE HEAVY LINES (HIGHWAYS) ARE MERELY GUIDE LINES TO ASSIST IN TRACING CONNECTIONS ON THE DIAGRAM AND DO NOT NECESSARILY INDICATE CABLES. CONDUCTORS SHOULD BE CABLED IN THE MOST CONVENIENT MANNER WHEREVER CABLING IS ADVANTAGEOUS.

AT POINTS MARKED "T" USE TERMINAL K-7884163
 AT POINTS MARKED "F" USE TERMINAL K-7870226
 AT POINTS MARKED "Z" USE TERMINAL K-7872368.

AT POINTS MARKED "W" USE 1/8" X 3/8" COTTER PIN.
 AT POINTS MARKED "Y" USE HOT TIN DIPPED WASHER V-417453

FIGURE 50. RADIO TRANSMITTER BC-375-E, CONNECTION DIAGRAM

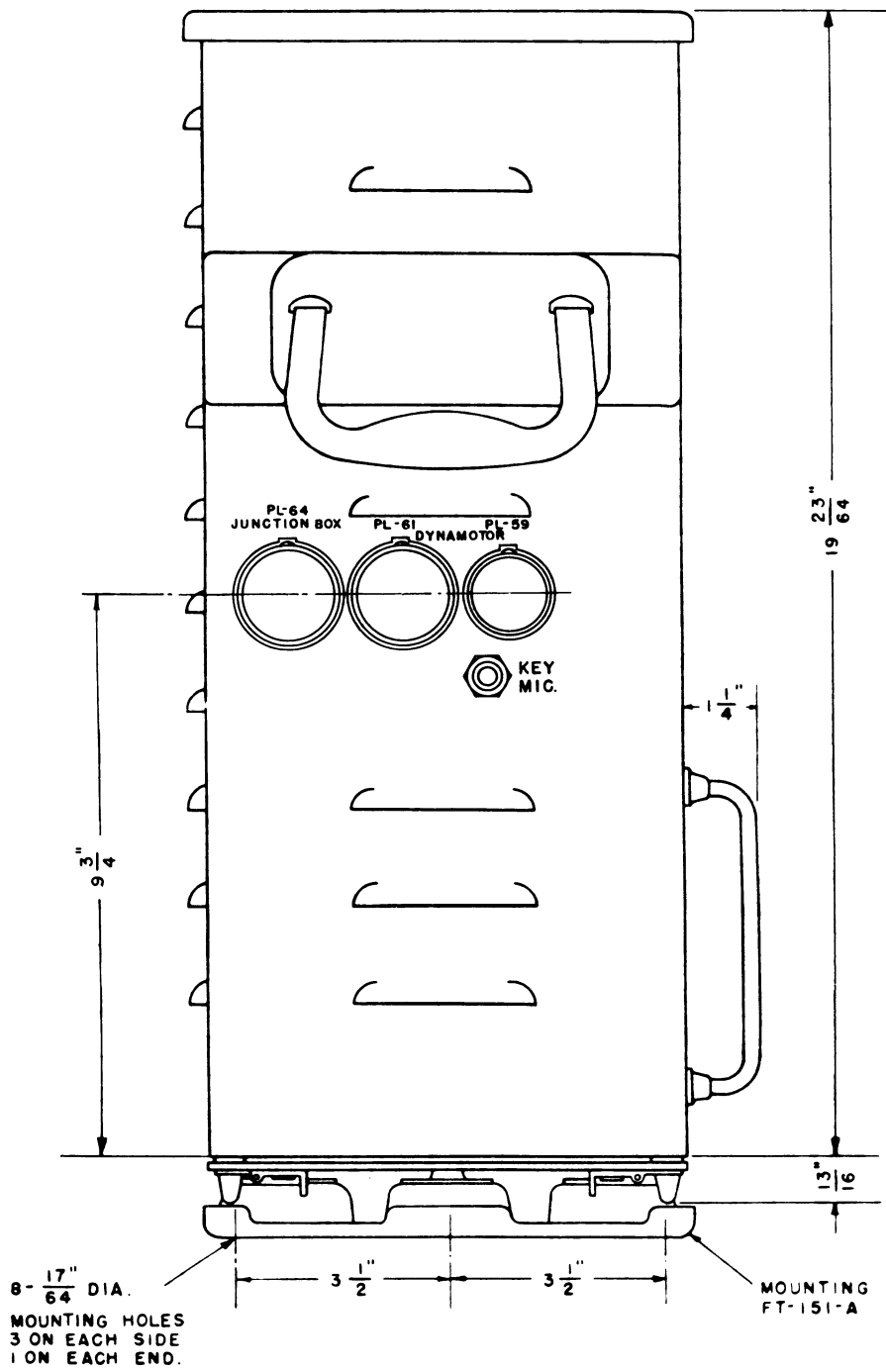

8 - $\frac{17}{64}$ " DIA.
 MOUNTING HOLES
 3 ON EACH SIDE
 1 ON EACH END.

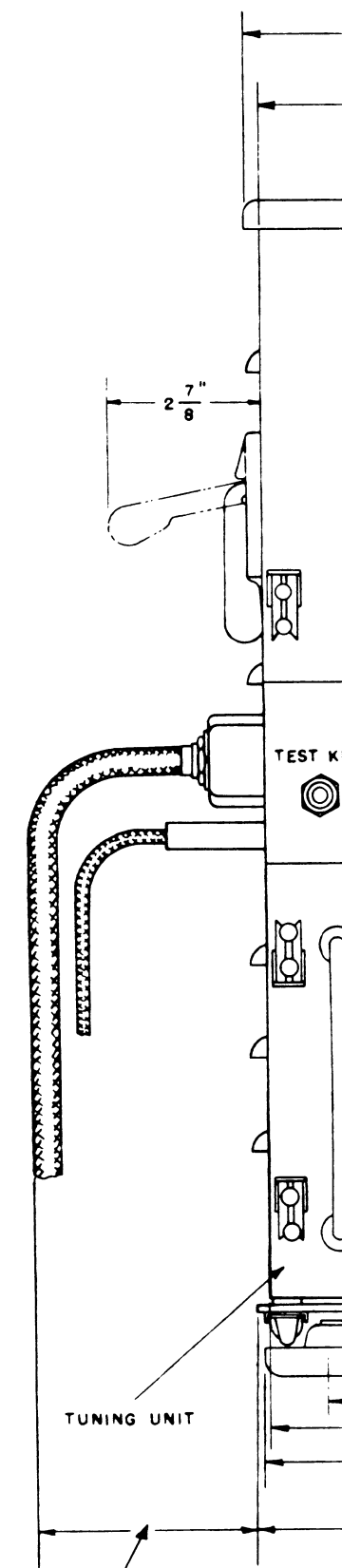

ALLOW 4" TO REMOVE PLUGS
 & OPERATE SNAP-SLIDES

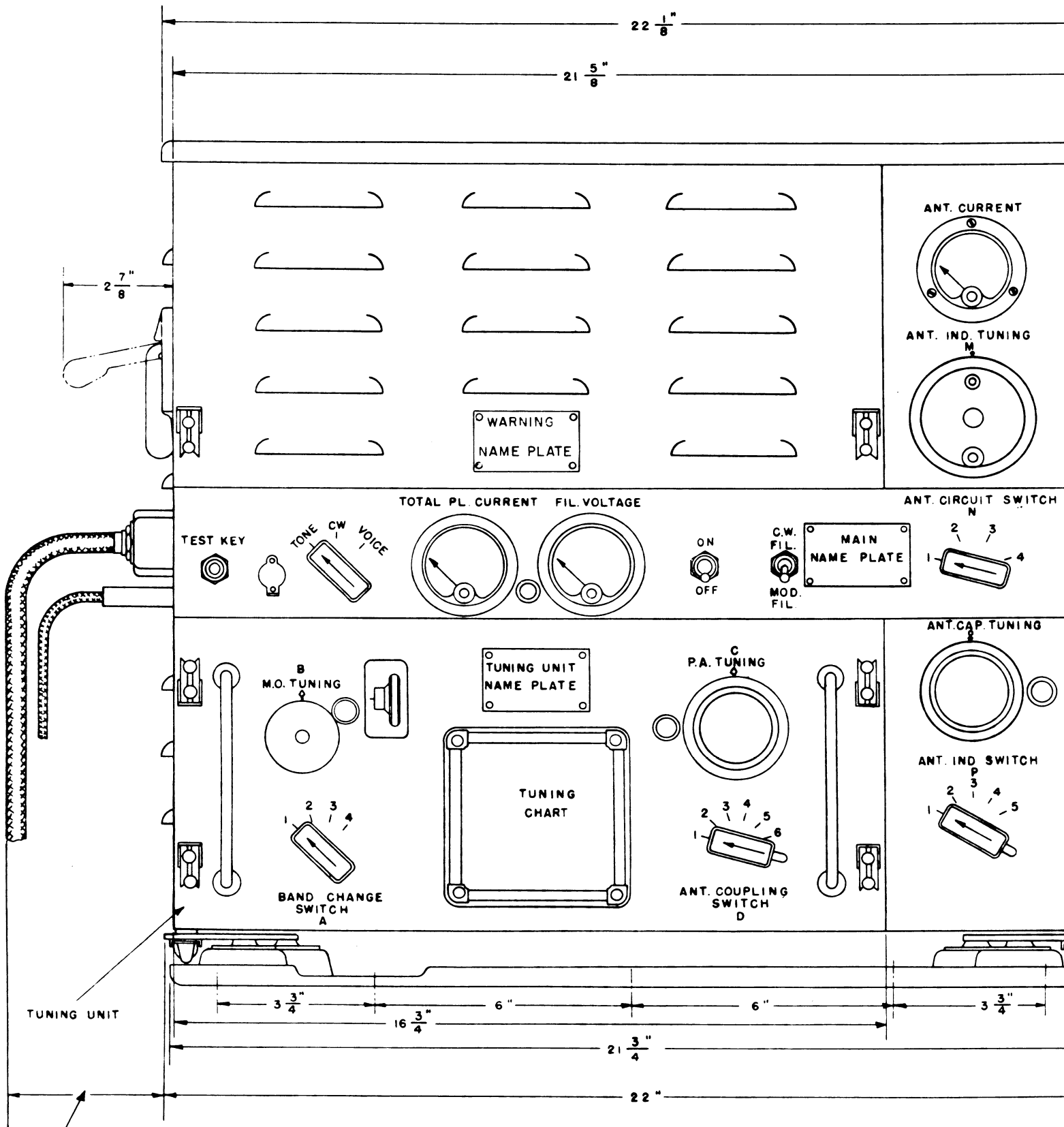

ALLOW 4" TO REMOVE PLUGS
& OPERATE SNAP-SLIDES

WEIGHTS IN POUNDS

Radio Transmitter BC-375-E, without Mounting, Transmitter Tuning Unit, and Tubes	49.0	Transmitter Tuning Unit TU-5-B	... 14.437
Mounting FT-151A	3.75	Transmitter Tuning Unit TU-6-B	... 12.437
One Set of Tubes, Consisting of Four Tubes VT-4-C and One Tube VT-25	2.0	Transmitter Tuning Unit TU-7-B	... 11.687
		Transmitter Tuning Unit TU-8-B	... 11.437
		Transmitter Tuning Unit TU-9-B	... 11.437
		Transmitter Tuning Unit TU-10-B	... 11.437
		Transmitter Tuning Unit TU-26-B	... 12.750

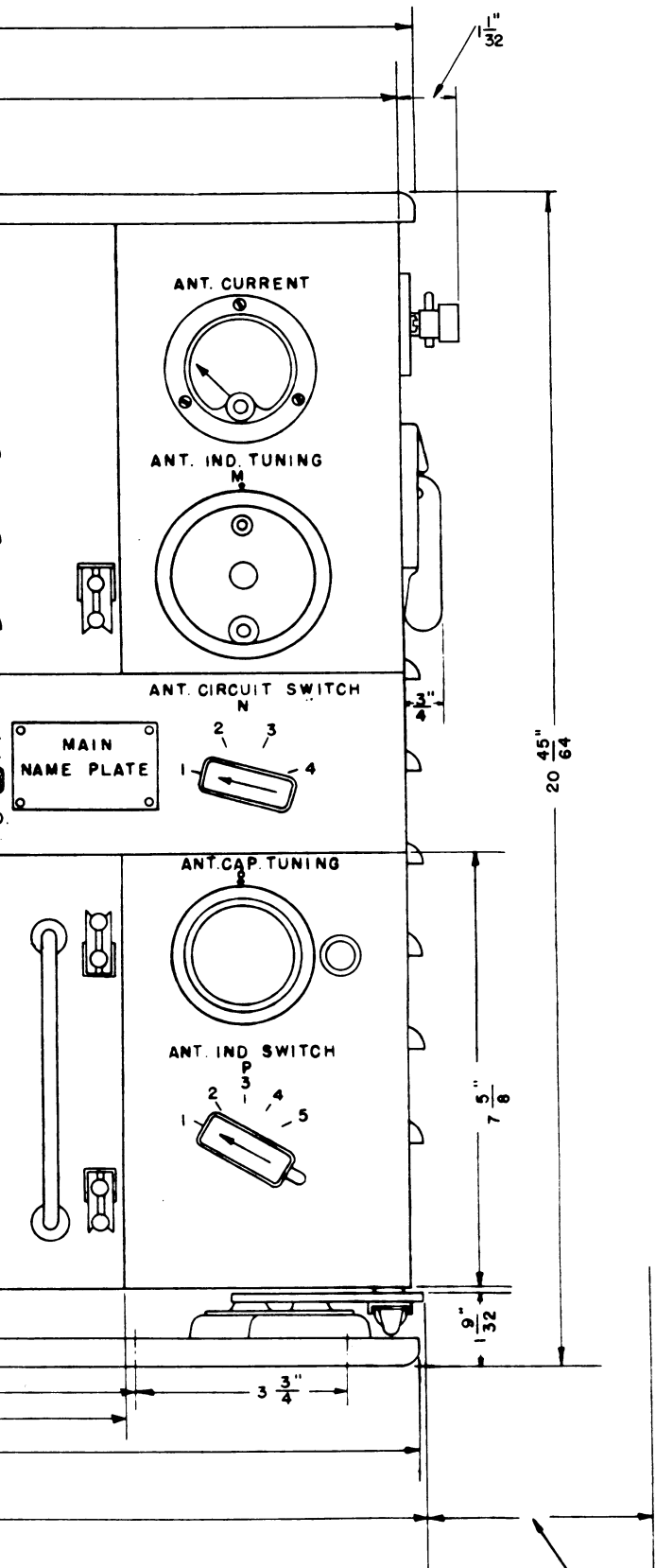

ALLOW 4" TO OPERATE
SNAP-SLIDES

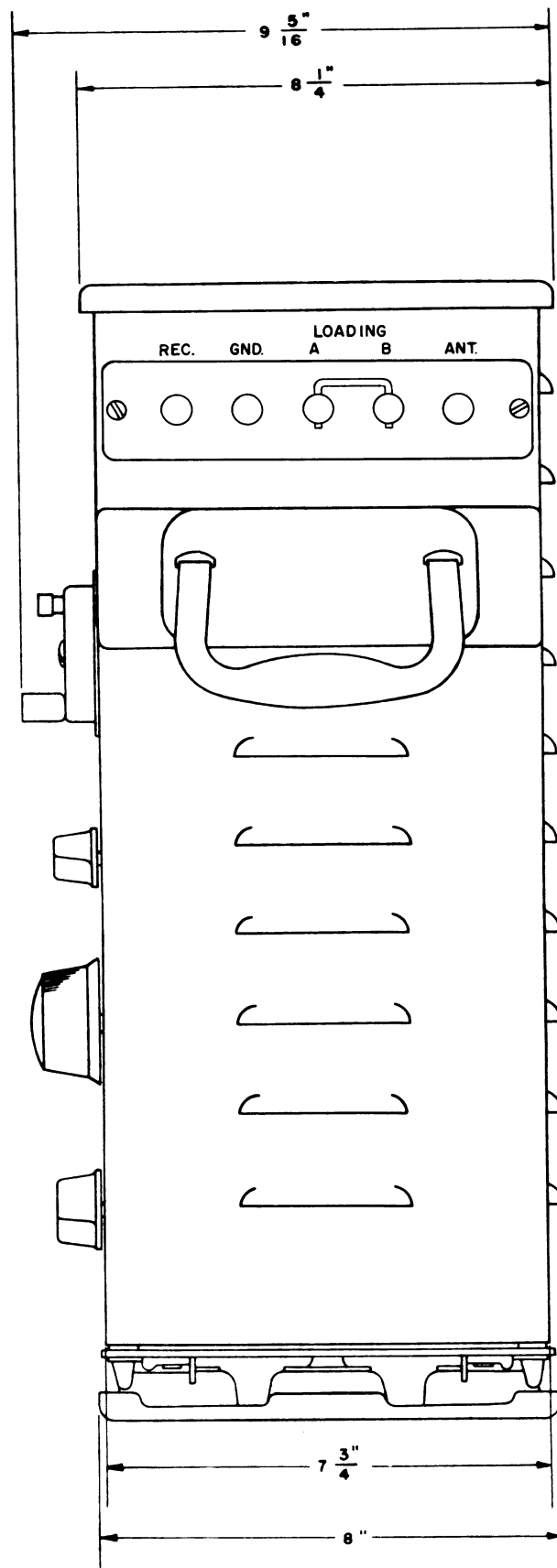

FIGURE 51. RADIO TRANSMITTER BC-375-E,
OUTLINE DIMENSIONAL SKETCH

Tuning Unit TU-5-B	...	14.437
Tuning Unit TU-6-B	...	12.437
Tuning Unit TU-7-B	...	11.687
Tuning Unit TU-8-B	...	11.437
Tuning Unit TU-9-B	...	11.437
Tuning Unit TU-10-B	...	11.437
Tuning Unit TU-26-B	...	12.750

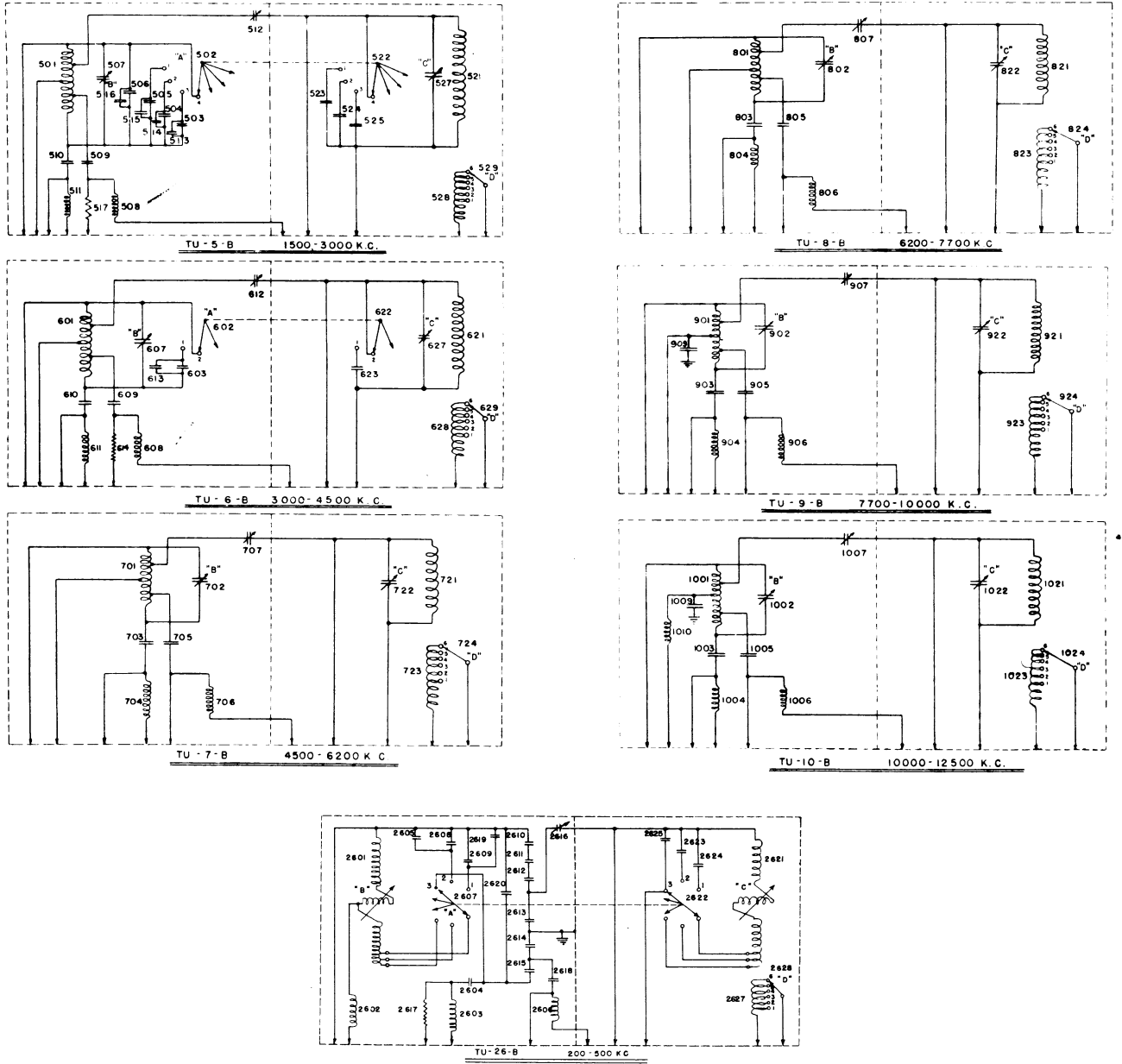

FIGURE 52. TRANSMITTER TUNING UNITS, SCHEMATIC DIAGRAMS

NOTE: THERE SHALL BE NO SHARP POINTS LEFT AFTER UNIT IS WIRED EITHER FROM LUMPS OF SOLDER OR IRREGULARLY CUT WIRE ENDS. WIRE TO BE FASTENED MECHANICALLY TO TERMINALS BEFORE SOLDERING. USE ROSIN CORE SOLDER B2003C

SYMBOL	NAME OF UNIT
601	M.O. TANK INDUCTANCE
602	M.O. BAND CHANGE SWITCH
603	M.O. FIXED TANK CAPACITOR
607	M.O. VARIABLE TANK CAPACITOR
608	P.A. GRID CHOKE
609	P.A. GRID BLOCKING CAPACITOR
610	M.O. GRID BLOCKING CAPACITOR
611	M.O. GRID CHOKE
612	NEUTRALIZING CAPACITOR
613	M.O. COMPENSATING CAPACITOR
614	P.A. GRID PARASITIC RESISTOR
621	P.A. TANK INDUCTANCE
622	P.A. BAND CHANGE SWITCH
623	P.A. FIXED TANK CAPACITOR
627	P.A. VARIABLE TANK CAPACITOR
628	ANTENNA COUPLING COIL
629	ANTENNA COUPLING SWITCH

CONNECTOR	SIZE OF CONNECTOR
W	UNIT PIECE OF APPARATUS
MARKED	1.02 DIA. COPPER WIRE TINNED

NOTE: AT POINTS MARKED "X" USE TERM V-144451
 " " " " "Z" " " K-7872305
 " " " " "Y" " " K-7872831
 " " " " "W" " " K-7872368
 " " " " "S" " " SOLDER COMPLETE JOINT TOGETHER.

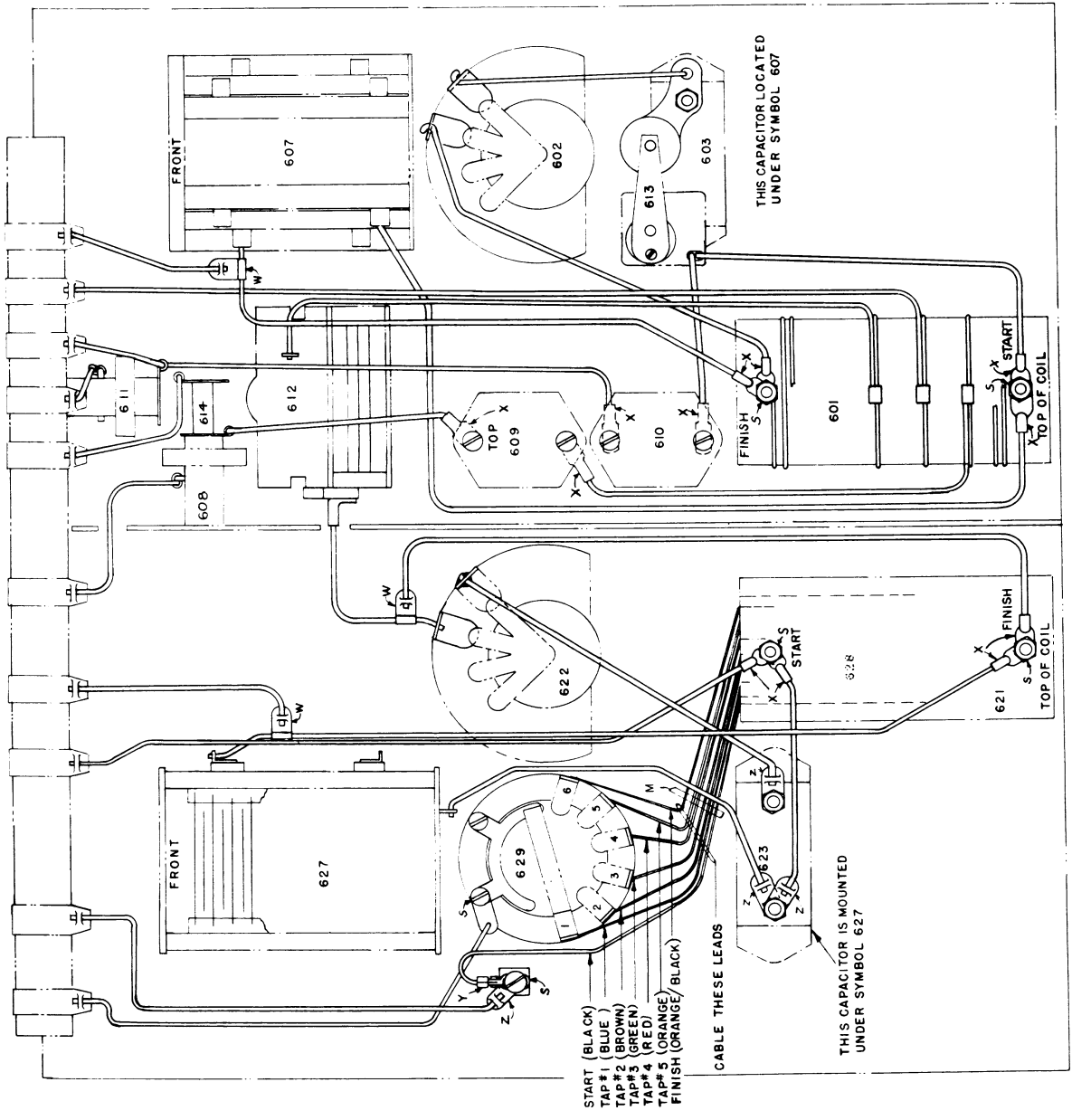

FIGURE 54. TRANSMITTER TUNING UNIT TU-6-B, CONNECTION DIAGRAM

NOTE:
 AT POINTS MARKED "X" USE TERM. V-1444451
 "Z" " " " K-7872305
 "Y" " " " K-7872831
 "W" " " " K-7872368
 "S" " " " SOLDER COMPLETE JOINT TOGETHER.

NOTE:
 THERE SHALL BE NO SHARP POINTS LEFT AFTER UNIT
 IS REWINDED EITHER FROM LUMPS OF SOLDER OR
 FROM WIRE. ALL WIRE SHALL BE MECHANICALLY TO
 WIRE TO BE FASTENED TO TERMINALS. ALL
 TERMINALS BEFORE SOLDERING USE ROSIN
 CORE SOLDER 82003B

SYMBOL	NAME OF UNIT
UNIT'S	
801	MO. TANK INDUCTANCE
802	MO. TANK CAPACITOR
803	MO. GRID BLOCKING CAPACITOR
804	MO. GRID CHOKE
805	P.A. GRID BLOCKING CAPACITOR
806	P.A. GRID CHOKE
807	NEUTRALIZING CAPACITOR
821	P.A. TANK INDUCTANCE
822	P.A. TANK CAPACITOR
823	ANT. COUPLING COIL
824	ANT. COUPLING SWITCH

CONNECTION	SIZE OF CONNECTOR
M	SPECIFIED ON MECHANICAL DRAWING
NOT MARKED	COPPER WIRE TINNED .02 DIA.

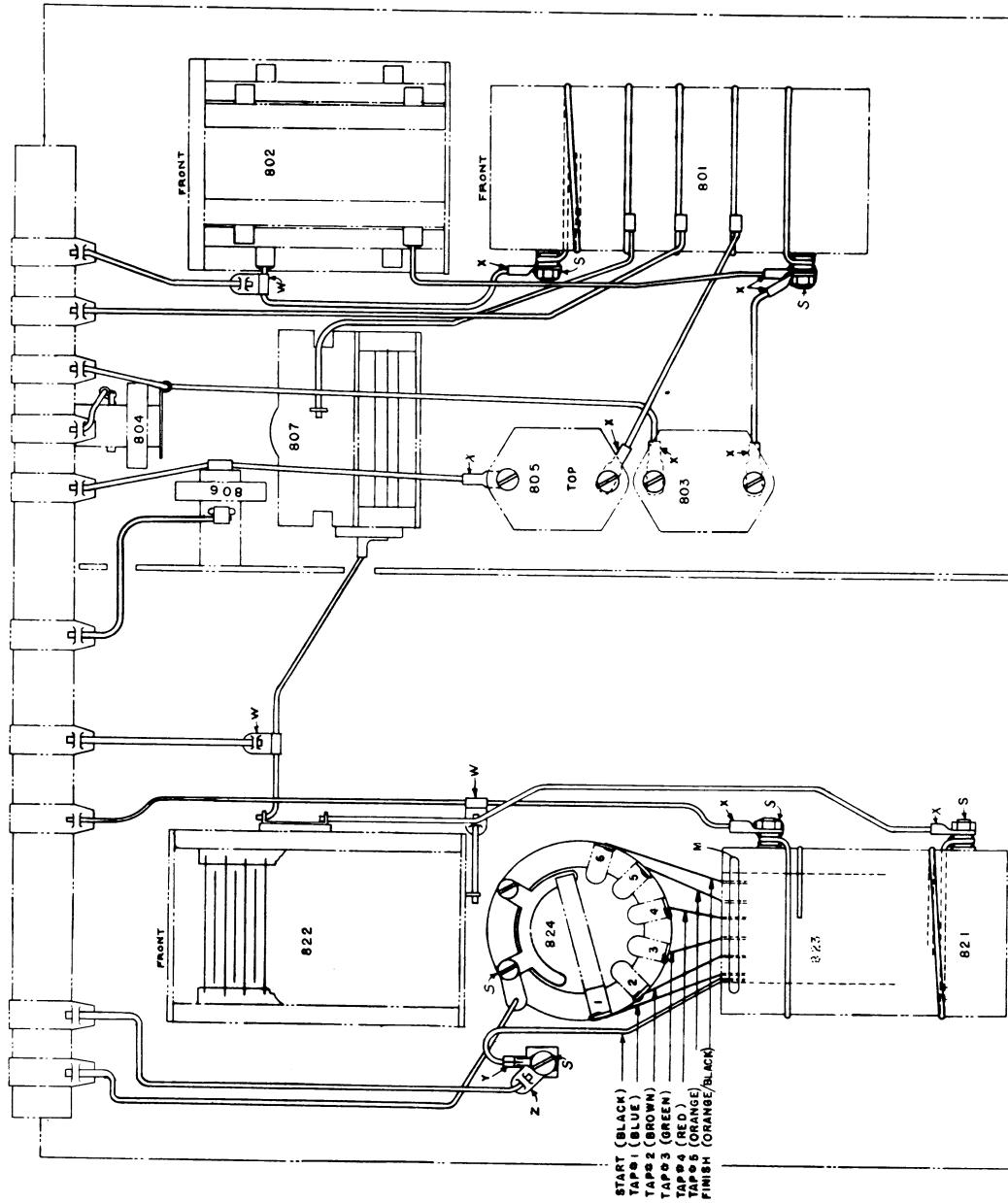

FIGURE 56. TRANSMITTER TUNING UNIT TU-8-B, CONNECTION DIAGRAM

NOTE FOR SOLDERING-
WIRE TO BE FASTENED MECHANICALLY TO TERMINALS
BEFORE SOLDERING. USE ROSIN CORE SOLDER B2603C.
THERE SHALL BE NO SHARP POINTS
LEFT AFTER UNIT IS WIRED EITHER FROM LUMPS OF
SOLDER OR IRREGULAR CUT WIRE ENDS.

SYMBOL	NAME OF PART
2601	M.O. TANK INDUCTANCE
2602	M.O. PLATE CHOKE
2603	M.O. GRID CHOKE
2604	M.O. GRID BLOCKING CAPACITOR
2605	M.O. TANK COMPENSATING CAP.
2606	P.A. GRID CHOKE
2607	M.O. BAND CHANGE SWITCH
2608	M.O. FIXED TANK CAPACITOR
2609	M.O. FIXED TANK CAPACITOR
2610	M.O. CHAIN CAPACITOR
2611	M.O. CHAIN CAPACITOR
2612	M.O. CHAIN CAPACITOR
2613	M.O. CHAIN CAPACITOR
2614	M.O. CHAIN CAPACITOR
2615	M.O. CHAIN CAPACITOR
2616	NEUTRALIZING CAPACITOR
2617	M.O. GRID PARASITIC RESISTOR
2618	P.A. GRID BLOCKING CAPACITOR
2619	M.O. TANK COMPENSATING CAP.
2620	M.O. TANK COMPENSATING CAP.
2621	P.A. TANK INDUCTANCE
2622	P.A. BAND CHANGE SWITCH
2623	P.A. FIXED TANK CAPACITOR
2624	P.A. FIXED TANK CAPACITOR
2625	P.A. FIXED TANK CAPACITOR
2626	ANT. COUPLING COIL
2627	ANT. COUPLING COIL
2628	ANT. COUPLING SWITCH

CONNECTOR	DESCRIPTION
M	UNIT PIECE OF APPARATUS
NOT MARKED	.102" DIA. COPPER WIRE TINNED

NOTE- AT POINTS MARKED "S" SOLDER COMPLETE, JOINT TOGETHER.
AT POINTS MARKED "T" USE TERM. K-7872305.
AT POINTS MARKED "W" USE TERM. K-7872368.
AT POINTS MARKED "X" USE TERM. V-1444451.
AT POINTS MARKED "Z" USE TERM. K-7874007.
AT POINTS MARKED "N" TERMINALS CALLED FOR ON
MECHANICAL DRAWING.
AT POINTS MARKED "Y" USE TERM. K-7872689.

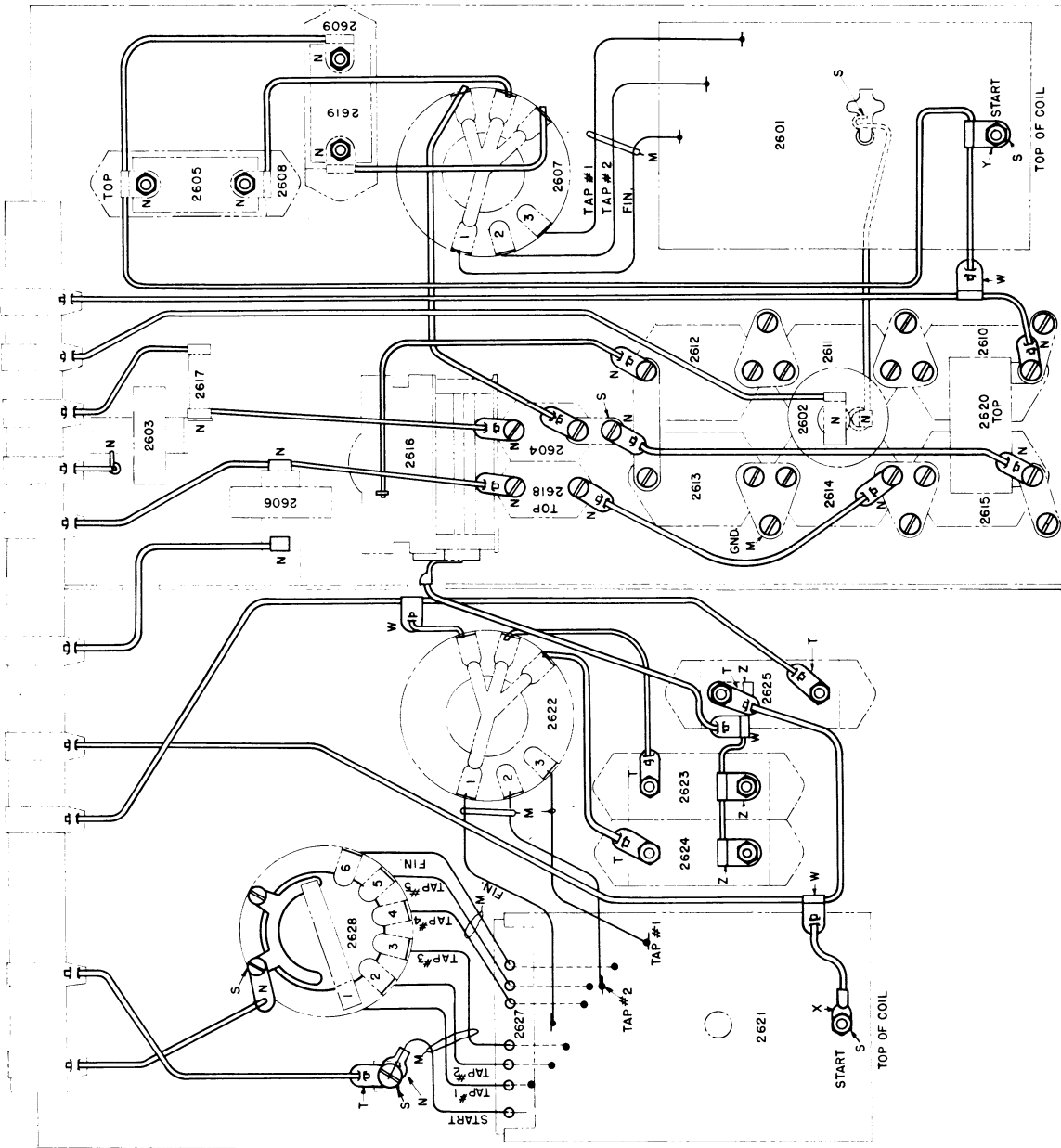

FIGURE 59. TRANSMITTER TUNING UNIT TU-26-B, CONNECTION DIAGRAM

